



## Pipeline Accessories



To  
contents  
click  
here

# 24

# How to navigate through this active PDF file

→ Just click on a product group in the contents to jump directly to that page:



The image shows two overlapping screenshots from a PDF. The top screenshot displays a 'Content' table of contents with a mouse cursor pointing to the 'Casing Spacers System raci 4 pipes' entry. The bottom screenshot shows the product page for 'Casing Spacers 4 pipes - System raci', featuring a 3D model of a spacer ring and a technical data table.

Products	Page
Casing Spacers System raci 4 pipes	5 - 14
Bolted Casing Spacers 4 pipes	15 - 19
Casing Spacers 4 pipes	21 - 22
GFR Fiberoat Ultra Casing Spacers 4 pipes	23 - 24
Casing Endwalls 4 pipes Type AKT/AWM, ADT, ADU, AKG/AKD and ASTM	25 - 31
Heat Shrink Products and Accessories 4 pipes	33 - 37

Technical Data Material HDPE	
Yield strength	> 25 N/mm <sup>2</sup> (test acc. to UNI EN ISO 527-2)
Elongation at break	> 200% (test acc. to UNI EN ISO 527-2)
Hardness shore D	64° - ASTM D 2240
Operating temperature	- 20°C up to + 80°C (for applications below 5°C contact 4 pipes)
Dielectric strength	> 37 kV/mm - ASTM D 1494
UV stabilization	Good

→ Click on the text **"back to contents"** (on each page in lower right corner) to return to contents:

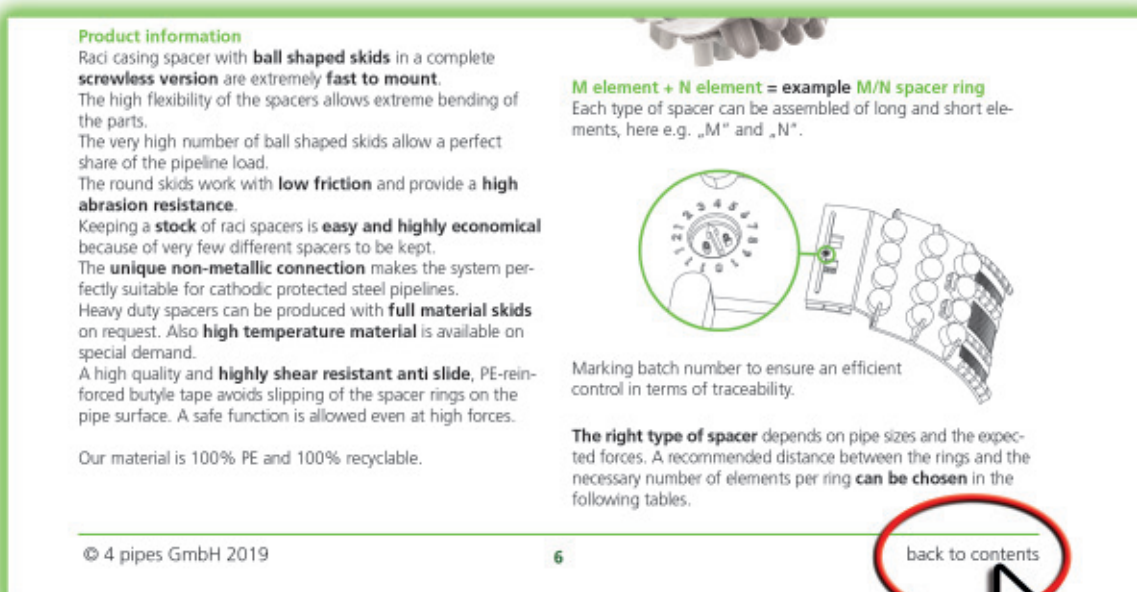

The image shows a product information page for 'Raci casing spacer'. It contains detailed technical text, a diagram of the spacer assembly, and a 'back to contents' button circled in red with a mouse cursor pointing to it.

**Product information**  
Raci casing spacer with **ball shaped skids** in a complete **screwless version** are extremely **fast to mount**. The high flexibility of the spacers allows extreme bending of the parts. The very high number of ball shaped skids allow a perfect share of the pipeline load. The round skids work with **low friction** and provide a **high abrasion resistance**. Keeping a **stock** of raci spacers is **easy and highly economical** because of very few different spacers to be kept. The **unique non-metallic connection** makes the system perfectly suitable for cathodic protected steel pipelines. Heavy duty spacers can be produced with **full material skids** on request. Also **high temperature material** is available on special demand. A high quality and **highly shear resistant anti slide**, PE-reinforced butyle tape avoids slipping of the spacer rings on the pipe surface. A safe function is allowed even at high forces.

Our material is 100% PE and 100% recyclable.

**M element + N element = example M/N spacer ring**  
Each type of spacer can be assembled of long and short elements, here e.g. „M“ and „N“.















Marking batch number to ensure an efficient control in terms of traceability.

**The right type of spacer** depends on pipe sizes and the expected forces. A recommended distance between the rings and the necessary number of elements per ring **can be chosen** in the following tables.

© 4 pipes GmbH 2019 6



Products		Page
	<b>Casing Spacers 4 pipes</b> System raci - screwless	6 - 16
	<b>Bolted Casing Spacers 4 pipes</b>	17 - 21
	<b>GRP Pipecoat Plus</b> Casing Spacers 4 pipes	22 - 24
	<b>Casing Endseals 4 pipes</b> Type AKT/AWM, AST, ADU, AKG/AKO and ASTM	25 - 32
	<b>Heat Shrink Products and Accessories 4 pipes</b>	33 - 39
	<b>Corrosion Protection Tapes 4 pipes</b>	40 - 51
	Mechanical Pipeline Protection 4 pipes: Fibercoat Ultra / Rock Shield Fleece / Pipecoat Plus	52 - 57
	<b>Pressio®-Rings</b> Wall Penetration Seals 4 pipes	58 - 79
	<b>Pressio®-Rings BlackLine</b> Wall Penetration Seals 4 pipes	66 - 67
	Pressio® Wall Penetration Seals 4 pipes - Pressio® <b>Individual</b> and potable water	68 - 69
	Wall Penetration Seals Pressio® 4 cables® <b>Wall Penetration Sets 4 pipes</b>	80 - 90 91 - 92
	<b>District Heating Baseplate Penetration 4 pipes</b>	93 - 96
	Pressio® Wall Penetration Seals and Wall Sleeves with Fixed-Loose Flange 4 pipes	97 - 103
	<b>Pressio®-Elements</b> Wall Penetration Seals 4 pipes	104 - 115
	Rubber Support Rings and Conical Sealing Plugs 4 pipes	116 - 119
	<b>Manhole Connectors</b> Type P-MC 4 pipes	120 - 121
	<b>Aqua Stopper</b> Pipeline Closure Plugs 4 pipes	122 - 124

Products		Page
	Sealing Sleeves Type <b>Compenseal®</b> and Type KMR <b>4 pipes</b>	125 - 129
	Wall Collars <b>4 pipes</b> Labyrinth Wall Penetration Seals <b>4 pipes</b>	130 - 134 135 - 136
	Pipe Bushings <b>4 pipes</b>	137 - 138
	<b>Wall Sleeves</b> Fibre Cement <b>4 pipes</b>	139 - 141
	<b>Wall Sleeves</b> / Shaft Linings <b>PVC 4 pipes</b>	142 - 144
	<b>Wall Sleeves Steel</b> , Epoxy Coating Resin <b>4 pipes</b>	145 - 147
	<b>Rubber Steel Gasket</b> Type RSG, RSG-TW-K and RSG for ANSI Flanges <b>4 pipes</b> <b>Rubber Gasket</b> flexible Type RFG <b>4 pipes</b>	148 - 153
	<b>Rubber Steel Gasket</b> adjustable Type RSG-TW-V <b>4 pipes</b>	150 - 151
	Combi-Seal <b>Flange Isolation Gaskets</b> Type G and TW <b>4 pipes</b>	154 - 159
	<b>Flange Bolt Isolation Kits 4 pipes</b>	160 - 161
	<b>Fittings 4 pipes</b>	162 - 164
	<b>Cleaning Pigs 4 pipes</b>	165 - 168
	<b>Tools 4 pipes</b> – Pipe Chamfering Tool, Cleaning Strap, Uni-Key Adaptor, Shore D Measuring Tool	169 - 173
	<b>Magnetic Cover Lifters and Accessories 4 pipes</b>	174 - 177
	<b>Pipe Storage 4 pipes</b>	178 - 184
	Conversion of pressure units	185
	Terms of sale	186

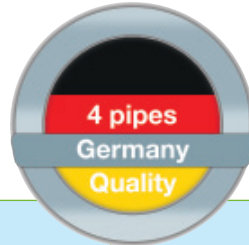

**QUACERT**  
**CERTIFICATE**  
DIN EN ISO 9001:2015



4 pipes GmbH  
Sigmundstraße 182  
90431 Nürnberg

has established and applies in the field of

**development, distribution and logistics  
of pipeline accessories**

a system complying with the requirements of the  
above-mentioned standard. Proof of this has been furnished  
during a system audit on 01 and 02 September 2021.

First certification: 2015  
Period of validity: 2021-09-15 - 2024-09-14  
Registration number: QC-QM-Z-05/012-001

Schwäbisch Gmünd, 15 September 2021

QUACERT  
Gesellschaft zur Zertifizierung von  
Qualitätsmanagement-Systemen mbH  
Erlanger Straße 137  
D-73379 Schwäbisch Gmünd  
Tel: +49 - 71 71 - 99 79 16 80  
Fax: +49 - 71 71 - 99 79 16 99  
www.quacert.de

*Plaus*  
Management

This document is valid solely for the sector not regulated by law and has no annex.  
The certificate remains the property of QUACERT to whom it must be returned on request.

**QUACERT**  
**CERTIFICATE**  
DIN EN ISO 14001:2021



4 pipes GmbH  
Sigmundstraße 182  
90431 Nürnberg

has established in the field of

**development, distribution and logistics  
of pipeline accessories**

a system complying with the requirements of the  
above-mentioned standard. Proof of this has been furnished  
during a system audit on 01 and 02 September 2021.

First certification: 2015  
Period of validity: 2021-09-15 - 2024-09-14  
Registration number: QC-UM-Z-15/012-001

Schwäbisch Gmünd, 15 September 2021

QUACERT  
Gesellschaft zur Zertifizierung von  
Qualitätsmanagement-Systemen mbH  
Erlanger Straße 137  
D-73379 Schwäbisch Gmünd  
Tel: +49 - 71 71 - 99 79 16 80  
Fax: +49 - 71 71 - 99 79 16 99  
www.quacert.de

*Plaus*  
Management

This document is valid solely for the sector not regulated by law and has no annex.  
The certificate remains the property of QUACERT to whom it must be returned on request.

**4 pipes GmbH**  
Sigmundstr. 182  
D-90431 Nuremberg / Germany  
Phone +49 (0)911 81006-0  
Fax +49 (0)911 81006-111  
info@4pipes.de  
[www.4pipes.de](http://www.4pipes.de)



Pipeline Accessories

## Casing Spacers 4 pipes System raci







## Technical Data Material HDPE

Yield strength	≥ 25 N/mm <sup>2</sup> (test acc. to UNI EN ISO 527-2)
Elongation at break	> 200% (test acc. to UNI EN ISO 527-2)
Hardness shore D	64° - ASTM D 2240
Operating temperature	- 20°C up to + 40°C
Dielectric strength	> 37 kV/mm - ASTM D 149/64
UV stabilization	Good

Raci spacer elements fit together easily and can be fastened using a standard pipe wrench or a special tightening tool for the heavier types. No time-consuming screwing of element to element has to be done on site.

The tooth connection system allows a quick and safe mounting on the carrier pipe.

Only seven basic types of spacers provide complete coverage for all pipes from 38 to 2500 mm.

This completely metal-free system provides extremely high mechanical load capacity.

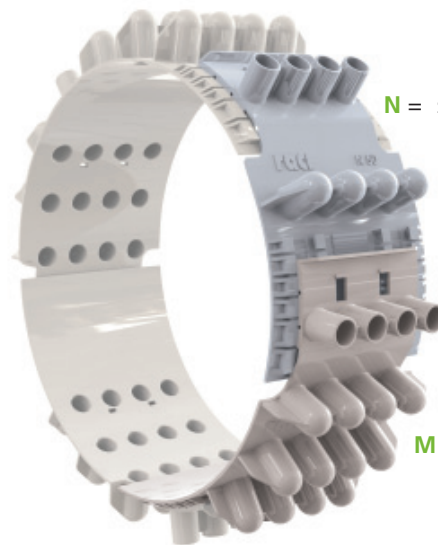

N = short element

M = long element

## Product information

Raci casing spacers, with **ball shaped skids** in a completely **screwless version**, are extremely **fast to mount**.

The high flexibility of the spacers allows extreme bending of the parts.

The very high number of ball-shaped skids ensures that the pipeline load is perfectly distributed.

The round skids work with **low friction** and provide a **high abrasion resistance**.

Keeping a **stock** of raci spacers is **easy and highly economical** because very few different spacers need to be kept.

The **unique non-metallic connection** makes the system perfectly suitable for cathodic protected steel pipelines.

Heavy duty spacers can be produced with **full material skids** on request. High-temperature material is also available for special requirements.

A highly shear-resistant, anti-slide butyl tape prevents the spacer rings from slipping on the pipe surface. This high-quality tape is reinforced with PE, facilitating safe functioning, even when high forces are exerted.

Our material is 100% PE and 100% recyclable.

## M element + N element = example M/N spacer ring

Each type of spacer can be assembled from long and short elements, here e.g. „M“ and „N“.

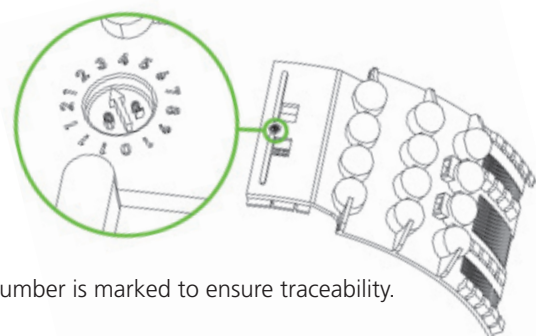

Batch number is marked to ensure traceability.

**The right type of spacer** depends on pipe sizes and the expected forces. A recommended distance between the rings and the necessary number of elements per ring can be determined using the following tables.



# Casing Spacers 4 pipes - System raci

## Select the right spacer

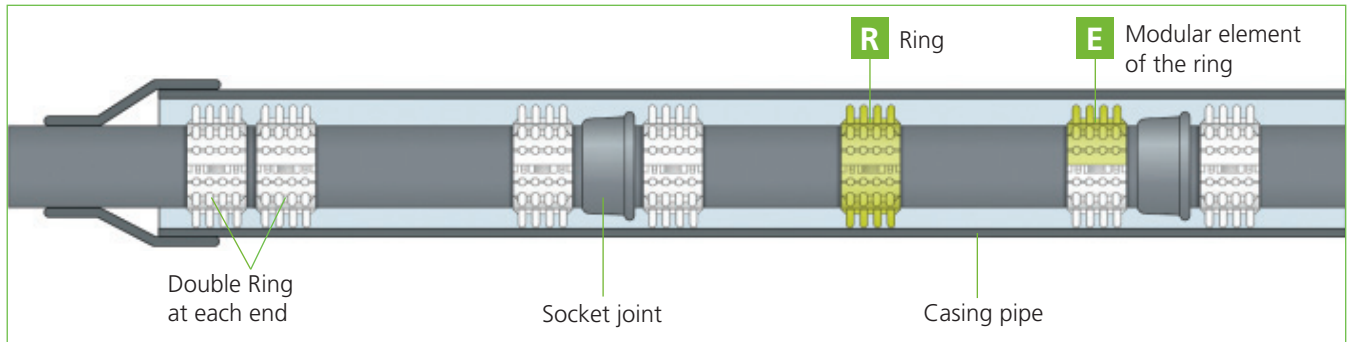

1. Choose possible types of spacers
2. When there are various choices, select the spacer according to the expected load. In case of doubt, choose the more stable type.
3. Select skid height:
  - OD : Outside diameter carrier pipe
  - ID : Inside diameter casing pipes
  - O.Db : Outside diameter bell

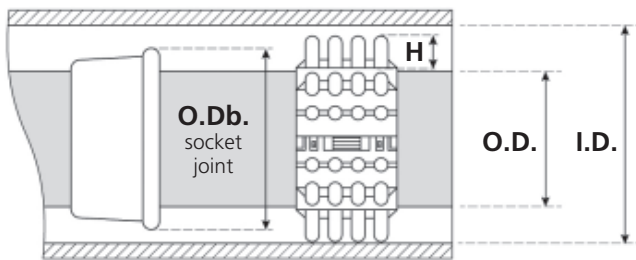

Consider a clearance of height min. 12-15 mm when selecting the maximum skid height.

Skids should be min. 15 mm higher than the OD of a bell.

Number of spacers =  
Length of the crossing/recommended distance +3



Rollers for spacers system raci

# Casing Spacers 4 pipes - System raci



**A/B Type spacers**  
 Max. load capacity  
 180 kg/ring  
 Available skid heights:  
 19, 36 and 50 mm  
 Length of elements usable:  
 Type A = 105-122 mm  
 Type B = 87-103 mm  
 Width 100 mm

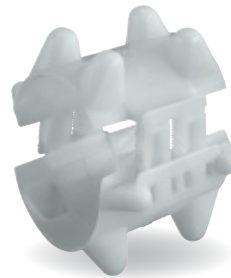

**S/T Type spacers**  
 Max. load capacity  
 110 kg/ring  
 Available skid height 19 mm  
 Length of elements usable:  
 Type S = 92-109 mm  
 Type T = 117-132 mm  
 Width 85 mm

No special tool necessary!

No special tool necessary!

OD pipe in mm		No. of elements per ring		max. distance recommended
min.	max.	A	B	
55.4	65.6*	-	2	1.5 m
61.3	71.5*	1	1	1.5 m
67.3	77.4*	2	-	1.5 m
82.9	94.4	-	3	1.5 m
89.1	104.3	1	2	1.5 m
101.1	116	3	-	1.5 m
110.8	131.2	-	4	1.5 m
116.6	137.1	1	3	1.5 m
134.7	154.8	4	-	1.5 m
150.3	175.8	2	3	1.5 m
168.5	193.5	5	-	1.5 m
193.5	229.6**	-	7	1.0 m
202.2	232.2**	6	-	1.0 m
230	254**	6	1	1.0 m
255	279**	7	1	1.0 m
280	309.6**	8	-	1.0 m

\*S/T spacers are preferred for these sizes  
 \*\*M/N spacers are recommended for these sizes

OD pipe in mm		No. of elements per ring		max. distance recommended
min.	max.	S	T	
59	68	2	-	1.5 m
69	75	1	1	1.5 m
76	84	-	2	1.5 m
88	102	3	-	1.5 m
103	107	2	1	1.5 m
108	114	1	2	1.5 m
115	120	-	3	1.5 m
121	132	4	-	1.5 m
133	140	3	1	1.5 m
141	146	2	2	1.5 m
147	152	1	3	1.5 m
153	168	-	4	1.5 m

## A Type spacers

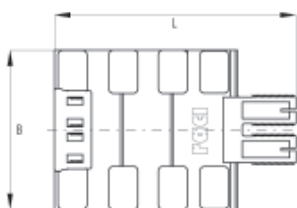

## B Type spacers

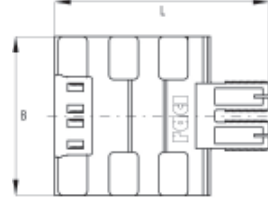
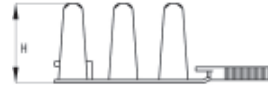

## S Type spacers

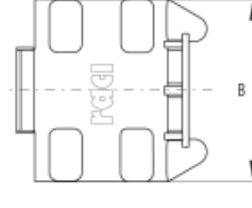
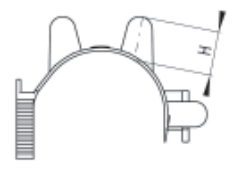

## T Type spacers

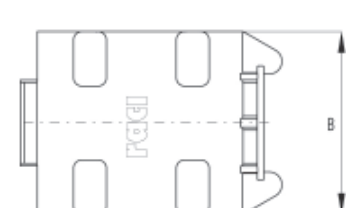

Type	Length		Width (B)		Height (H)		max. load kg
	mm	inch	mm	inch	mm	inch	
A	113-128	4.5-5	100	3.9	19	0.75	180
					36	1.42	
B	95-110	3.7-4.3	100	3.9	50	1.97	

Type	Length		Width (B)		Height (H)		max. load kg
	mm	inch	mm	inch	mm	inch	
S	94-110	3.7-4.3	85	3.3	19	0.8	110
T	119-135	4.6-5.3	85	3.3	19	0.8	

Max. load has been calculated for a static state. If there are dynamic forces, these need to be considered in addition.

Max. load has been calculated for a static state. If there are dynamic forces, these need to be considered in addition.

# Casing Spacers 4 pipes - System raci

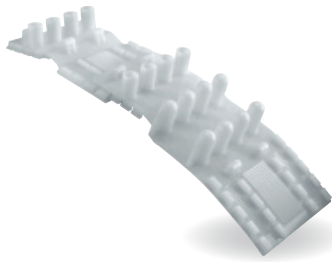

## F/G Type spacers

Max. load capacity 500 kg/ring  
 Available skid heights:  
 25, 41 and 60 mm  
 Length of elements usable:  
 Type F = 198-228 mm  
 Type G = 95-121 mm  
 Width 130 mm

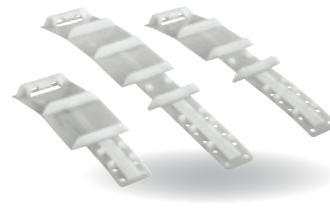

## ICD Type spacers

Max. load capacity 200 kg/ring  
 Available skid height 15 mm  
 Length of elements usable:  
 Type I = 130-160 mm  
 Type C = 180-250 mm  
 Type D = 240-310 mm  
 Width 63 mm

Use tightening clamp Type F/G, M/N, L or lever

No special tool necessary!

OD pipe in mm		No. of elements per ring		max. distance recommended
min.	max.	F	G	
116*	145*	2	-	2 m
124*	150*	1	2	2 m
154	182	2	1	2 m
189	217	3	-	2 m
219	256	3	1	1.5 m
254	282	4	-	1.5 m
283	315	4	1	1.5 m
316	345	5	-	1.5 m

\*S/T or A/B spacers are recommended for these pipe sizes

OD pipe in mm		No. of elements per ring			max. distance recommended
min.	max.	I	C	D	
42	52	1	-	-	1 m
58	79	-	1	-	1 m
80	93	-	-	1	1 m
94	100	2	-	-	1 m
101	120	1	1	-	1 m
121	145	-	2	-	1 m
146	165	-	1	1	1 m
166	197	-	-	2	1 m

## F Type spacers

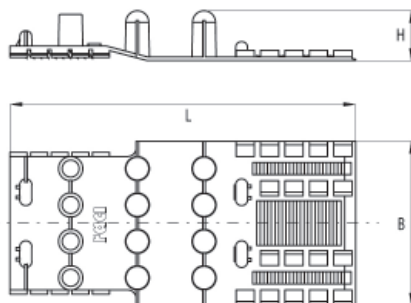

## G Type spacers

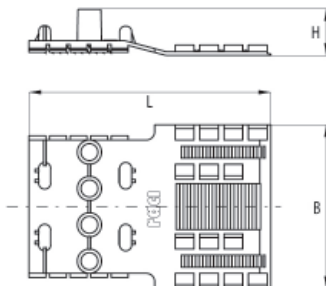

## I Type spacers

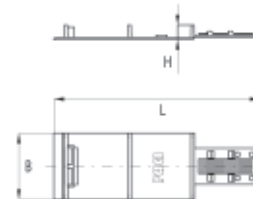

## C Type spacers



## D Type spacers



Type	Length		Width (B)		Height (H)		max. load kg
	mm	inch	mm	inch	mm	inch	
F	197-237	7.7-9.3	130	5.1	25, 41 60	0.98 - 1.61 2.36	500
G	91-129	3.6-5	130	5.1	25, 41 60	0.98 - 1.61 2.36	500

Max. load has been calculated for a static state. If there are dynamic forces, these need to be considered in addition.

Type	Length		Width (B)		Height (H)		max. load kg
	mm	inch	mm	inch	mm	inch	
I	130-160	5-6.3	63	2.5	15	0.6	200
C	180-250	7-9.8	63	2.5	15	0.6	200
D	240-310	9.4-12	63	2.5	15	0.6	200

Max. load has been calculated for a static state. If there are dynamic forces, these need to be considered in addition.

# Casing Spacers 4 pipes - System raci

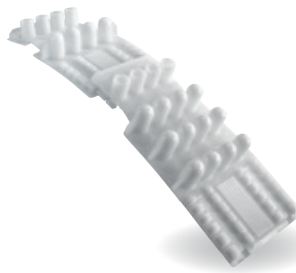

## M/N Type spacers

Max. load capacity  
1.000 kg/ring  
Available skid heights:  
18, 36, 50, 75 and 90 mm  
Length of elements usable:  
Type M = 265-320 mm  
Type N = 185-240 mm  
Width 180 mm



## E/H Type spacers

Max. load capacity  
2.700 kg/ring  
Available skid heights:  
25, 41, 60, 90, 110, 130 mm  
Length of elements usable:  
Type E = 280-320 mm  
Type H = 130-170 mm  
Width 225 mm

Use tightening clamp Type F/G, M/N, L

OD pipe in mm		No. of elements per ring		max. distance recommended
min.	max.	M	N	
160*	201	2	-	2 m
202	227	1	2	2 m
228	252	2	1	2 m
253	286	3	-	2 m
287	311	2	2	2 m
312	337	3	1	2 m
338	395	4	-	2 m
396	421	4	1	2 m
422	505	5	-	2 m
506	590	6	-	1.5 m
591	674	7	-	1.5 m
675	759	8	-	1.5 m

\*F/G spacers are recommended for these pipe sizes

Use tightening clamp Type E/H

OD pipe in mm		No. of elements per ring		max. distance recommended
min.	max.	E	H	
306*	354	3	1	2 m
355	397	4	-	2 m
398	457	4	1	2 m
458	489	5	-	2 m
490	549	5	1	2 m
550	580	6	-	2 m
581	641	6	1	2 m
642	732	7	-	2 m
733	800	8	-	1.8 m
801	900	9	-	1.8 m
901	1000	10	-	1.8 m
1001	1099	11	-	1.8 m
1100	1191	12	-	1.8 m
1192	1283	13	-	1.5 m
1284	1374	14	-	1.5 m
1375	1466	15	-	1.2 m
1467	1558	16	-	1.2 m
1559	1650	17	-	1.2 m
1651	1741	18	-	1 m
1742	1833	19	-	1 m
1834	1925	20	-	0.8 m
1926	2108	21	-	0.7 m
2109	2200	23	-	0.7 m
2201	2292	24	-	0.7 m

## M Type spacers

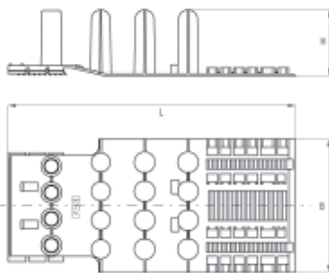

## N Type spacers

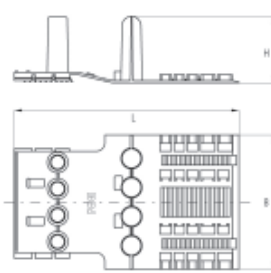

Type	Length		Width (B)		Height (H)		max. load kg
	mm	inch	mm	inch	mm	inch	
M	265-320	10.4-12.6	180	7.1	18, 36, 50, 75,	0.7 - 1.42	1000
N	185-240	7.3-9.4	180	7.1	90	1.97 - 2.95	

Max. load has been calculated for a static state. If there are dynamic forces, these need to be considered in addition.

**Attention: For spacers with skids above 125 mm, the max. load capacity reduces to 50% of the given value. NEVER forget anti sliding tape.**

## E Type spacers

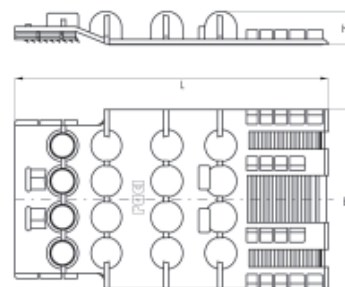

## H Type spacers

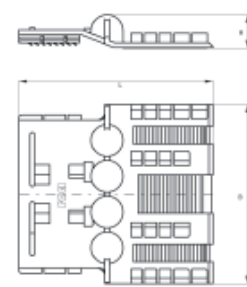

Type	Length		Width (B)		Height (H)		max. load kg
	mm	inch	mm	inch	mm	inch	
E	280-335	11 - 13.2	225	8.8	25, 41, 60	0.98 - 1.61	2700
					90	3.54	
H	130-185	5.1-7.3	225	8.8	110, 130	4.33 - 5.12	

Max. load has been calculated for a static state. If there are dynamic forces, these need to be considered in addition.



# Casing Spacers 4 pipes - System raci

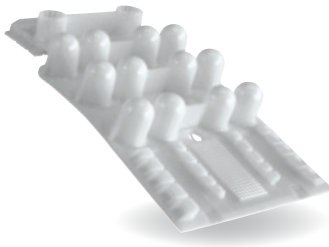

## L Type spacers

Available skid heights:  
25, 50, 75, 100, 125, 150,  
175 and 200 mm  
Length of element usable:  
Type L = 280-325 mm  
Width 210 mm

Use tightening clamp Type F/G M/N, L

OD pipe in mm min.	OD pipe in mm max.	No. of elements per ring	max. distance recommended	
			Water	Gas
355	397	4	2.5 m	2.5 m
450	510	5	2.5 m	2.5 m
540	610	6	2.5 m	2.5 m
625	715	7	2.5 m	2.5 m
715	805	8	2.5 m	2.5 m
805	895	9	2 m	2.5 m
895	985	10	2 m	2.5 m
985	1075	11	1.5 m	2.5 m
1075	1160	12	1 m	2 m
1160	1250	13	1 m	2 m
1250	1340	14	1 m	2 m
1340	1430	15	0.8 m	2 m
1430	1520	16	0.8 m	2 m
1520	1610	17	0.5 m	2 m
1610	1750	18	0.5 m	2 m

## L Type spacers

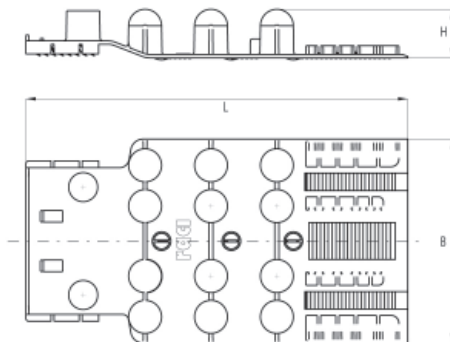

Type	Length		Width (B)		Height (H)		max. load kg
	mm	inch	mm	inch	mm	inch	
L25 L50	280- 325	11- 12.8	210	8.3	25, 50	0.98 1.97	3000
L75 L100					75, 100	2.95 3.94	
L125					125	4.92	2000
L150 L175 L200					150, 175, 200	5.91 6.89 7.87	1500

Max. load has been calculated for a static state. If there are dynamic forces, these need to be considered in addition.

## Special Applications

You need to bring **several pipes** through one casing!  
We calculate the **bundle** for you or find a **customized solution**.



## Example bundling

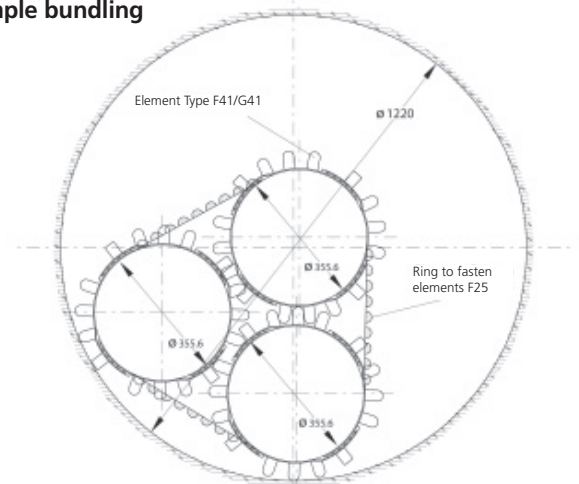

## Example cable casing pipes

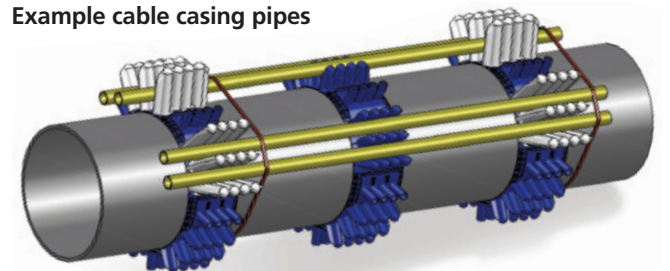



# Spacers System raci 4 pipes with Integrated High-performance Plastic Rollers



### E41 Roller Type spacers

Max. load capacity: 2000 kg  
Available skid height: 41 mm  
Length of elements usable:  
280-320 mm  
Width 225 mm



### Product Information

These plastic spacer rings are a combination of the tried and trusted spacers in the series E/H with additional **rollers made from glass-fibre-reinforced high-performance plastic (PA 30)**. The roller elements have a ball shape that ensures a **particularly high load capacity**. The combination of materials and the stability of the roller axles mean that **frictional force is reduced** by up to 54% **during feedthrough**, in comparison to a feedthrough without rollers. As this product does not contain any metallic connecting pieces, it is absolutely suitable for deployment with cathodically-protected steel pipeline constructions.

### Advantages:

- Rollers pre-installed by supplier
- Frictional force reduced by up to 54% during feedthrough
- Low roller height means they are suitable for use in tight spaces
- **Completely metal-free design**
- Fast and easy installation
- Our modular system ensures that this product is fully compatible with existing spacers and tools



Use tightening clamp Type E/H

OD pipe in mm from to		No. of elements per ring E41 roller H41*		max. distance recommended
355	397	4	–	2 m
398	457	4	1	2 m
458	489	5	–	2 m
490	549	5	1	2 m
550	580	6	–	2 m
581	641	6	1	2 m
642	732	7	–	2 m
733	800	8	–	1.8 m
801	900	9	–	1.8 m
901	1000	10	–	1.8 m
1001	1099	11	–	1.8 m
1100	1191	12	–	1.8 m
1192	1283	13	–	1.5 m
1284	1374	14	–	1.5 m
1375	1466	15	–	1.2 m
1467	1558	16	–	1.2 m
1559	1650	17	–	1.2 m
1651	1741	18	–	1 m
1742	1833	19	–	1 m
1834	1925	20	–	0.8 m
1926	2108	21	–	0.7 m
2109	2200	23	–	0.7 m
2201	2292	24	–	0.7 m

\*Type H41 is a connecting piece with only one row of skids without rollers



Demonstration Video

Installation as with system raci  
without rollers

## Rollers for Spacers 4 pipes - System raci

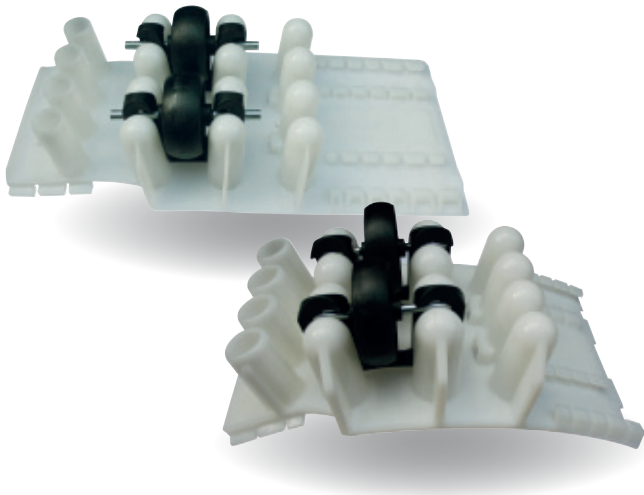

### Rollers for Spacers M75 and E90

- One or two rollers per element usable
- 300 kg max. load per roller
- Roller M max. height 85 mm
- Roller E max height 110 mm
- Reduces friction more than 50%
- Roller made from fibre-reinforced polyamide
- Wheel axle made from galvanised steel
- Easy plug-in mounting

Item	Skid height	Article No.
<b>Roller for casing spacer M/75</b> Max. load 300 kg/Roller at vertical load	height 85 mm overall	17086
<b>Roller for casing spacer E/90</b> Max. load 300 kg/Roller at vertical load	height 110 mm overall	17085



Plug rollers into the flat spacer before fastening onto pipe



# Casing Spacers 4 pipes - System raci

## Application instructions:

Before mounting please choose the right spacer and the right **number of elements** per ring for your application. A double ring of spacers is mounted at the end and the beginning of the crossing.

1. For preparation, pre-fix the right number of elements per ring by inserting two or three teeth. **DO NOT CLOSE THE RING.** Decide the spacers' position on the carrier pipe. Apply **anti slide tape** under each ring to avoid movement of the rings on the pipe surface.
2. To mount on the pipe, connect ends of the ring by inserting two or three teeth deep.
3. Tighten all element connections evenly until the ring is fixed on the pipe properly. Do not fasten the elements unequally.
4. The minimum **overlap of the connection zones is 50%**, better 2/3. If the spacers are applied one or more days before insertion, the rings **MUST be tightened again**.

## NO Special clamp for type A/B, S/T and I/C/D



Assembly with F/G tightening lever

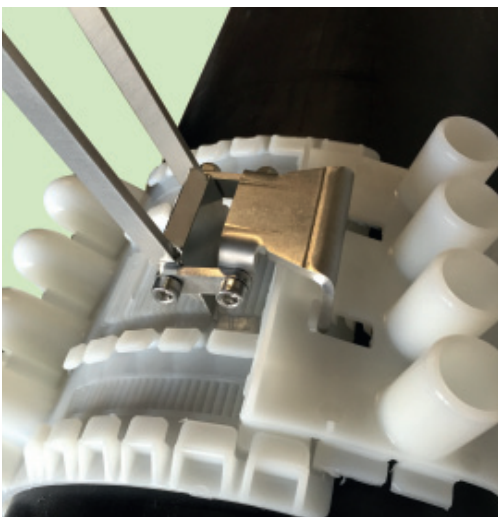

Installation video

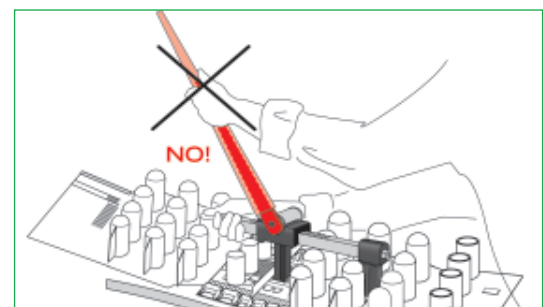
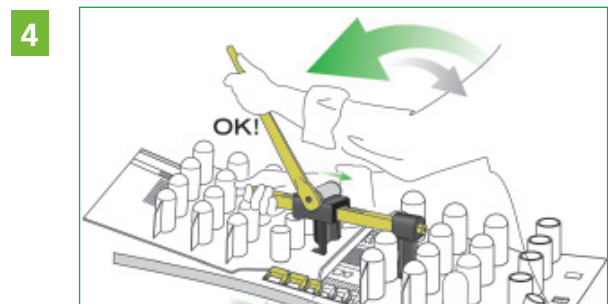
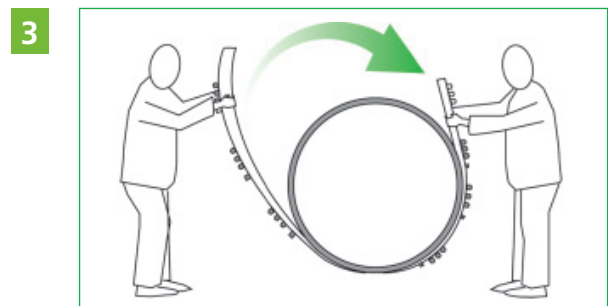
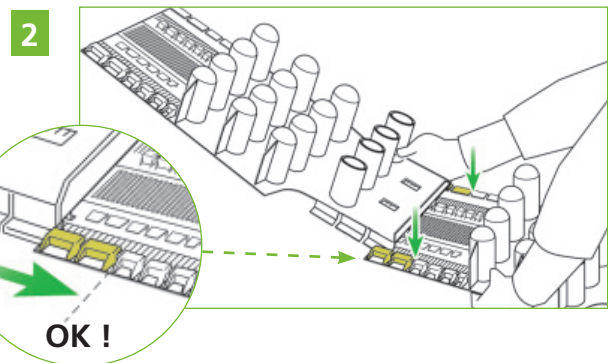
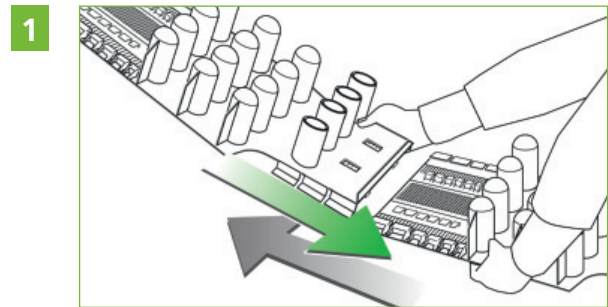

Never use an extended lever.



# Casing Spacers 4 pipes - System raci

## Fastening clamps at 4 pipes

- Screwless and easy fixing tool
- High quality steel lever
- Long lever allows easy application
- Hardened main steel bar
- Usable in both directions
- Left and right hand use possible
- Supplied in high quality tool box



Fastening clamp

Type	Art.-No.
Fastening clamp for Type M/N, F/G and L Skid height max. 90 mm	17070
Fastening clamp for Type M/N and L Skid height max. 200 mm	17077
Fastening clamp for Type E/H	17072



## Tightening lever for F/G spacers



- Long lever for easy application
- Designed for F/G spacers
- Cost effective tool for pipes up to 12" (DN300), especially for a few rings only
- Made of stainless steel

Type	Art.-No.
F/G tightening lever	17076

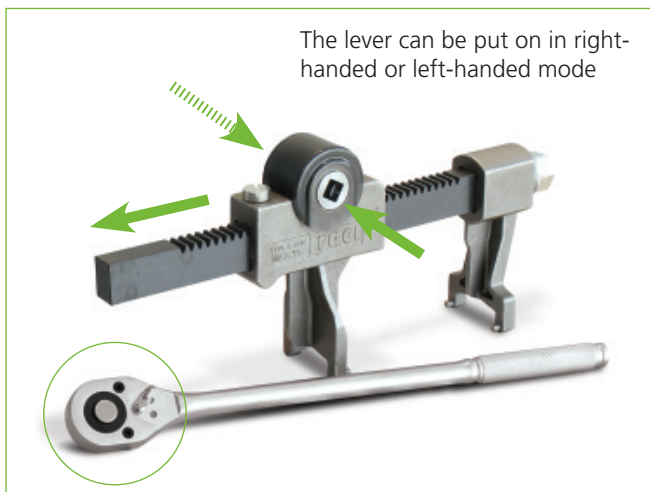

Fastening clamps can be rented from 4 pipes.



Installation video  
Tightening lever



Pipeline Accessories

## Bolted Casing Spacers 4 pipes

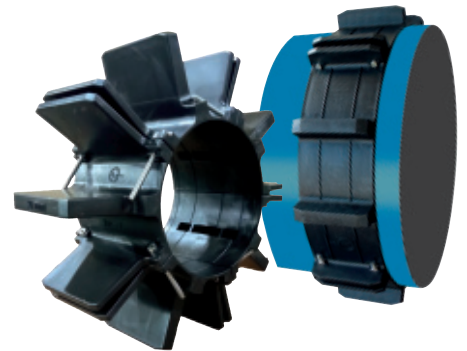



# Casing Spacer 4 pipes - Type KAS for pipeline cased crossings

KAS-1 short element



KAS-2 standard element

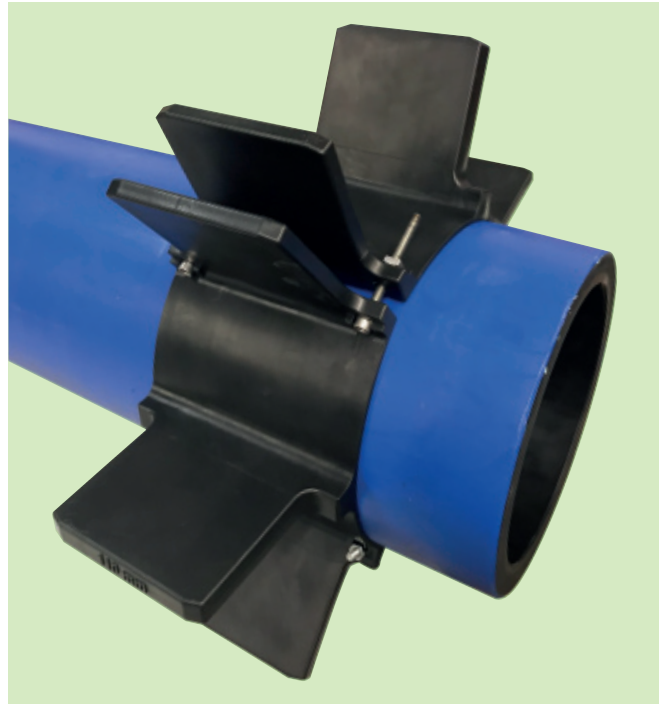

- Perfect for pipe OD 98 - 380 mm
- Casing spacer with bolted connection
- **Innovative skid design**
- **Bolts outside of the skids, easy to mount**
- Fast assembly by easy bolt connection
- Bolts – stainless steel with inner hex head
- High durability
- UV stabilized
- Material polypropylene black
- Square nuts for optimized mounting
- **Available skid heights: 20, 36, 50, 75, 90, 110 mm**
- Width 150 mm
- Electrical strength > 10 kV/mm
- Operating temperature -10°C up to +50°C

OD carrier pipe in mm		Number of elements		Bolts	max. distance recommended
min.	max.	KAS-1	KAS-2	Number/Size	
98	130	3		6 M6 x 70	2
130	172	4		8 M6 x 70	2
173	210	5		10 M6 x 70	2
211	228		3	6 M6 x 70	2
229	260	1	3	8 M6 x 70	2
261	300		4	8 M6 x 70	1,5
301	345	1	4	10 M6 x 70	1,5
346	380		5	10 M6 x 70	1,5

Maximum static load	kg / ring
Skid height 25, 36 und 50 mm	750
Skid height 75, 90 und 100 mm	500

Maximum loads are under static conditions. Dynamic forces need to be considered individually.

The 4 pipes warranty for KMS casing spacers only applies to faulty material. Checking the suitability of the product for the individual application is solely the responsibility of the user.

# Casing Spacer 4 pipes - Type KAS

## Assembly instructions

Before joining the elements choose the number of elements and bolts acc. to our selection tables.

1. In the first step join the elements with the attached bolts. Do not close the ring at this stage. Put nuts only on the end of the bolts.  
4 pipes anti-slide tape provides best possible hold of rings on smooth pipe surfaces like PE, PP, PVC, steel or ductile iron.

2. For assembly, put the ring around the pipe and connect the last bolts. Now tighten all bolts evenly. Make sure there is an even gap between the elements when finished.
3. When tightening (**max. 8 Nm**) the square nuts should sit in the cavity of the spacer. Depending on the pipe dimension, it may not be necessary to close the gaps completely.

### 1. Anti-slide tape



### 2. Connect elements with bolts



### 3. Apply ring

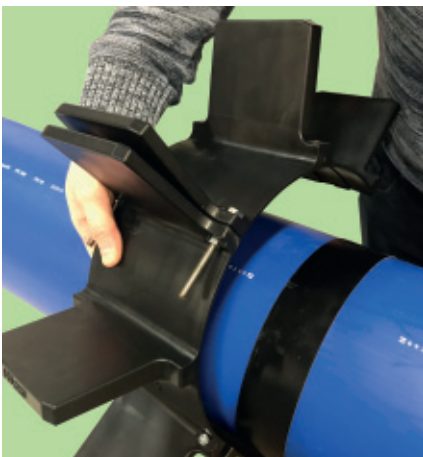

### 4. Tighten bolts evenly

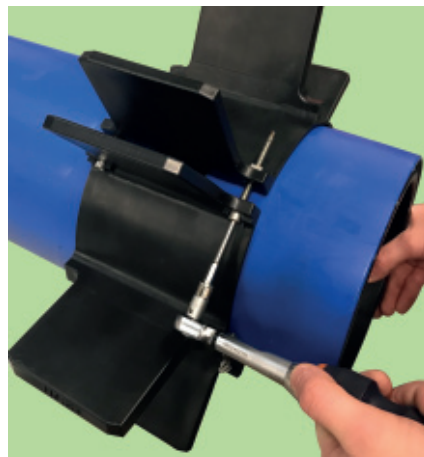

### Fully assembled ring

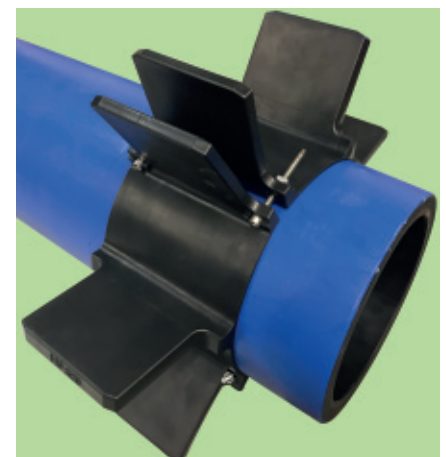

# Casing Spacer 4 pipes - Type KMS for pipeline cased crossings

## Type KMS-1 standard element



## Type KMS-1.5 extra long element



- Perfect for pipe OD 400 - 1200 mm
- Spacers with bolted connections
- Innovative skid design
- Less elements per ring due to **extra long KMS 1.5 version**
- Fast assembly due to less elements
- Material **polypropylene** black
- High durability
- UV stabilized
- Bolts – stainless steel with inner hex head
- Square nuts for optimized mounting
- **Available skid heights 25, 36, 50, 75, 100 and 125 mm**
- Width 160 mm
- Electrical strength > 10 kV/mm
- Operating temperature -10°C up to +50°C

Maximum static load	kg / ring
Skid height 25, 36, 50 und 75 mm	2000
Skid height 100 und 125 mm	1000

Maximum loads are under static conditions. Dynamic forces need to be considered individually.



Pipe size		OD carrier pipe in mm		Number of elements		Bolts	max. distance recommended
DN	Inch	min.	max.	KMS-1	KMS-1.5	Number/Size	
400	16	400	430	4		8 M8 x 70	2
450	18	450	480	3	1	8 M8 x 70	2
500	20	500	538	5		10 M8 x 70	2
550	22	550	585	4	1	10 M8 x 70	2
600	24	600	628		4	8 M8 x 70	2
		629	649	6		12 M8 x 70	2
650	26	650	680	2	3	10 M8 x 70	2
		680	699	5	1	12 M8 x 70	2
700	28	700	732	1	4	10 M8 x 70	2
		732	750	7		14 M8 x 70	2
750	30	751	780		5	10 M8 x 70	2
		780	799	6	1	14 M8 x 70	2
800	32	800	835	2	4	12 M8 x 70	2
		835	850	8		16 M8 x 70	1.8
850	34	851	880	1	5	12 M8 x 70	1.8
		880	900	7	1	16 M8 x 70	1.8
900	36	901	951		6	12 M8 x 70	1.8
950	38	952	1000	2	5	14 M8 x 70	1.8
1000	40	1001	1050	1	6	14 M8 x 70	1.5
1050	42	1051	1100		7	14 M8 x 70	1.5
1100	44	1101	1150	2	6	16 M8 x 70	1.5
1150	46	1151	1200	1	7	16 M8 x 70	1.5
1200	48	1201	1249		8	16 M8 x 70	1.5

The 4 pipes warranty for KMS casing spacers only applies to faulty material. Checking the suitability of the product for the individual application is solely the responsibility of the user.



# Casing Spacer 4 pipes - Type KMS

## Assembly instructions

Before joining the elements choose the number of elements and bolts acc. to our selection tables.

1. In the first step join the elements with the attached bolts. Do not close the ring at this stage. Put nuts only on the end of the bolts.  
4 pipes anti-slide tape provides best possible hold of rings on smooth pipe surfaces like PE, PP, PVC, steel or ductile iron.

2. For assembly, put the ring around the pipe and connect the last bolts. Now tighten all bolts evenly. Make sure there is an even gap between the elements when finished.
3. When tightening (**max. 8 Nm**) the square nuts should sit in the cavity of the spacer. Depending on the pipe dimension, it may not be necessary to close the gaps completely.

### 1. Preassembly acc. to selection table



### 2. Anti-slide tape

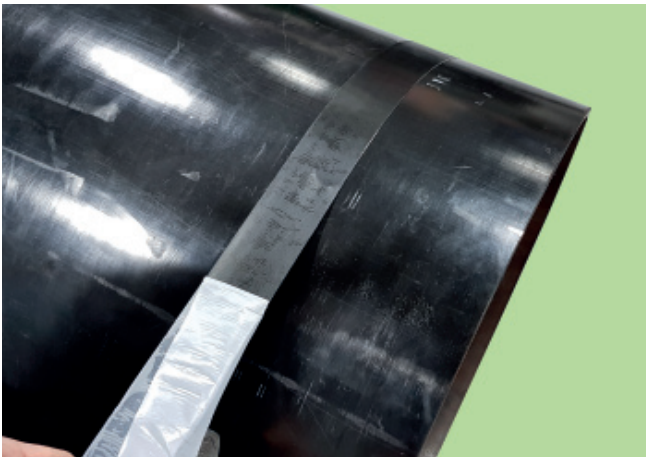

### 3. Apply ring



### 4. Connect bolts



### 5. Tighten bolts evenly



### Fully assembled ring





Pipeline Accessories

## GRP Pipecoat Plus Casing Spacers 4 pipes





# GRP Pipecoat Plus Casing Spacers 4 pipes



## GRP Pipecoat Plus Casing Spacer 4 pipes

For annular spaces that are too small for the skid heights or usage of standard plastic casing spacers, or in case of an extreme rough and abrasive inner surface of the casing pipe, a casing spacer wrapped on the pipe using Pipecoat Plus tape material is the ideal, safe and easy solution.

A factory pre-impregnated, water-curing tape with a thickness of approx. 0.7 mm per layer can be wrapped on the carrier pipe and easily cured with water.

An "anti-slide" tape made of self-amalgamating, PE-reinforced butyl prevents sliding of the GRP ring during insertion and can be used to further increase the height of the GRP ring. After application of the PE/butyl-tape and the GRP tape on top, the system is overwrapped with a clear foil tightly and centred to press the system on the pipe and smoothen the edges. Available widths are 100 and 150 mm as standard.

Technical Data (typical numbers)		
Thickness	-	approx. 0,7 mm
Compressive strength	DIN EN ISO 604	approx. 175 N/mm <sup>2</sup>
Color	-	black
Impact strength	DIN EN ISO 179	approx. 108 N/mm <sup>2</sup>
Impact toughness	DIN EN ISO 179	approx. 30 KJ/m <sup>2</sup>
Max. shortterm service temperature	-	max. 150°C
Hardeness Shore D	DIN 53505	approx. 70°



Shore D measuring tool

**ATTENTION:**  
Always adhere to all applicable health and safety regulations.

Consumption table*					
Skid height approx. [mm]	6	8	10	12	14
<b>OD Pipe</b>					
25	0.44	0.44	0.44	0.44	0.44
	0.34	0.55	0.95	1.3	1.7
32	0.55	0.55	0.55	0.55	0.55
	0.43	0.75	1.1	1.6	2
40	0.68	0.68	0.68	0.68	0.68
	0.53	0.95	1.4	1.9	2.5
50	0.83	0.83	0.83	0.83	0.83
	0.66	1.1	1.7	2.3	3
63	1	1	1	1	1
	0.82	1.4	2.1	2.8	3.6
75	1.2	1.2	1.2	1.2	1.2
	0.97	1.7	2.5	3.3	4.2
90	1.4	1.4	1.4	1.4	1.4
	1.16	2	3	3.9	5
100	1.6	1.6	1.6	1.6	1.6
	1.3	2.2	3.3	4.4	5.5
110	1.7	1.7	1.7	1.7	1.7
	1.4	2.5	3.6	4.8	6

approx.required length anti sliding tape (5 layers) per skid [m]

approx.required length Pipecoat Plus per skid [m]

\*For other dimensions please contact 4 pipes

Description	Art.-No.
Roll anti sliding tape 50 mm x 15 Meter	17080
Roll anti sliding tape 100 mm x 15 Meter	17081
Roll Pipecoat Plus 100 mm x 10 Meter	16711
Roll Pipecoat Plus 150 mm x 10 Meter	16712
Adhesive tape transparent 50 mm x 66 m	16760
Stretch foil 0.5m x 300m, 20 µm thick	16765
Shore D measuring tool with drag indicator for hardness test of Pipecoat Plus	20304

# GRP Pipecoat Plus Casing Spacers 4 pipes

## Application manual

The system comes with gloves and adhesive tape. **Safety glasses should be worn during processing.**  
**Skin contact has to be avoided.**



1. Clean pipe surface, dry, degrease



2. Roughen with emery (corn 40-6)



3. Remove sanding residue and wrap anti-sliding tape with 100% overlap in required layers



4. **Moisten** surface incl. anti-sliding tape



5. Wrap the Pipecoat Plus tape with 100% overlap in required layers. **Spray water on the tape continuously during the wrapping process.** Time of processing 2-3 min., depending on temperature



6. Overwrap with clear foil or adhesive tape tightly



7. Check curing after approx. 60 minutes (approx. Shore D 70±)

### Remarks:

- A **processing temperature +5°C up to 25°C** is ideal
- Always adhere to all applicable health and safety regulations (REACH restrictions for DIISOCYANATE)
- The material must be **fully cured before pipe is pulled in**

The 4 pipes warranty only applies to faulty material. Checking the suitability of the product for the individual application is solely the responsibility of the user.



Pipeline Accessories

## Casing End Seals 4 pipes





## End Seals 4 pipes

Elastomeric casing-end seals serve as **pressure-less sealing** of the annular space between casing pipe and carrier pipe. To protect the carrier pipe against corrosion, the inside of the casing pipe has to stay dry. End seals are especially suitable for retrofit mounting and also for new constructions because they can be delivered individually (basic, multiple, conic, and split version). End Seals 4 pipes close the annular space at the end of the casing pipe around the carrier pipe, preventing any dirt or moisture from getting in. For pressure tight applications special measurements have to be taken e.g. type KMR.

When ordering we ask for **information of the exact pipe dimensions and spacer types** so we can choose the ideal seal.

- Type ADU wave shape - fix dimensions
- Type AKT/AWM end seal multidiameter design
- Type AST step shape
- Type AKG/AKO conic shape, AKO split possible
- Type ASTM individual end seal
- Type heat-shrinkable end seal

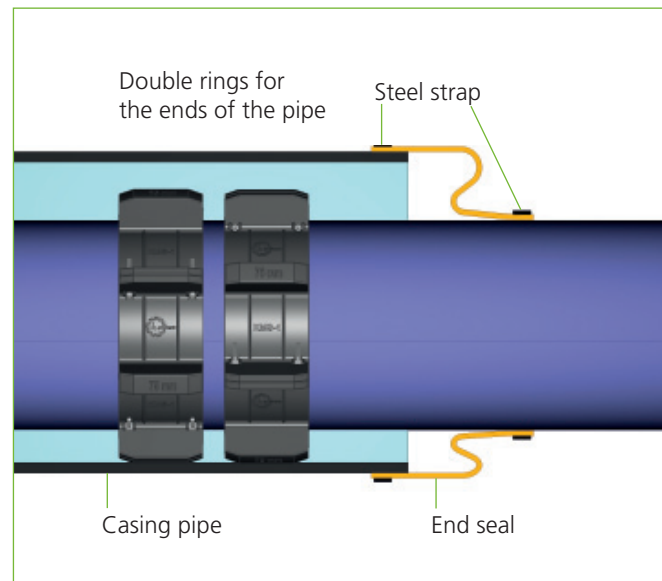



# End Seals 4 pipes

## Type ADU end seals

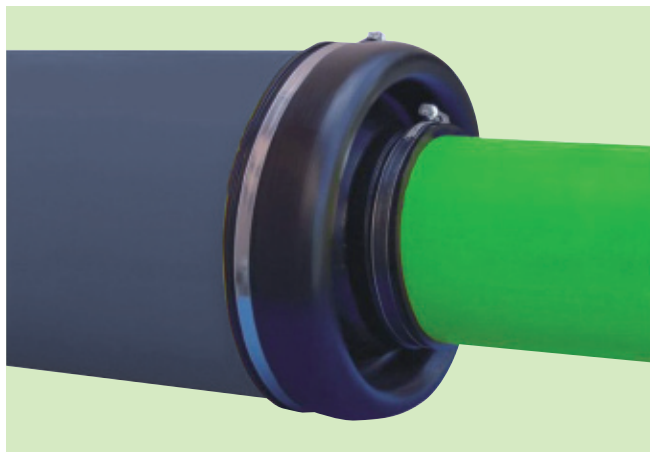

End seals ADU are a high quality and well-priced possibility to seal **standard combinations** of casing and carrier pipes with a rubber molded part. **Integrated waves** allow great flexibility and also enable also non-centric application. ADU end seals are stretchable up to 10%. For all standard sizes please have a look at our price list. A lot of further sizes are available on request. Using EPDM rubber and the suitable **stainless steel fastening straps** make the end seal a high quality product. Special qualities in silicone rubber are available on request. Operational temperature from -40° C up to +120° C  
**For all standard dimensions, please see our latest price list.**

### Installation Type ADU

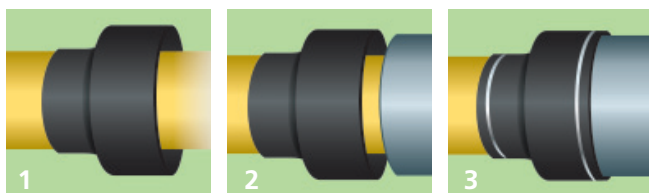

1. Insert the end seal on the main pipe before inserting the casing pipe
2. Insert the end seal on the jacket pipe
3. Secure both pipes with the supplied straps

## Type AST end seals

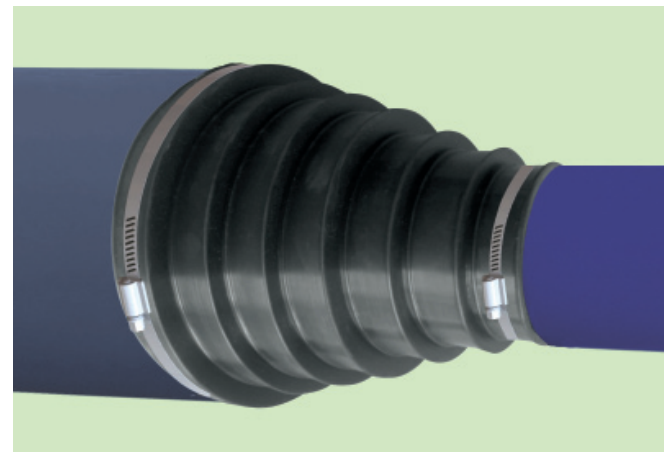

### Type AST:

- Only two types for 25 mm - 160 mm range
- High quality rubber
- Dimensions perfect for plastic pipes
- Marks for cutting on site
- Supplied with stainless steel straps
- Low stock, high flexibility
- NBR version for the gas sector
- Operational temperature from EPDM -40°C up to +120°C

Step dimensions in mm		DN	Art.-No.
Stepseal AST 20 - 90 closed	EPDM	20/30/40/50/ 75/90	18086
Stepseal AST 25 - 110	EPDM	25/32/40/50/ 63/75/90/110	18088
Stepseal AST 63 - 160	EPDM	63/75/90/110 125/140/160	18089
Stepseal AST 25 - 125	<b>NBR</b>	25/32/40/50 63/75/90/110 125	18087

# End Seals 4 pipes

## End seals Type AKT/AWM

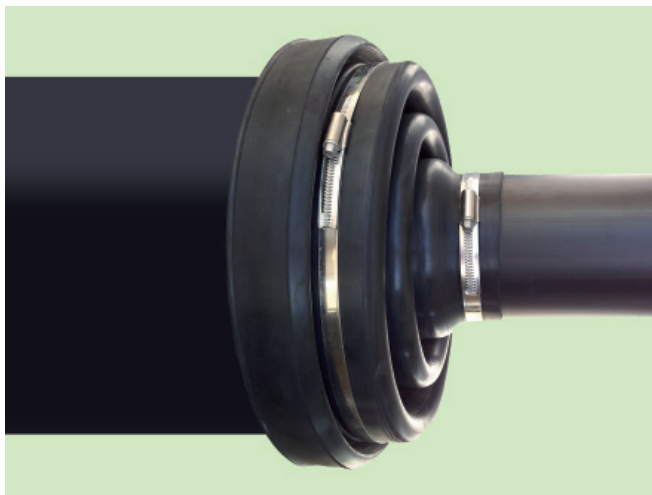

End seals AKT/AWM are made of high quality moulded EPDM-rubber. The conic shape of the seal allows a flexible cutting on various pipe diameters. The innovative AWM-seal although the cone is wave-shaped when delivered. AKT/AWM seals are available for a carrier pipes size up to 800 mm. Having only a small number of sizes makes storage easy for our distributors and sales partners..

Operational temperature from -40°C up to +120°C

### End seals Type AKT/AWM – Sizes

Dimensions in mm casing1/casing2 - min. OD carrier pipe	DN	Art.-No.
AKT 135/110-0	125/100-0	18090
AKT 215/165-0	200/150-0	18091
AWM 320/270-63	300/250-50	18092
AWM 402/350-80	400/350-80	18093
AWM 610/508-160	600/500-150	18094
AWM 810/710-273	800/700-250	18095

## Installation



1. The end seal type AWM comes with two stainless steel straps. The steel straps are adjustable individually for the largest as well as smallest pipe diameters.

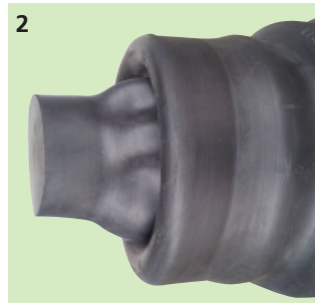

2. Pull the AWM seal over the carrier pipe until the contour of the pipe clearly begins to show (elasticity of the seal about 10 %). Thereby the AWM-seal unfolds to a conic shape which balances the eccentricities of the carrier pipe well.

3. Cut seal around carrier pipe's end.

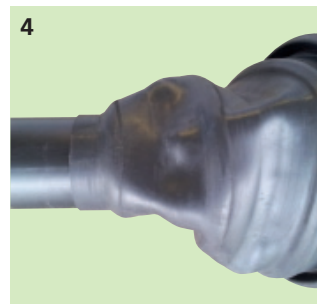
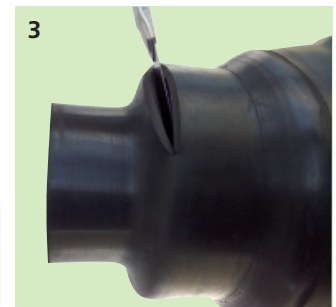

4. After that, push AWM-seal over carrier pipe and casing pipe.

5. After pushing the AWM-seal over both pipes, move the rubber seal into annular space for protection.

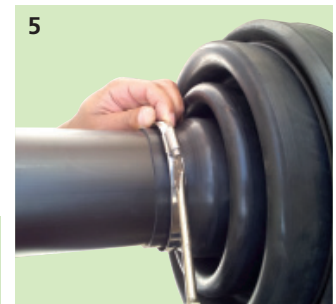

6. To conclude, fix AWM seal to the carrier pipe and casing pipe using steel straps.

# End Seals 4 pipes

## End Seal Type ASTM

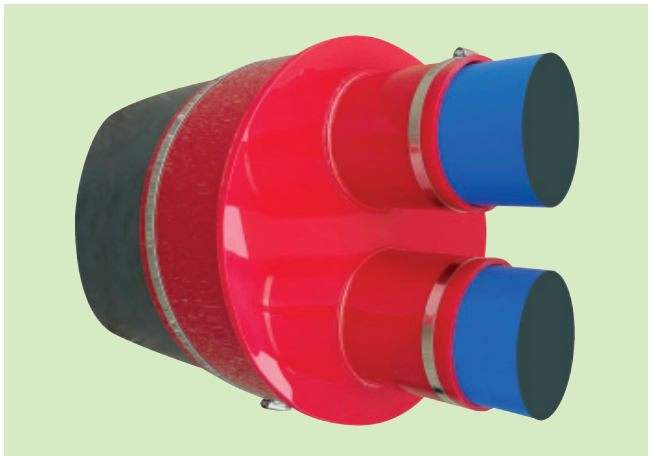

End seals type ASTM are the **highest quality** seal type between casing and carrier pipe. ASTM seals are made of soft PVC. Here you have the possibility to include **additional outlets** e.g. for further cable casing pipes. In special cases the welding of the seal on site for retrofit rehabilitation purposes is possible. ASTM-seals are **made individually** and are not available from stock.

A tightness against high external water pressure can be achieved by using a special sealing compound and double tightening straps (type ASTM-KMR). Standard colour is red.

**Stainless steel tightening straps** are also standard.

### Example/Template

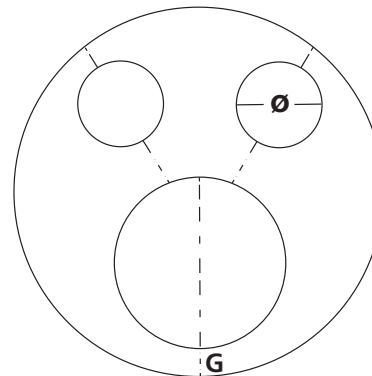

### Necessary information:

- OD casing
- Wall thickness casing
- Height of spacers
- OD carrier pipes
- Position carrier pipes

## Technical Data Type ASTM - soft PVC

Characteristics	Test method	Technical Data
Colour	-	red
Thickness	-	5 mm ± 0.30 mm
Break due to cold	DIN EN 1876-2	ca. -35°C
Working temperature min.	JEDI 35.008 / 35.010	ca. -5°C
Working temperature max.	JEDI 35.008 / 35.010	ca. +60°C
Water absorption	DIN 53472	0.1 % - 1 %
Elongation at break	ISO 527	≥ 360 %
Tensile strength	ISO 527	≥ 18 N/mm <sup>2</sup>
Tear growth resistance	DIN 53515	≥ 5 N/mm
Inflammability	DIN 53382 / DIN 4102/B2	Normally inflammable B2
Edge flaming	DIN 53382/2 / DIN 4102/B2	Self-extinguishing
Hardness Shore A	DIN 53505	77 ± 3
REACH-Conformity	-	Conform to (EG) Nr. 1272/2008 (REACH-regulation)
PAK-free	-	No polycyclic aromatic hydrocarbons are used in production
Silicone-free	-	Silicone is not part of the material and not used in the production process
RoHS	2011/65/EU the European Parliament	Raw materials meet the requirements of the JEDI document 35.012



# Installation guide

## Casing End Seals 4 pipes

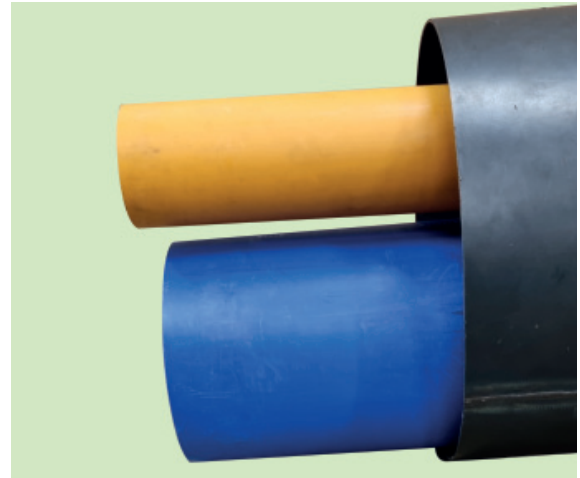

1. The casing end seal is supplied with a stainless steel tightening strap for the casing pipe and a stainless steel tightening strap for each carrier pipe opening.

2. Clean casing pipe and carrier pipes.

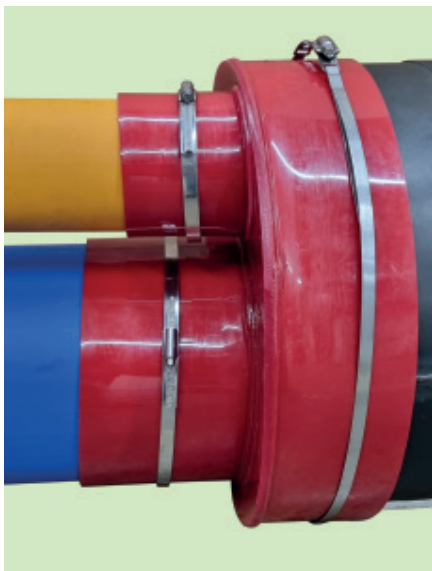

3. Pull casing end seal over carrier pipes and casing pipe, afterwards put the supplied tightening straps in place over the corresponding pipes.

4. Fasten the casing end seal on the carrier pipes and the casing pipe with the tightening straps.

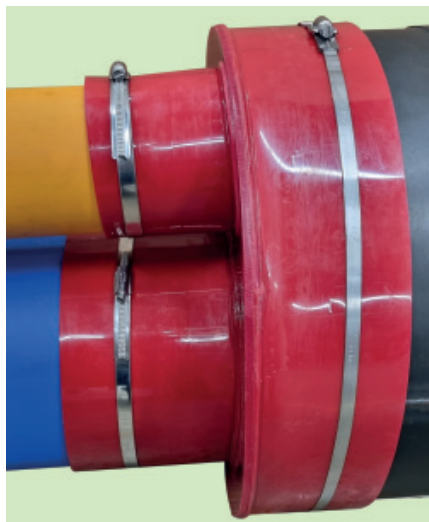

5. Correctly installed casing end seal type ASTM.



## End Seals Typ AKO and Type AKG 4 pipes

### End seals Type AKG/AKO



End seals AKG - AKO (split) are made for particular pipe combinations as a **conic cut**. The **individually-made seal** is available **for almost all pipe sizes**. For all standard pipe combinations please see our price list. Neoprene rubber with a consistent 2 mm thickness and the corresponding stainless steel straps make it a high quality and flexible product. Operational temperature from -30° C up to +70° C. Silicone rubber is available on request, only as closed version, temperature range -50° C up to +200° C.

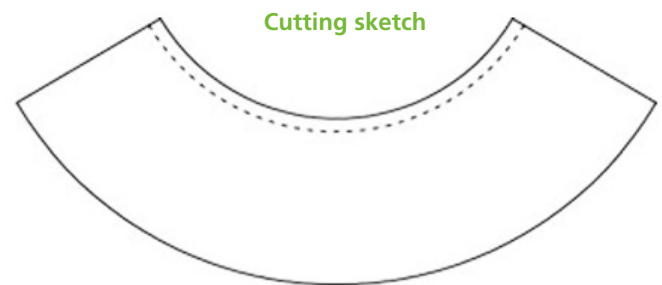

Carrier pipe DN (mm)	External jacket DN (mm)
25 up to 1300	37.5 up to 3000

**For standard sizes please have a look at our price list.**

If the casing end seal diameter is too small for the carrier pipe, scissors or a knife can be used on site to cut off the inner edge of the AKG or AKO end seal (20 mm result in a diameter increase of approx. 13 mm – 20 mm). It is important to ensure that in the area around the carrier pipe, the casing end seal is 2 - 5 % smaller than the outside diameter of the pipe, so that seal can be applied without wrinkles.

# Application Instructions

## Casing End Seals - Type AKO and Type AKG

Type AKG see point 5 and 6



The AKO casing end seal has to be prepared on a clean surface, with its two tapered bonding strips facing upwards.

**Attention:** The bonding strips have to be clean, dry and free of grease.

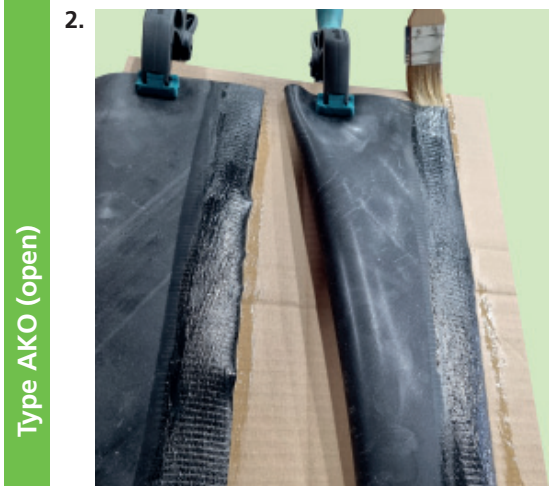

The bonding strips (width approx. 30mm) are thinly coated with the adhesive provided. The adhesive requires approx. 10 - 15 minutes to dry. A finger test is a reliable way to ensure the correct drying time; the adhesive should feel dry but still sticky.



After the adhesive on the bonding strips has dried sufficiently, the AKO end seal is wrapped around the carrier pipe.

**Attention:** The larger end of the casing end seal should point in the direction of the casing pipe.



Align the two bonding strips over each other and press them firmly together.

**Hint:** Use a pressure roller or a small wooden block to apply pressure evenly with an up and down motion.

Type AKO (open)



The larger end of the casing end seal is pulled onto the casing pipe until it is tightly in position. A stainless steel tensioning strap is then used to hold the end seal in place on the casing pipe.

Type AKG (closed)



After that, the end seal should be tucked in and then fastened securely to the carrier pipe using another stainless steel tensioning strap.



Pipeline Accessories

## Heat Shrink Products and Adhesives 4 pipes



# Heat Shrinking Tape NW 1250 4 pipes



### Description

Heat shrink tape **NW 1250** is used for **high-quality sealing** of components on pipe systems, e.g. from the jacket to the carrier pipe on a pre-insulated pipe. Designed as a 2-layer system, it is made from a high-quality, crosslinked polyethylene backing coated with a special butyl rubber-based adhesive. The backing material ensures **mechanical strength while the butyl rubber adhesive ensures save adhesion and tightness**. The system is **activated by heat**. A double 2-layer wrap provides extra mechanical protection.

### Properties

NW 1250 tape offers a **save seal on pipes and cables** as well as **high chemical resistance** to alkaline substances and many acids. The system is also suitable for buried applications. The backing thickness has been optimized and requires little heat input during processing. Together with a low preheat temperature, the assembly is very user-friendly, simple and fast.

### Structure of shrinkable tape

Backing (crosslinked polyethylene)

Adhesive (butyl rubber based)



[Installation video](#)

### Installation

The **pipe surface** must be **cleaned, degreased and dried**. After that it has **to be roughened**, e.g. with an emery cloth (grit 40 – 60), and **preheated to 60°C**. **Remove the protective foil** and wrap the shrink tape, adhesive side facing the pipe surface, centrally over the connection. First shrink the tape on the large diameter and then heat it up on the small diameter. Use a soft propane gas flame and heat pipe circumference. The shrinking process is finished when the shrink tape lies flat and wrinkle-free.

Technical Properties		
	Value	Test method
Backing thickness (as supplied)	approx. 0.3 mm	ASTM D 1000
Adhesive thickness (as supplied)	approx. 0.7 mm	ASTM D 1000
Tensile strength	240 N / 25 mm	ASTM D 1000
Shrink ratio	approx. 50%	

Dimensions		
Type	width x length	Art.-No.
Roll	160 mm x 10 m	16210
Roll	200 mm x 10 m	16211
Roll	250 mm x 10 m	16212
Roll	400 mm x 10 m	16213



## Filling Blocks DS 4 pipes



### Description

**4 pipe filling blocks for pre-insulated twin pipes**, together with a regular shrink system, ensure a uniform insulation end-cap. The filling block is „clamped“ between the two carrier pipes and enables the shrink system to be flush with the resulting ellipse. They are made from high-quality EPDM and are characterized by a high accuracy of fit and a long service life.

### Properties

The filling blocks provide a visual and physical closure to the twin pipe system for non-critical pressurized water applications. Due to their high thermal resistance up to +130°C, high UV resistance as well as a **high chemical resistance** to alkaline substances and many acids, a long service life is ensured. The standard range includes sizes from DN 20 to DN 200.

Special sizes are possible on request.

### Processing

**Pipe surface** must be **cleaned, degreased and dried**. Correct size shall be selected from our size chart. Filling block is placed between the carrier pipes so that it will be completely covered by the heat shrinking system being applied afterwards. Any tolerances can be compensated by using a butyl tape in addition. When applying the shrinking system, please make sure that the filling block is not directly exposed to the flame.

Heat shrink systems to be applied on top can be e. g. Canusa CSS endcaps, 4PMS tabular sleeve plus butyle or NW1250 tape system.



### Technical properties

Material	EPDM
Shore A	approx. 65
Thickness	approx. 40 mm
Colour	black

Title	Steel pipe sizes	Clearance between carrier pipe	Art.-No.
Filling block DN 20	OD 26.9 mm	20 mm	11040
Filling block DN 25	OD 33.7 mm	20 mm	11041
Filling block DN 32	OD 42.4 mm	20 mm	11042
Filling block DN 40	OD 48.3 mm	20 mm	11043
Filling block DN 50	OD 60.3 mm	25 mm	11044
Filling block DN 65	OD 76.1 mm	25 mm	11045
Filling block DN 80	OD 88.9 mm	30 mm	11046
Filling block DN 100	OD 114.3 mm	30 mm	11047
Filling block DN 125	OD 139.7 mm	35 mm	11048
Filling block DN 150	OD 168.3 mm	45 mm	11049
Filling block DN 200	OD 219.1 mm	45 mm	11050

Other sizes are possible on request

# 4 pipes Butyl Rubber Adhesive Tape Quality 52 Self-amalgamating

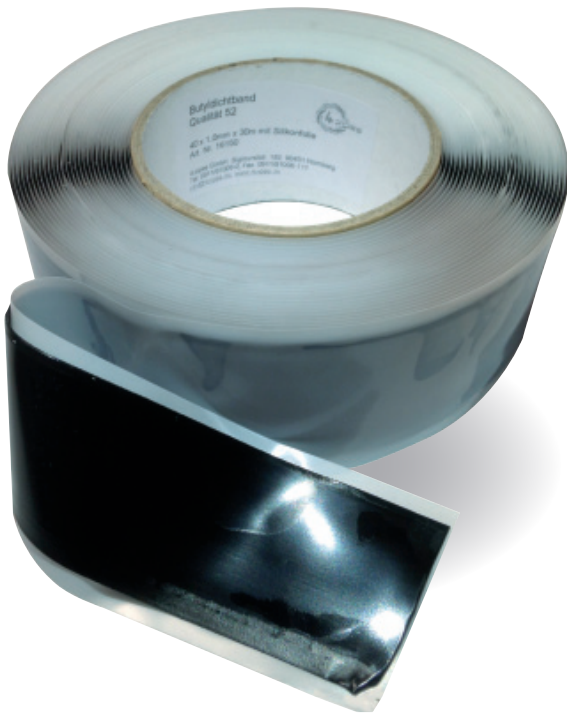

### Properties

- self-amalgamating
- high resistance to thermal distortion
- good ageing-resistance

### Applications

- Sealing tape for preinsulated pipe casings and shrinkable endcaps
- Sealing tape for endseals

### Handling

Processing by hand at least 5 °C

**Surfaces** have to be clean, dust-free, and dry and must show bearing strength.

**Attention:** Roughen the surface and preheat it to min. 40°C for a proper bond  
Peel resistance at 23°C: 30-35N/10mm  
On porous surfaces a butyl primer is recommended.

### Dimensions

**Strings** 1 x 40 mm, 1 x 50 mm and 1.5 x 100 mm  
special profiles possible

### Comments

**Safety** Avoid skin and eye contact.  
For further information, see safety data sheet.  
No hazard warnings necessary.  
Risk of burning at high application temperatures.

**Disposal** In accordance with local official regulations.

Technical data	
Base thermoplastic	butyl rubber
Colour	black
Density	1.5 (g/cm <sup>3</sup> ) - DIN 53479 B
Solids concentration	25 (1/10 mm) - DIN 51580 (5)
Thermal distortion	0 (mm) - IPM 5010
Solid content	> 99 (%) - IPM 5003
Ageing resistance	very good, unless exposed to UV light
Temperature resistance	-40 °C to + 90 °C, no shrinking, drying-out or embrittlement A short-term high temperature, e.g. installation of shrinking sleeves does not affect the tape negatively
Storage time	24 months
Storage best	in original carton 10 °C up to 25 °C



# Heat Shrink Sleeve 4PMS and 4PMSA 4 pipes

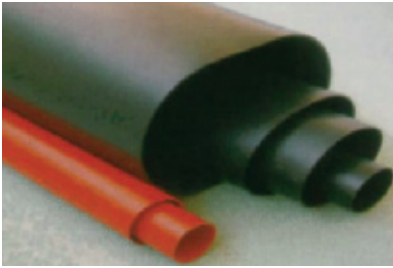

## Product description 4PMS and 4PMSA

Medium wall polyolefin tubular heat-shrinkable sleeve with excellent mechanical and electrical properties. Made for various applications, for low voltage electrical cable isolation or mechanical protection on pipes or pipe ends. Ideal as a **sealing system** and **corrosion protection system**, especially where low shrink temperatures, easy application and high flexibility are required.

- **Type 4PMSA = with adhesive**
- **Type 4PMS = without adhesive**
- medium wall thickness
- shrink ratio: 3:1
- climate and weather proof
- Standard colour black
- max. temperature +110°C
- minimum shrink temperature: 120°C
- moisture tight isolation
- high mechanical protection

Under 4PMS an additional, separate butyl adhesive can be applied. Butyl adhesive quality 22 with PP mesh inlay 50 x 1 mm x 15 m. **4 pipes Art. No.** 16169

**Application with a soft propane flame on a clean, dry and fat free surface.**



## Technical data 4PMS and 4PMSA

Test	Result
Operating temperature IEC 216	-55°C to +110°C
Tear resistance ASTM D 638	>14 MPa
Elongation at break ASTM D 638	>400%
Density ASTM D 792	1.05g/cm <sup>3</sup>
Change in length UL 224	0 bis up to 10%
Concentricity ASTM D 2761	<30%
Electrical resistance IEC 243	>20KV/mm
Copper-resistance ASTM D 2671	non corrosive
Water absorption ISO 62	<0.15%
Resistance to fungal attack ISO 846	passed
Peel resistance (PE) DIN 30672*	4 N/cm (4PMSA)
*without adhesive - Type 4PMS	

Type	Diameter as supplied min.	Diameter fully shrunk max.	Wall thickness max.	standard length*	Art. No. 4PMS	Art. No. 4PMSA
	mm	mm	mm			
95/25	95	25	3.0	1000	15531	15504
115/34	115	34	3.0	1000	15532	15505
140/42	140	42	3.0	1000	15533	15506
160/50	160	50	2.9	1000	15534	15507
180/60	180	60	2.9	1000	15536	15511
235/65	235	65	2.9	1000	15538	15508
265/65	265	65	3.0	1000	15539	15509
300/90	300	90	2.8	1000	15540	15510
350/150	350	150	2.8	1000	15541	on request
400/150	400	150	4.0	1000	15543	on request

Further colours, lengths and dimensions on request





# Sealing Adhesive Quality 22 4 pipes Special Butyl Tape with PP Mesh Inlay



### Product information

Sealing adhesive Q22 4 pipes is a high performance sealing and corrosion protection tape, which sticks on both sides. The **integrated PP-mesh** gives high cohesive stability to the system and avoids unwanted overstretch during the easy application process.

Even at higher temperatures, the special butyl gets softer, but does not flow or melt. The material keeps its function when there are no additional mechanical stresses.

As a sealing and corrosion protection tape, **under heat-shrinkable casings on preinsulated pipes as well as a separate adhesive under various shrink sleeves**, the tape has high performance for various applications in the pipeline and cable industry.

Sealing adhesive Q22 is self amalgamating and to be used without primer on metal and prepared plastic surfaces. High adhesion and flexibility as well as the special temperature resistance are the significant properties of the system.

### Application

Surfaces must be clean, dry, stable and fat/grease free.

**Attention: For a perfect adhesion, the pipe-cable surfaces need to be roughend with sand paper and preheated up to 40°C minimum.** On porous surfaces (e.g. concrete) the bonding surface needs to be prepared with 4 pipes butyl primer first.

Technical data	
Inlay	PP-mesh reinforcement
Thickness mesh	approx. 0.1 mm
Colour special Butyl adhesive Q22	black
Tear resistance	≥ 70N/25mm, DIN EN 14410*
Elongation at break	approx. 15 %, DIN EN 14410*
Interleaf	foil siliconised
Adhesive basis	Butyl rubber
Aging resistance	very good, when not exposed to direct sunlight and weather
Not resistant against	oils and liquids, such as gasoline
Peel resistance	≥ 15N/25mm, IPM 5009**
Stickiness	very high
Temperature range	-30°C to +120°C, No shrink, no dry out, no cracking. The short term exposure to higher temperatures, e.g. during the deventilation process of district heating pipelines, has no influence on the long term function.
Stock	in original carton at +10°C to max. +25°C

\* in accordance with the relevant DIN  
\*\* at 100mm/min, 90° tear angle

### Dimensions

roll 1,0 x 100 mm x 15 m Art. No. 16170

roll 1,0 x 50 mm x 15 m Art. No. 16169

roll 0,6 x 50 mm x 30 m Art. No. 16171

Other length and width on request.





# 4 pipes Butyl Rubber Adhesive Tape Quality 52 Certificate



  
**TEST CERTIFICATE**  
 489 1208 109bA  
 Tests according to EN 489:2003  
 for  
 non-welded joint system for district heating pre-insulated pipeline systems type  
**„Non-crosslinked shrinkable joint according to EN489 with  
 4pipes sealing tape quality 52“**  
 by order of  
**4pipes GmbH**  
 Test sample No. 3553, 3554, 3576:  
 Joint type  
 „Isojoint with 4pipes sealing tape quality 52“  
 on 2x DN 80/160 and 1x DN 150/250  
 Test report 1081E5034  
 The following tests have been completed in accordance with the European Standard  
 EN 489:2003 at the FFI for three non-welded joints in August 2012:  
 Soil stress tests and water impermeability tests.  
**The joints have passed the tests successfully and without damage.**  
 Hemmingen, 2012-08-15  
  
 Dipl.-Ing. Thomas Grage  
 Managing Director  
  
 FFI FERNWÄRME  
 FORSCHUNGSINSTITUT  
 GmbH  
 Max-von-Laue-Str. 23  
 30960 Hemmingen  
 +49 511 94370 0  
 www.fernwaerme.de  
  
 Dipl.-Ing. (FH) Volker Herbst  
 Project Manager  
  
Fernwärme-Forschungsinstitut GmbH  
 Max-von-Laue-Str. 23  
 30960 Hemmingen  
 Germany  
 www.fernwaerme.de  
 Managing Director  
 Thomas Grage  
 Reg. at  
 District Court  
 Hannover  
 HRB 287980  
 VAT-ID-Nr.  
 DE290815751

  
**CO-TEST CERTIFICATE**  
 to 489 2301 183a  
 System test  
 according to DIN EN 489-1:2020-03  
 for  
 the PE shrink joint casing system with sleeves type  
 „SUPERSEAL/T“ and Butyl adhesive tape “4 pipes Quality 52”  
 in the Dimension DN 80/160 and DN 150/250 with following components:  
 - PE shrink joint casing  
 - Butyl adhesive tape “4 pipes Quality 52”  
 - Shrink sleeves type “SUPERSEAL/T”  
 - Two welding plugs  
 - Thermal insulation foamed in the joint casing  
 By order of  
**4 pipes GmbH**  
 Test report 1755\_5487  
**The PE shrink joint casing system with shrink sleeves type  
 “SUPERSEAL/T” and Butyl adhesive tape “4 pipes Quality 52”  
 has passed the system test successfully.**  
 Hemmingen, 2023-02-06  
  
 Thomas Grage  
 Managing Director  
  
 FFI FERNWÄRME  
 FORSCHUNGSINSTITUT  
 GmbH  
 Max-von-Laue-Str. 23  
 30960 Hemmingen  
 +49 511 94370 0  
 www.fernwaerme.de  
  
 Volker Herbst  
 Project Manager  
  
Fernwärme-Forschungsinstitut GmbH  
 Max-von-Laue-Str. 23  
 30960 HEMMINGEN  
 GERMANY  
 Managing Director  
 Thomas Grage  
 VAT-ID-Nr.  
 DE290815751  
 District court  
 HANNOVER  
 HRB 287980  
 Approved Testing Laboratory



Pipeline Accessories

## Corrosion Protection Tapes 4 pipes

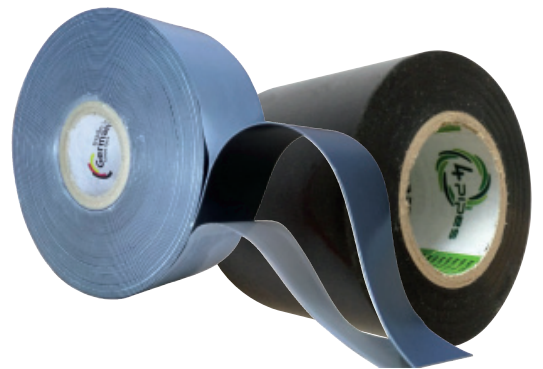

# Corrosion Protection Tape DUO40 4 pipes



## Product information

DUO40 4 pipes is a high quality cold applied corrosion protection tape, especially for welded joints and bends on underground steel pipelines. Because of its asymmetric construction with a thick (pipe side) and a thinner outer butyl rubber layer on the PE-carrier material, the overlap amalgamates perfectly.



Butyl rubber

PE-foil

Butyl rubber

The corrosion protection system is certified as a system with the primer HT accord. to Class C/50 with 4 layers and the class B/50 with 3 layers accord. to EN12068/DIN 30672.

DVGW No. B/50 (3 layers) NV-5180AR0756

DVGW No. C/50 (4 layers) NV-5180AL0188

Technical data	
Total thickness	0.8 mm ± 0.15 mm
Elongation at break accord. EN12068	≥ 600%
Tear strength accord. EN12068	11 N/mm
Peel resistance accord. EN12068	46N/10mm at 23°C
Tensile shear resistance on steel	0.2 N/mm <sup>2</sup>
Colour butyl outside	black
Colour butyl inside	light grey
Core inner diameter	42 mm
Width of roll	30, 50 oder 100 mm
Length of roll	15 m*

\* Special lengths are possible on request

## Application rate table

pipe diameter		OD pipe	width	primer consumption/ joint	when 2 x 50% overlap (4-layers)	
DN	inch	mm	mm	liter	total length	m <sup>2</sup>
25	1	33.7	30	0.01	5.93	0.18
40	1.5	48.3	30	0.02	8.50	0.25
50	2	60.3	30	0.02	10.61	0.32
65	2.5	76.1	50	0.02	8.03	0.40
80	3	88.9	50	0.03	9.39	0.47
100	4	114.3	50	0.04	12.07	0.60
150	6	168.3	50	0.05	17.77	0.89
200	8	219.1	50	0.07	23.13	1.16
250	10	273.1	100	0.09	14.42	1.44
300	12	323.9	100	0.10	17.10	1.71
350	14	355.6	100	0.11	18.77	1.88
400	16	406.4	100	0.13	21.45	2.15
450	18	457	100	0.14	24.12	2.41
500	20	508	100	0.16	26.82	2.68
600	24	610	100	0.19	32.20	3.22
700	28	711	100	0.22	37.53	3.75
800	32	813	100	0.26	42.91	4.29
900	36	914	100	0.29	48.25	4.82
1000	40	1016	100	0.32	53.63	5.36
1100	44	1118	100	0.35	59.01	5.90
1200	48	1219	100	0.38	64.35	6.43
1300	52	1321	100	0.42	69.73	6.97
1400	56	1422	100	0.45	75.06	7.51
1500	60	1524	100	0.48	80.45	8.04
1600	64	1626	100	0.51	85.83	8.58

- Length of tape is calculated with an extra amount of 5%
- Consumption of tape and primer can slightly differ in practice.
- **Estimated wrapping width of 400 mm per joint**



## Two-Tape System 4 pipes IT N15/OT PE3



IT N15

OT PE3

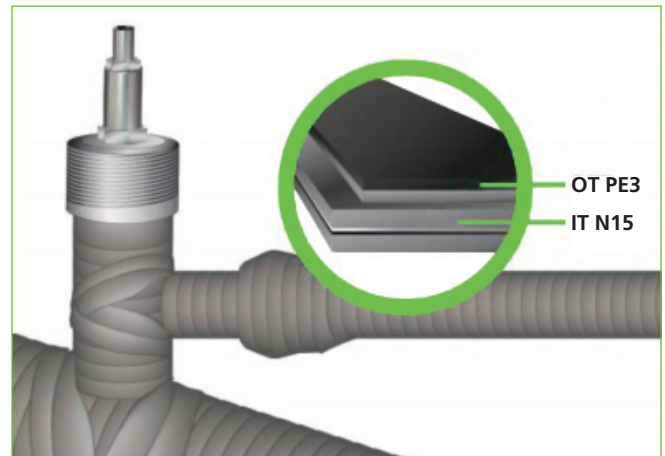

**Highly flexible** two tape system for the corrosion protection of steel pipes, pipelines and moulded parts according to DIN 30672 and EN 12068.

### Product information

4 pipes IT N15 / OT PE3 is a cold-processable two tape system for the corrosion protection of metal pipes and fittings. 4 pipes IT N15 / OT PE3 is optimized for the requirements in urban supply networks. The high flexibility and elasticity of 4 pipes IT N15 and 4 pipes OT PE3 enable a quick and safe application of the after-wrapping system to pipeline components such as T-pieces and house connection fittings. Also suited for pipes with small nominal widths, even in tight construction site conditions. The top layer PE3 is a two-layer tape with the carrier on the outside.

### OT PE3

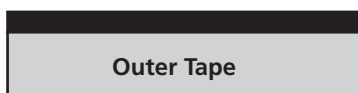

Outer Tape

PE backing  
Butyl rubber

### IT N15

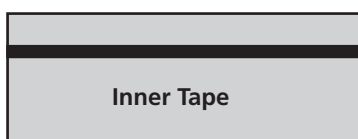

Inner Tape

Butyl rubber  
PE backing  
Butyl rubber

4 pipes IT N15 / OT PE3 is practically impermeable to water vapour and oxygen and is resistant to soil bacteria and electrolytes. 4 pipes IT N15 / OT PE3 is compatible with factory coatings made of PE, PP, FBE, PU, CTE and bitumen.

### Advantages:

- Especially thick and supple inner layer made of 1.5 mm butyl rubber tape
- DIN-DVGW approved system: B 30 (EN 12068)
- Excellent formability of the inner and outer tape
- Ideal for wrapping in distribution networks
- Compatible with factory coatings made of PE, PP, FBE, PU, CTE and bitumen

Technical data	
DVGW Reg, Nr.	NV5180CQ0257
Thickness adhesive	IT N15 = 1.5 mm ± OT PE3 = 0.4 mm ±
Thickness PE backing	IT N15 = 0.07 mm ± OT PE3 = 0.22 mm ±
Tear strength accord. EN 12068	10 N/cm <sup>2</sup> on steel
Peel resistance accord. EN 12068	15 N/10 mm at 23°C on steel
Colour backing	black
Colour butyl outside	grey
Colour butyl inside	grey
Core diameter	41 mm
Roll width	30, 50 or 100 mm
Roll length	IT N15 = 7.5 metre OT PE3 = 20 metre
Max. operation temperature	85°C for the whole system

Type	Art.-No.
4 pipes IT N15 grey 30 mm x 7.5 m	16660
4 pipes IT N15 grey 50 mm x 7.5 m	16661
4 pipes IT N15 grey 100 mm x 7.5 m	16662
4 pipes OT PE3 black 30 mm x 20 m	16665
4 pipes OT PE3 black 50 mm x 20 m	16666
4 pipes OT PE3 black 100 mm x 20 m	16667
Primer HT, 1 litre can	16580
Primer HT, 5 litre can	16581

### Application:

with Primer HT, IT N15 with 50 % overlap (two layers), and OT PE3 with 10 mm overlap (one layer) on top.

### Class:

- wrapping EN 12068 - B 30
- wrapping DIN 30672 - B 30





# Two-Tape System 4 pipes IT N15/OT PE5



**Flexible** two tape system for the corrosion protection of steel pipes, pipelines and fittings according to DIN 30672 and EN 12068. For **extreme corrosion conditions and mechanical loads**, also on uneven surfaces.

### Product information

4 pipes IT N15 / OT PE5 is a cold-processable two tape system for high-quality corrosion protection of metal pipes and fittings with particular suitability for use on uneven surfaces and with complicated geometries. A highly flexible butyl rubber adhesive layer of 1.5 mm thickness enables the 4 pipes IT N15 to adapt optimally to uneven surfaces, even with complicated geometries. The top layer PE5 is a two-layer tape with the carrier on the outside.

### OT PE5



### IT N15

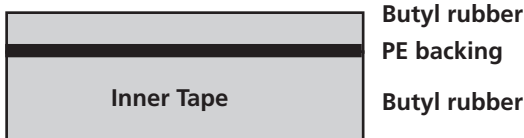

4 pipes IT N15 / OT PE5 is practically impermeable to water vapour and oxygen and is resistant to soil bacteria and electrolytes. 4 pipes IT N15 / OT PE5 is compatible with factory coatings made of PE, PP, FBE, PU, CTE and bitumen.

### Advantages:

- Especially thick and supple inner layer made of 1.5 mm butyl rubber tape
- Excellent for uneven surfaces
- Excellent corrosion protection with particularly easy application
- DIN-DVGW approved system: C 30 (EN 12068, DIN 30672)
- Compatible with factory coatings made of PE, PP, FBE, PU, CTE and bitumen

Technical data	
DVGW Reg, Nr.	NV5180AL0257
Thickness adhesive	IT N15 = 1.5 mm ± OT PE5 = 0.5 mm ±
Thickness PE backing	IT N15 = 0.07 mm ± OT PE5 = 0.3 mm ±
Tear strength accord. EN 12068	10 N/cm <sup>2</sup> on steel
Peel resistance accord. EN 12068	15 N/10 mm at 23°C on steel
Colour Backing	black
Colour butyl outside	grey
Colour butyl inside	grey
Core diameter	41 mm
Roll width	30, 50 or 100 mm
Roll length	IT N15 = 7.5 Meter OT PE5 = 15 alt. 30 Meter
Max. operation temperature	85°C for the whole system

Type	Art.-No.
4 pipes IT N15 grey 30 mm x 7.5 m	16660
4 pipes IT N15 grey 50 mm x 7.5 m	16661
4 pipes IT N15 grey 100 mm x 7.5 m	16662
4 pipes OT PE5 black 30 mm x 15 m	16675
4 pipes OT PE5 black 50 mm x 15 m	16676
4 pipes OT PE5 black 50 mm x 30 m	16677
4 pipes OT PE5 black 100 mm x 30 m	16678
Primer HT, 1 liter can	16580
Primer HT, 5 liter can	16581

### Application:

with Primer HT, IT N15 and OT PE5 with 50 % overlap each (two layers).

### Class:

- wrapping EN 12068 - C 30
- wrapping DIN 30672 - C 30



## MonoTape 710.35 4 pipes



### Product information:

Monotape 710.35 is a highly flexible corrosion-protection and sealing tape with excellent mechanical properties and stability. The tape system ist DIN DVGW certified acc. to class B/30 DIN 30672 / EN 12068 with only two layers as a minimum.

MonoTape 710.35 is especially designed for hand application, often necessary on e.g. bend and elbows.

The system is first choice for coating of bends end elbows on steel pipelines.

A wrapping machine can also be used on site or in the factory.



PE backing

Butyl adhesive

The High quality PE-Compound backing and the special butyl adhesive allow applications up to 80°C permanent pipeline temperature. This level is beyond the DIN approval and rated internally by the manufacturer.

Smart packaging without release liner makes this system very user-friendly on site.

The consumption for the various pipe dimensions is shown in our tables. Consider half the volume for 1x50% overlap only. Please use our **online tape calculator** under [www.4pipes.de](http://www.4pipes.de)

### Application:

Application of the tape is done acc. to DVGW GW15 regulations, with a minimum of 1x50% overlap (two layers) and primer IW 700-23.



### Technical data

Tape thickness	0.9 mm ± 0.15 mm
Thickness adhesive	0.66 mm
Thickness backing	0.24 mm
Colour backing	black
Colour butyl inside	black
Elongation at break	400%
Peel resistance	17N/10 mm at 23°C
Operation temperature	-35°C bis 80°C intern
Core diameter	41 mm
Class	B/30 DIN 30672 / EN 12068

### Standard dimensions Monotape 394.40

Roll width (mm)	50	100
Rolls/Carton	24	12
Length/Roll (m)	15	15

Other lengths and widths are available on request.  
Recommended Primer: Primer 700

### Storage:

These products should be stored without exposure to UV at a temperature between 10°C and 30°C.

The 4 pipes warranty only applies to faulty material. Checking the suitability of the product for the individual application is solely the responsibility of the user.



Registration No. DVGW:  
DV-5180CP0096

## Application Instructions

Pipe surface has to be dried, cleaned and degreased according to DVGW-regulation GW15. PE-cleaner is recommended for degreasing. Roughen the dry pipe surface with emery cloth. The temporary edge protection paint at the transition from PE to steel has to be removed.

Drying the surface should be done using a soft propane flame. The temperature of the pipe surface has to be  $\geq 5^{\circ}\text{C}$  and the tape has to be warmer than  $10^{\circ}\text{C}$ . At the transition to steel the PE-coating has to be beveled at an angle of max.  $30^{\circ}$ , preferably with a PE rasp. All loose parts, as well as polish and emery flakes, have to be removed.

The dry and clean surface including about 100 mm of the factory coating has to be painted with **Primer HT** well before handling (**Primer 700 for MonoTape 710.35**).

The primer drying time is about 5 to 10 min. On average, the consumption is about  $0.25\text{l/m}^2$ . After about 6 hours or a new contamination, the priming process has to be repeated. Higher profiles, e.g. a welded seam, have to be adjusted with a filler to guarantee smooth application.

Wrap the tape under slight tension with 50% overlap (first layer), in doing so remove release layer. Overlap starting end of the wrapping with itself and minimum 50mm on the factory coating. Overlap the first wrapping of a new roll when attached and also include the end piece of the previous roll 100 mm.

As an outer layer, apply a further wrapping on top under slight tension. The class C/50 is reached with minimum overlap of 50% (altogether 4 layers) and the class B/50 with an overlap of about 10 mm (altogether 3 layers). The outer wrapping should cover the inner one by about minimum 10 mm at both ends.

**Class B/30 can be achieved with 1 x 50% MonoTape 710.35.**

**The end of the tape should point down** without tension and be pressed on firmly.

**Before back filling or performing a destruction test**, the corrosion protection system should amalgamate for **minimum one hour**.

The 4 pipes warranty only applies to faulty material. Checking the suitability of the product for the individual application is solely the responsibility of the user.

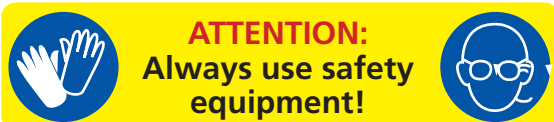
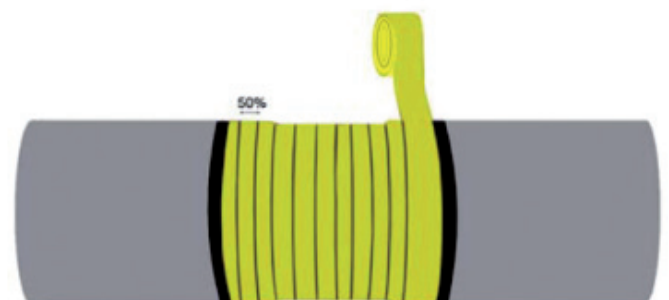
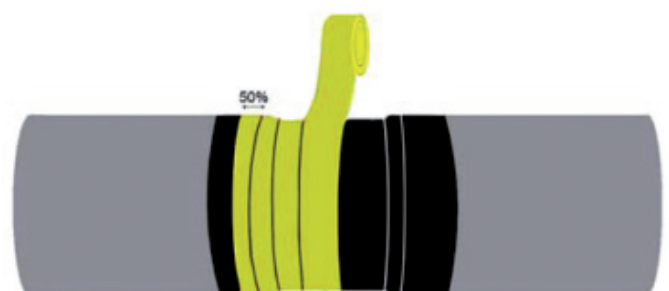
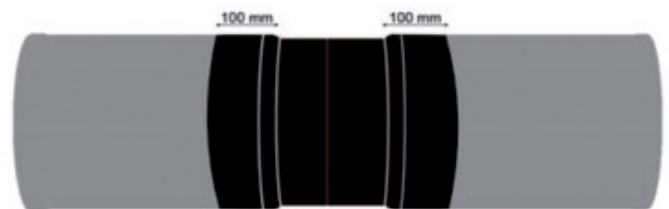
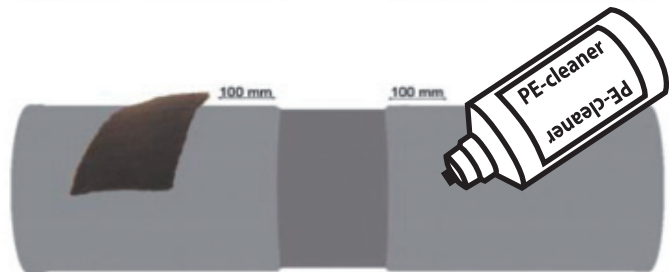
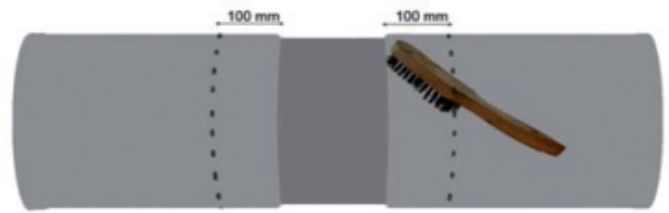



# ISO-Petrolatum Tape 4 pipes - Type PE 1,5

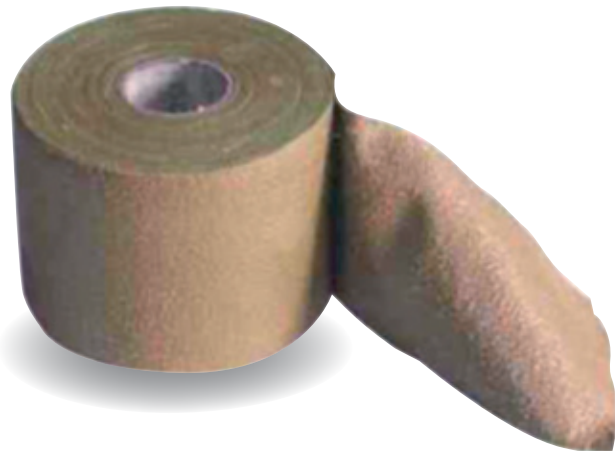

**Petrolatum corrosion protection coating accord. to EN 12068/DIN 30672 class A/30 - 2 layer system**

## Composition

4 pipes petrolatum tape is a corrosion protection tape consisting of a synthetic fibre inlay (185g/m<sup>2</sup>), both sides coated with a modified petrolatum filler with high adhesion and flexibility applied on a HDPE-foil.



**HDPE-foil**

**Fabric soaked with petrolatum**

## Application area

For coating of welded joints and fittings as well as valves, house connections, flanges and lightning-protection system. The ISO-petrolatum tape is especially suitable for complicated parts in connection with the petrolatum filler ISO-Mastic. DIN class A, operating temperature up to 30°C.

## Technical data

Weight: approx. 1.9 kg/m<sup>2</sup>  
 Thickness: 1.5 mm ±0.1 mm  
 Colour: beige to brown  
 (colour difference doesn't affect quality)

## Dimensions

Roll length 10 m  
 Width 50, 100, 200 and 300 mm  
 Packing unit/box 24, 12, 6 and 4 rolls

## Advice for storage

Protect from direct sunlight, store dry, standing on its cut edges, stacking height maximum 4 boxes.

## Application

Use a wire brush to de-rust and clean the area which will be wrapped. The surface has to be free from grease, clean and dry. Spiral wrapping must then be performed under tension with at least **50% overlap (2 layers)**. It begins and ends with 50 mm overlap to the factory coating. The attached foil has to be on the outside. Please ensure a wrinkle-free wrapping without cavity setting. Press and smoothen tape especially in the area of overlap for the finish.

We recommend using the 4 pipes-rockshield fleece in addition when mechanical forces are expected.

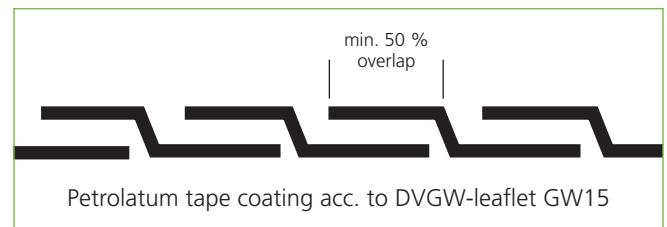

**Registration No. DVGW:  
 NV – 5180 BO 0011**

# Butyl Filler 4 pipes



Filler Bars



Pic. 1

Filler Tape

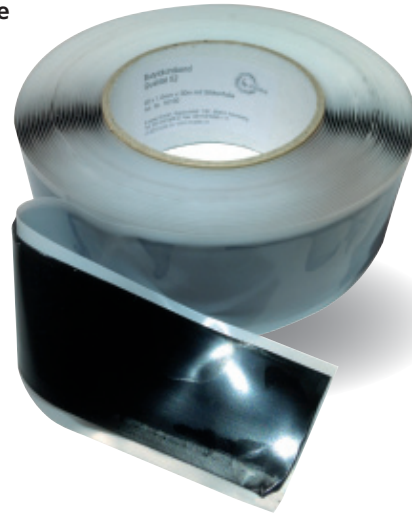

Pic. 3



Pic. 2



Pic. 4

## Product description

Butyl Filler 4 pipes is a highly flexible, moisture and aging resistant filling material that facilitates hollow-free, passive pipeline corrosion-protection coating on site for high-profile parts, such as flanges, bells or fittings. (Pic. 1)

The material can be quickly and easily moulded by hand into various shapes on site. (Pic. 2)

Butyl Filler 4 pipes is suitable to be used in combination with almost all standard passive corrosion protection systems like butyl, petrolatum or bitumen tapes as well as heat shrink materials. (Pic. 4)

Adhesion to the pipe surface and the good corrosion protection properties can be optimised by using a butyl primer before applying the filler. Pipe surfaces need to be dry, clean and fat free. 1 Kg bars, single packaged in special paper, make the filler easy to use on site.

To fill smaller gaps, e.g. around a welded seam, high quality butyl is available on rolls 40 mm x 1mm. The rolls per 30 m are supplied with an extra wide release foil. (Pic. 3)

## Usage

The butyl filler has to be applied by hand. Use a proper amount of filler and shape it on the surface. Press the filler tightly in all gaps.

Technical Specifications and Properties	
Basis	butyl rubber
Colour	beige
Density (DIN 53479/B)	1,9 g/ml
Aging resistance	very good if not exposed to direct weathering
Temperature resistance	-40°C up to +90°C, no shrinking, drying out or embrittlement
Storage	+5°C up to +25°C

Description	Art.No. 4pipes
Butyl filler bars 6 Kg	16636
Butyl Rolls 40 mm x 1 mm x 30 metres	16150
Butyl Rolls 50 mm x 3,5 mm x 7,5 metres	15410

The 4 pipes warranty only applies to faulty material. Checking the suitability of the product for the individual application is solely the responsibility of the user.

## Espansit II Butyl Tape 4 pipes

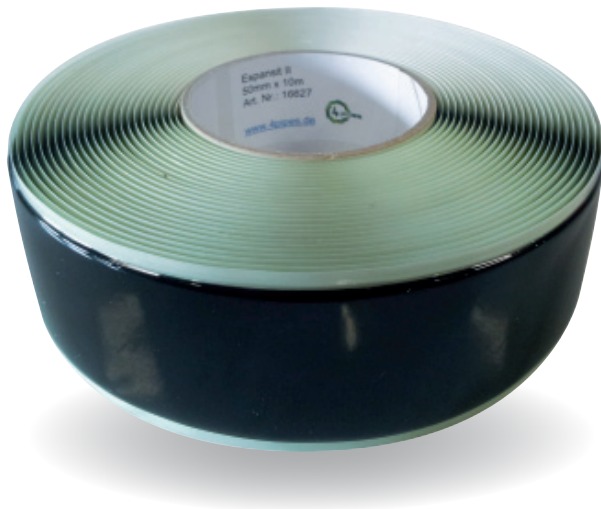

### Product information

Espansit II is a high quality butyl rubber tape for passive **corrosion protection on complicated steel fittings**.

The tape is also suitable as a repair system to seal surface defects e.g. on pre-insulated flexible pipe systems.

A simple and secure application on site without primer and a high flexibility of the polypropylene carrier material characterizes this tape. A siliconised release liner guarantees a user-friendly application.

This system ensures a complete water tight coating which is highly resistant against microorganism as well as thinned acids and alkalis. For mechanical protection the 4pipes-KU-protective tape or 4 pipes pipe protection fleece can be wrapped over the applied Espansit II tape in addition.

Application accord. DVGW GW 15, to be wrapped with minimum 50% overlap (2 layers) and slight tension on the clean, fat-free and dry pipe surface.

The tape has a good adhesion strength on metal and plastic surfaces.

The 4 pipes warranty only applies to faulty material. Checking the suitability of the product for the individual application is solely the responsibility of the user.

### Technical data

Mechanical characteristics	
Colour	black
Length	10 m
Width	50/100 mm
Supporting material thickness	25 my
Total thickness DIN EN 1942*	ca. 2.0 mm
Elongation at break DIN EN 14410*	≥ 300 %
Tensile strength DIN EN 14410*	2.0 N/mm
Peel resistance	1.5 N/mm

Electrical characteristics		
Dielectric strength	15 KV/mm	ASTM D 149

\* according to the particular DIN



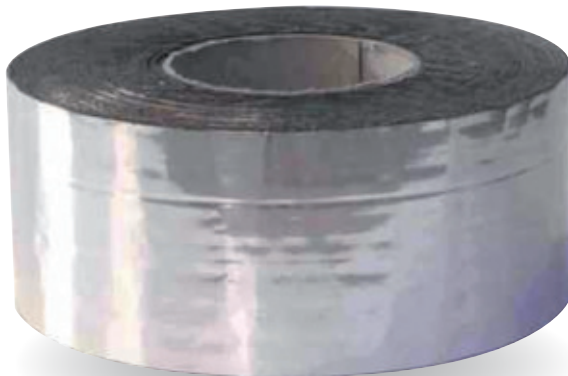

### Usage

The AluTape 4 pipes seals and sticks to metal, plastic, concrete, stonework, plaster, wood or glass. The application for pipeline construction is basically the **UV and corrosion protection for above-ground pipelines**. Furthermore the tape can be applied as a **diffusion barrier** on pipe systems.

It is also suitable for the sealing of joints, cracks, gutters, connections on roofs and walls, covers, glass roofs and greenhouses, steel constructions, roof coverings and flashing boards.

### Application

The surfaces which have to be sealed should be clean, dry and free of frost, fat and silicone. Porous or dusty underground should be pretreated with a priming (about 200ml/m<sup>2</sup>) to get an optimum bonding.

When primer V is used, please mix well and paint the area where the tape should be applied. Let the primer cure for minimum 10 minutes until it is not sticky any more. If the tape is not applied within two hours, the priming process has to be redone.

The best processing temperature is between 5°C and 45°C, pipe-surface temperature. If it is colder the tape can be warmed up with a propane flame or hot air gun (attention: consider safety regulations).

The AluTape 4 pipes must be pressed on tightly to avoid air entrapment.

To be wrapped with min. 50% overlap (2 layers). Not approved for underground pipeline corrosion protection.

### Storage

The product has to be stored away from sunlight at between 10°C to 30°C. The rolls should be kept dry and standing flat on their edges. This product is not sensitive to frost. The characteristics of the AluTape 4 pipes remain unchanged for a long time. An application within 12 month is recommended.

### Technical data

AluTape 4 pipes is a self-adhesive and cold-applied sealing tape. The aluminium foil is specially plastic-finished on the surface, UV-resistant and therefore has a good mechanical stability. The adhesive consists of elastomeric bitumen and high quality adhesive resins, which are protected by a silicone-coated release foil.

Complete tape thickness	1,1mm ± 0,15 mm
Colour outside	aluminium-blank or lead coloured*
Building material class	B2, normal inflammable DIN 4102
Softening point	≥ 85 °C DIN 52011
Cold bending behaviour	≥ - 30 °C DIN 52 123
Highest tensile strength	> 200 N DIN EN 12311-1
Water tightness	tight DIN EN 1928
Tearing strength	30 N DIN EN 12310
Steam transmission	sd > 1500 m DIN EN 1931

\*special version

### Standard delivery types

Roll width (mm)	50	100
Rolls/boxes	24	12
Length/roll (m)	10	10
Art. No.	16550	16551
Other packing units on request		
Recommend primer:	Primer V 1 liter	Art. No. 16595
	Primer V 5 liter	Art. No. 16596

The 4 pipes warranty only applies to faulty material. Checking the suitability of the product for the individual application is solely the responsibility of the user.

## KU Self-adhesive Tape 228sk 4 pipes



### Product description:

KU self-adhesive tape 228sk 4 pipes is a **highly flexible** multi-functional material.

The tape is a perfect **mechanical protection** on top of very soft corrosion protection systems, like e.g. petrolatum tapes or viscoelastic anti-corrosion tapes.

Because of its high flexibility it is suitable for applications on very complicated parts like T-pieces or elbows etc.

A unique feature is the tape's **flexibility** at low temperatures down to **minus 18°C**.

As a multi-purpose tape it is also used for all kinds of **sealing and fastening** in day to day applications.

**KU tape is also perfectly suitable as an electrical isolation tape.**

The outstanding characteristics of this tape are high resistance to abrasion, moisture, oils, mild acids and alkalis, as well as good resistance to weathering.



### Technical data

Material	PVC
Thickness	0.19 mm ± 0.01 mm
Length	10 meters
Width standard	50 mm – (other on request)
Colour standard	black
Elongation at break	250 %
Adhesion layer/layer	1.9 N/10 mm
Electrical resistance	10,3 kV
Max. operating temperature	90°C
Self-extinguishing	-

### Application

The tape should be applied on a dry, clean and fat free surface. To be wrapped with tension and minimum 50% overlap.

The 4 pipes warranty only applies to faulty material. Checking the suitability of the product for the individual application is solely the responsibility of the user.

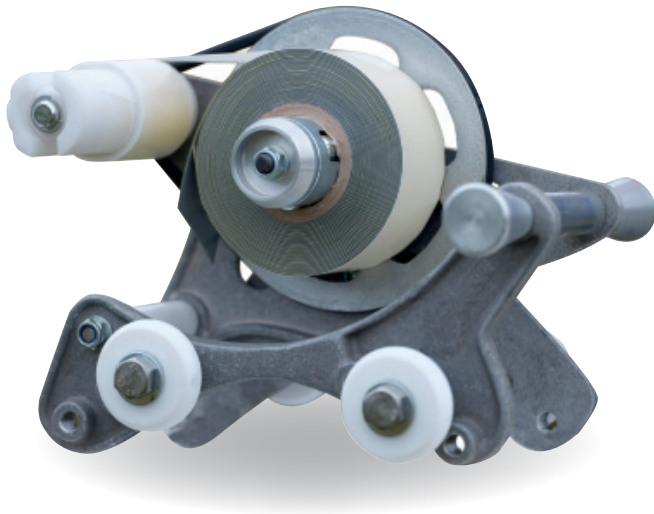

- Wrapping machine for tape width up to 100 mm, for core 41 mm – Art.-No. 16600

### Product information

The hand-wrapping machine is designed to apply corrosion protection tapes on pipelines and elbows of different kinds and dimensions.

The standard wrapping machine is suitable for tapes up to 100 mm width.

In the ditch a minimum space of 400 mm around the pipeline is required to work with best results.

Pay attention that all four rollers have contact to the pipe surface during the wrapping process to achieve best quality.

### Advantages

- Easy effort-saving wrapping
- Continuous tension adjustable
- Quick change of tape-rolls
- Integrated automatic wrap-up of the release foil
- Overlap adjustable easily
- For 41 mm tape-core ID's
- For pipe dimensions DN 80

The machine can quickly be adjusted for different tape width. The necessary spare parts come as part of the kit.





Pipeline Accessories

Mechanical Pipeline  
Protection 4 pipes

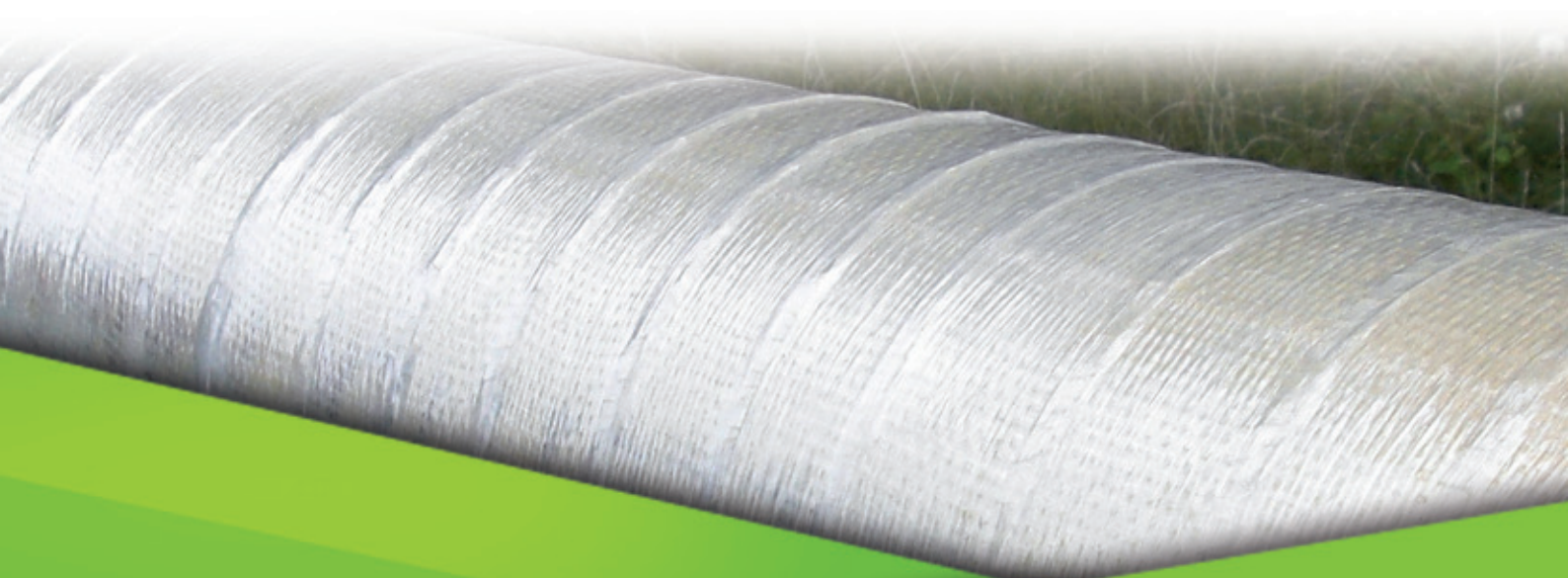
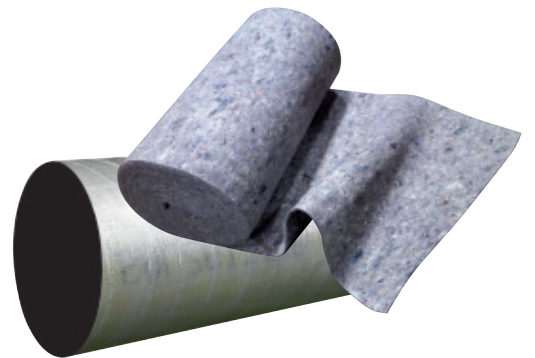

# Fibercoat Ultra 4 pipes

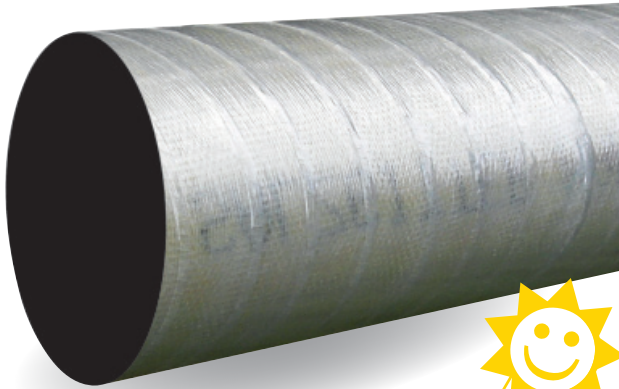

### Product information

Fibercoat Ultra is a glass-fibre-reinforced composite material in third generation. The roll material is delivered ready to apply and **pre-impregnated** with resin and cured by UV light. Mixing and laminating on site is not necessary. A handy roll size of 150 or 300mm width provides a simple and secure application. A special GRP system, which was developed to fulfil the most stringent requirements for trenchless traverses, is characterised by the following attributes:

- Glass-fibre woven texture bandage, no short fibre pieces, which have highest stability
- Thickness per layer is only 0.9 mm ± 0.1 mm. Therefore the system is extremely flexible.
- The bandage is very translucent and allows the hardening up to 8 layers coating thickness in one process
- Extreme impact strength and shearing resistance
- Capable of protecting the complete pipeline

### Pipeline Application

Typical application areas for pipeline construction are mechanical protection with regard to

- Trenchless pipeline laying, especially HDD
- ground-air changeovers
- pipe bearings, brackets and hangings

### Advantages

Because of the pre-impregnation of the system from factory side, an optimized protection of the environment is ensured. A common dripping of the resin does not occur as with classical laminations. The system comes with all necessary accessory material which includes special gloves, clear foil for pressing on the pipe surface, on request also UV-lamps etc.

Technical data		
Thickness		approx. 0.9 mm layer
Density	DIN EN ISO 1183-1	1.54 g/cm <sup>3</sup>
Tensile strength	EN ISO 527-4	240 N/mm <sup>2</sup>
Bending strength	DIN EN ISO 178	200 N/mm <sup>2</sup>
E-module	DIN EN ISO 178	11800 N/mm <sup>2</sup>
Fracture elongation	DIN EN ISO 178	1.5 %
Compressive strength	DIN EN ISO 604	> 200 N/mm <sup>2</sup>
Notched impact strength	DIN EN ISO 179	70 KJ/m <sup>2</sup>
glass-fibre content	DIN EN ISO 1172	50 % ±2
Resin content	-	50 % ±2
Volume shrinkage	ISO 2577	1 %
Water absorption	DIN EN ISO 62	0.17 mg/100h
Styrene emission		< 20 ppm
Hardness Shore D	DIN 53505	approx. 80°C*

\*fully hardened

Material data using a 2 mm thick test plate. Tolerances possible. Excellent resistance against chemicals (resistance table on request)



Ground to air protection



Under pipe clamps



# Fibercoat Ultra 4 pipes

## Application instructions

- **Do not apply inside closed rooms**
- **Clean, dry, degrease** pipe surface, roughen with sand paper (corn 40-50)
- **Apply in a shaded area!**
- **Spiral wrapping** (2 to 8 layers)
- **Wrap tightly** and after that **overwrap with clear foil**
- During work interruptions, **secure transition zone from light** (e.g. with adhesive tape or the black packaging foil) to continue on non-hardened material, wet-in-wet
- **Working time max. 5 minutes**, max. 10 minutes when cloudy
- **Protection against direct UV-light is mandatory**, e.g. with a tent during application
- **Protect skin and eyes (with sunglasses) against UV-light! Do not work near active UV-spots!**
- Wrapping and hardening **up to 8 layers in one single process** is possible
- The **shady side of the pipe should be hardened with a UV-lamp** (2 UV-lamps minimum)
  - Distance lamp to pipe approx. 500 mm
  - Number of lamps should be higher on larger pipe diameters
  - The complete pipe surface must be covered by UV-light
  - Hardening time 5 minutes / layer at 20°C (e.g. 20 minutes for four layers)
  - Proceed in 500 mm steps along the pipeline
- Intense UV sunlight can help to shorten the curing time.
- For coating of pipes and coating systems for trenchless applications **consider valid DVGW-regulations**
- Optimum **application temperature +5°C up to 25°C**
- **Prevent pollution of the material**, otherwise this would lead to hardening failures
- Application always accord. to **regional standard health and safety regulations**
- Material must be **hardened fully** before mechanical load is applied (**shore D 80 ±**)

**To coat pipeline parts** e.g. welded joints, wrap on the mill coating should overlap **at least 200 mm on both sides**. The wrapping has to be applied as flat to the surface as possible to avoid any harsh edges. For a final quality check, apply a test piece to the most-tricky area. Remove this piece before deployment and carry out a hardness measurement. A warranty for Fibercoat Ultra 4 pipes is limited to replacement of faulty material only.

The 4 pipes warranty only applies to faulty material. Checking the suitability of the product for the individual application is solely the responsibility of the user.



Description	Art.-No.
Roll 150 mm x 15 m	16708
Roll 300 mm x 15 m	16709
Adhesive tape transparent 50 mm x 66 m	16760
Stretch foil 0.5m x 300m, 20 µm thick	16765
Gloves for Fibercoat Ultra application	16770
UV-Spot 400 Watt	16750
Shore D measuring tool with drag indicator for hardness test of Fibercoat Ultra	20304



Application video



Shore D Measuring Tool



UV-Spot





# Pipecoat Plus 4 pipes - FRP water-curing

## FRP water-curing on sites Premium mechanical protection



### Product information

Pipecoat Plus is a **fiber-reinforced composite material**. The material is pre-laminated with resin on a roll and cures with water. A **mixing or laminating on the site is not necessary**. The roll which comes in an airtight bag has to be sprayed with water during application.

**Application is easy** because of the **manageable size of the roll with 100 or 150 mm** width.

The specially-developed FRP-System for pipelines fulfills the highest standards and has following features:

- **Woven** fibre-bandage (no short fibre pieces) is guaranteed **highest stability**
- **Extremely flexible**
- The bandage allows the **curing of up to 20 mm thickness** in one process.
- **Extreme shock and shear resistance**
- Especially suitable for **protection of welded joints**
- **Fast curing** and almost full capacity after about 60 min. (23°C/74°F)
- Application is **also possible under water**

### Usage

Typical **applications at pipeline constructions are the mechanical protection** on

- **trenchless technologies**, especially HDD, on welded joints (for complete pipe coatings please use FibercoatUVcure)
- **soil-to-air interface area**
- **under pipe brackets clamps and hangers**
- use as **casing spacer in small annular spaces**

### Advantages

An **optimum protection of the environment** is guaranteed because of the factory **pre-laminated roll**. Dripping like with other classical resin **laminations does not occur**.

The system comes with all necessary accessories like eg. gloves. Safety glasses should be worn during processing. Skin contact has to be avoided.

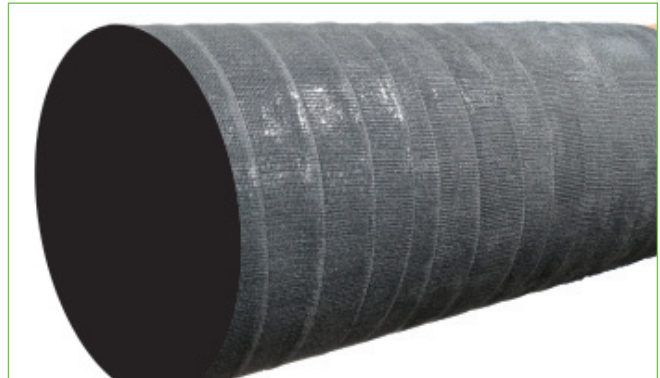

### Technical Data (typical numbers)

Thickness	-	approx. 0,7 mm
Compressive strength	DIN EN ISO 604	approx. 175 N/mm <sup>2</sup>
Color	-	black
Impact strength	DIN EN ISO 179	approx. 108 N/mm <sup>2</sup>
Impact toughness	DIN EN ISO 179	approx. 30 KJ/m <sup>2</sup>
Max. shortterm service temperature	-	max. 150°C
Hardeness Shore D	DIN 53505	approx. 70°

### Consumption table per joint – Experience values without tolerances

DN	Approx. length	Roll width
DN 80 (88.9 mm)	approx. 15 m	Roll width 100 mm
DN 100 (114.3 mm)	approx. 12 m	Roll width 150 mm
DN 150 (168.3 mm)	approx. 19 m	
DN 200 (219.1 mm)	approx. 22 m	
DN 250 (273.0 mm)	approx. 27 m	
DN 300 (323.9 mm)	approx. 34 m	
DN 400 (406.4 mm)	approx. 40 m	

The 4 pipes warranty only applies to faulty material. Checking the suitability of the product for the individual application is solely the responsibility of the user.

Description	Art.-No.
Roll 100 mm x 10 m	16711
Roll 150 mm x 10 m	16712
Adhesive tape transparent 50 mm x 66 m	16760
Stretch foil 0.5m x 300m, 20 µm thick	16765
Shore D measuring tool with drag indicator for hardness test of Pipecoat Plus	20304



Shore D  
measuring tool

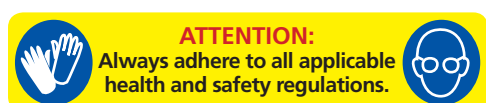

# Pipecoat Plus 4 pipes - FRP water-curing

## Application manual

The system comes with gloves. **Safety glasses should be worn during processing. Skin contact has to be avoided.**



1. Clean pipe surface, dry, degrease



2. Roughen with emery (corn 40-50)



3. Remove sanding residue and moisten surface

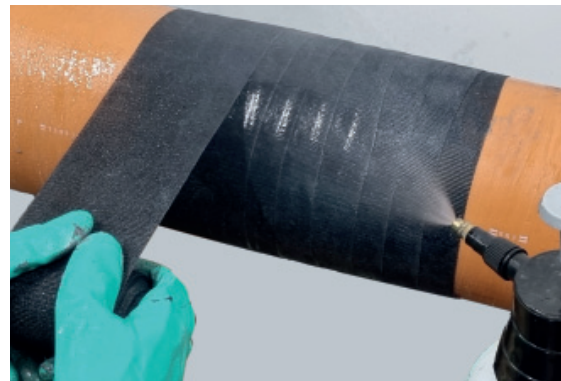

4. Wrap the Pipecoat Plus tape with minimum 1 x 75 % overlap (4 layers). **Spray water on the tape continuously during the wrapping process.** Time of processing 2-3 min., depending on temperature



5. Overwrap with clear foil or adhesive tape tightly



Application video



6. Check curing after approx. 60 minutes (approx. Shore D 70°±)

## Remarks

- For coating of pipes and corrosion-protection systems for trenchless applications the valid **DVGW-rules have to be considered**
- **A processing temperature +5°C up to 25°C is ideal**
- Always adhere to all applicable health and safety regulations (REACH restrictions for DIISOCYANATE)
- The material **must be fully cured before pipe is pulled in**

For a partial coating, e.g. welded joints the wrapping should overlap the protecting area in front and back with minimum

200 mm and the wrapping has to be applied as flat to the surface as possible to avoid any harsh edges.

The 4 pipes warranty only applies to faulty material. **Checking the suitability of the product for the individual application is solely the responsibility of the user.**





# Rock Shield Fleece 4 pipes



### Application

- High quality mechanical pipe protection
- Alternative for sand bedding e.g. on a slope
- On top of corrosion protection coatings e.g. petrolatum tapes
- Separation between pipe and ground when pipes are moving
- Separation of gravel and ground at site entry areas
- Base e.g. for tanks with foil coverage

### Installation

With adhesive tape or welding with soft propane gas flame.



### Technical data

Technical data	
Tolerance	± 10 %
Colour	colourful
Material	polypropylene/PES Thread reinforced
Weight per m <sup>2</sup>	1000g/m <sup>2</sup>
Thickness	8.5 mm ±
Impact strength	5000N ±
Chemical resistance	well
Permeable to water	suitable for cathodic protection
Size standard	1 x 25 m
Special Size	0.5 up to 4.0 m





Pipeline Accessories

Pressio®  
Wall Penetration Seals  
4 pipes

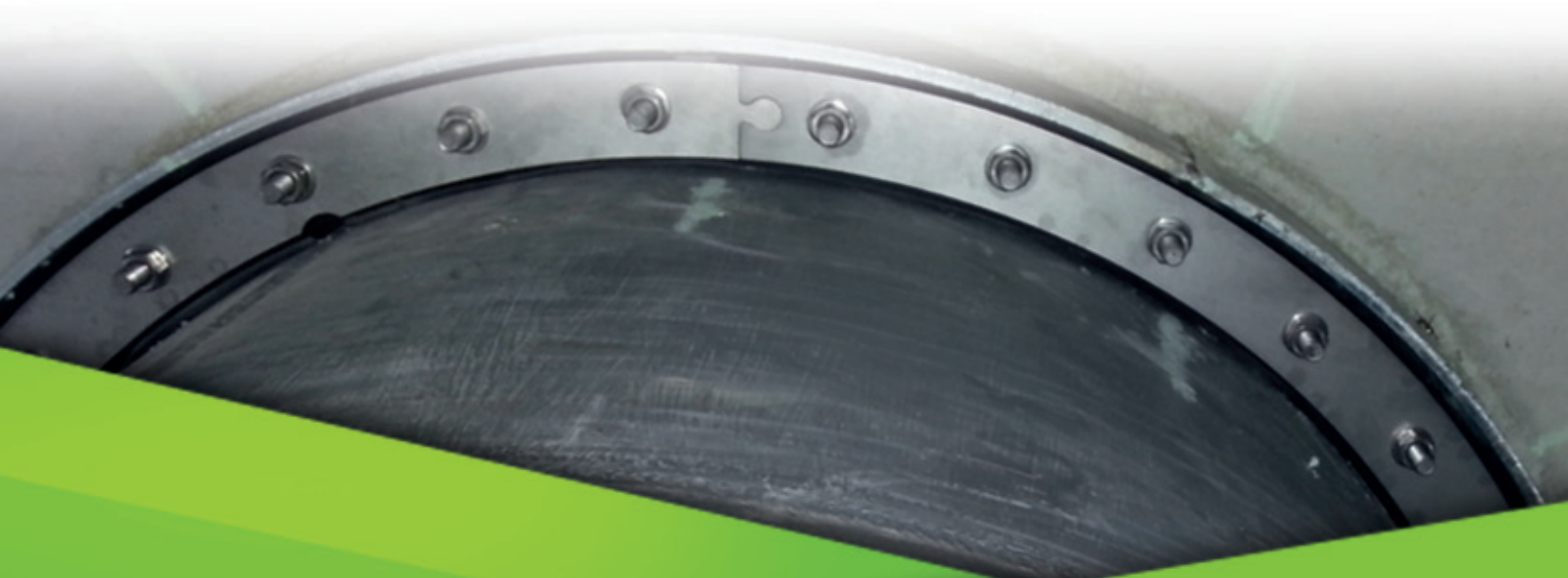

## The high performance pipeline wall penetration seal



Drinking water  
KTW/W270



MFPA  
tested



### Product information

**Pressio®-Rings Seals** work as high quality seals against high and low external water pressure in wall penetrations of pipes and cables.

**Pressio® Seals** are the most secure type for sealing wall penetrations for pipelines. This seal is basically tight against high and low external water pressure with pressure plates made of V2A stainless steel and extra soft rubber.

### Usage

**Gas and water tight closure** between carrier and casing pipe or core hole with a 40 mm thick rubber element (alternatively with two 40 mm rubber elements) which is compressed between 2 steel discs.

### Approval and test

- Pressure tight up to 5.0 bar\*
- Drinking water quality acc. to DVGW W270, Elastomer Guideline of UBA/KTW
- Radon tight

\*from 3 bar on, the seal has to be secured to prevent movement.

### Advantages

- fast mounting
- can be produced individually according to customer requirements
- usable at various building and plant applications
- pressure plates are made of stainless steel
- suitable for applications with high or low external water pressure
- Special elastomers possible, e.g. potable water EPDM or nitrile for gas or oil resistance

### Please note:

- Core bore should be coated with epoxy to protect the concrete and smoothen any possible cavities/grooves
- For retrofit installation a split Pressio® Seal is available
- Pipes have to be centered and supported
- Pressio® wall penetration seals do not provide any kind of pipe bedding or anchor point

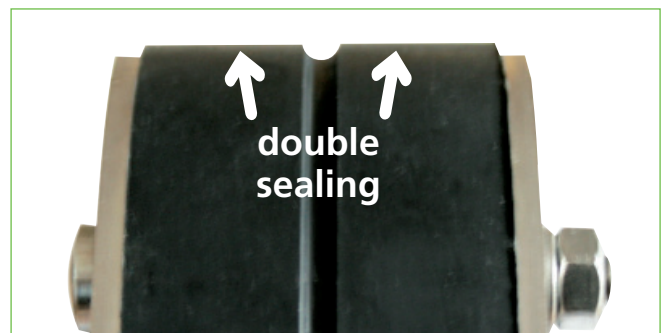

# Pressio®-Rings Type FW wall penetration seals 4 pipes

Preinsulated pipe wall penetration seal 2x40 mm  
Special design for district heating and cooling pipes

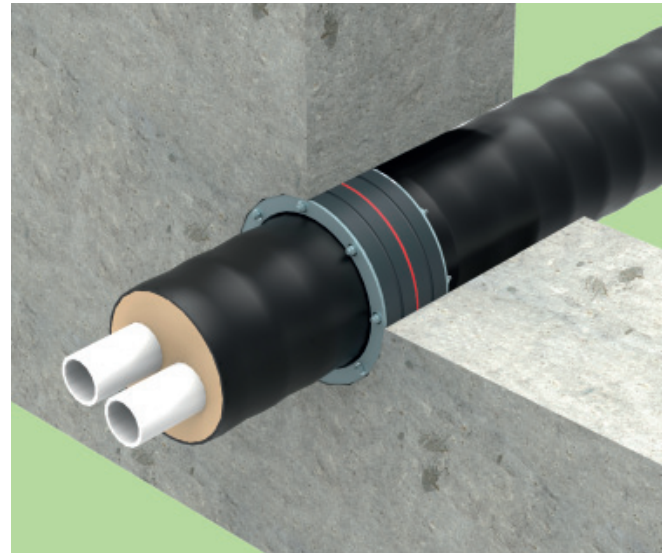

## Product information

Pressio®-Rings Type FW wall penetration seals are engineered for flexible and PE-jacket preinsulated pipe systems.

- Available in special preinsulated pipe dimensions in 1x40 mm and 2x40 mm version
- Special version with integrated cable feedthrough for monitoring and fiber optic systems
- Extra soft rubber allows **low tightening torque** with low danger of pipe deformation
- Special dimensions consider the pipe tolerances of the EN 253 and e.g. the ovalities of flexible pipes
- MFPA certified up to 5 bar pressure
- Individual dimensions possible
- Facilitates minimal pipe movement and angling

## Please note:

- Core hole should be coated with epoxy to protect the concrete and smoothen any possible cavities/grooves
- For retrofit installation a split Pressio® Seal is available
- Pipes have to be centered and supported
- Pressio® wall penetration seals do not provide any kind of pipe bedding or anchor point



**Pressio®-Rings 2 x 40 mm  
Rubber with 2 x 16 mm  
extra holes including  
reducing inserts and  
blind plugs**





**Pressio®-Rings 2 x 40 mm  
Rubber with 4 x 16 mm  
extra holes including  
reducing inserts and  
blind plugs**



# Pressio®-Rings wall penetration seals 4 pipes



Pressio® seals are designed to withstand high external water pressure

			Standard	Split version	District heating
Standard dimensions					
Core hole/ wall sleeve	Carrier pipe OD in mm		Stainless steel pressure plates bolts V2A Rubber size 1 x 40 mm Rubber: EPDM	Stainless steel pressure plates, <i>split</i> Version, bolts V2A Rubber size 1 x 40 mm Rubber: EPDM	Stainless steel pressure plates bolts V2A <i>Rubber size 2x40 mm</i> Rubber: EPDM
	mm	min.    max.	Art.-No.	Art.-No.	Art.-No.
50	6	12	10500	10600	-
70	10	22	10505	10605	-
70	24	32	10506	10606	*
70	32	41	10507	10607	*
80	20	28	10510	10610	*
80	28	32	10514	10614	*
80	32	40	10511	10611	*
80	40	50	10512	10612	-
100	15	22	10515	10615	-
100	20	28	10516	10616	*
100	25	32	10517	10617	*
100	32	40	10518	10618	*
100	36	44	10519	10619	*
100	41	51	10489	*	*
100	46	56	10520	10620	*
100	55	65	10521	10621	*
125	35	40	10523	10623	-
125	45	50	10524	10624	-
125	55	64	10525	10625	10702
125	61	70	10526	10626	10700
125	70	78	10527	10627	10701
150	35	40	10529	10629	*
150	46	54	10530	10630	10703
150	56	66	10531	10631	10704
150	69	78	10532	10632	10705
150	79	91	10533	10633	10708
150	85	94	10534	10634	10706
150	90	97	10536	10636	10745
150	98	110	10535	10635	10707
150	110	114.3	10537	10637	10762
187**	69	78	01563	01663	10763
187**	88	103	01564	01664	10764
187**	108	115	01565	01665	10765
187**	119	128	01566	01666	10766
187**	135	144	01567	01667	10767
200	88	103	10540	10640	10709
200	108	115	10541	10641	10710
200	116	126	10542	10642	10713
200	119	128	10543	10643	10711
200	125	135	10547	10647	10760
200	132	141	10544	10644	*
200	135	144	10545	10645	10712
200	140	150	10548	*	10761
200	150	160	10546	10646	10714

\*Available on request / Pressio® Individual special version up to DN 3000 on request

\*\*made for KG/KG2000 casing pipes

# Pressio®-Rings wall penetration seals 4 pipes



Pressio® seals are designed to withstand high external water pressure



Standard dimensions			Standard	Split version	District heating
				 	
Core hole/ wall sleeve	Carrier pipe OD in mm		Stainless steel pressure plates Bolts V2A Rubber size 1 x 40 mm Rubber: EPDM	Stainless steel pressure plates, <i>split</i> Version, bolts V2A Rubber size 1 x 40 mm Rubber: EPDM	Stainless steel pressure plates bolts V2A <i>Rubber size 2x40 mm</i> Rubber: EPDM
	mm	min.	max.	Art.-No.	Art.-No.
250	135	144	10550	10650	10715
250	140	149	10551	10651	10716
250	150	159	10552	10652	10717
250	156	165	10553	10653	10718
250	165	175	10554	10654	10721
250	174	181	10555	10655	10719
250	178	187	10556	10656	10720
250	197	202	10557	10657	10722
250	204	210	10558	10658	10723
300	178	187	10565	10665	10725
300	193	204	10566	10666	10726
300	198	207	10567	10667	10727
300	218	226	10568	10668	10728
300	224	233	10564	10664	10724
300	242	251	10569	10669	10729
350	224	233	10570	10670	10730
350	233	243	10574	10674	10759
350	249	258	10571	10671	10731
350	270	282	10572	10672	10732
350	279	288	10573	10673	10733
400	270	280	10575	10675	10734
400	279	288	10576	10676	10735
400	304	313	10577	10677	10736
400	314	323	10578	10678	10737
400	320	330	10579	10679	10738
500	354	364	01582	01682	10750
500	392	402	01583	01683	10752
500	400	412	01584	01684	10751
500	421	431	01585	01685	*
600	450	464	01588	01688	10755
600	494	504	01589	01689	*
600	500	515	01590	01690	10756
600	524	534	01591	01691	*

\*Available on request/ Pressio® Individual special version up to DN 3000 on request

# Pressio®-Rings wall penetration seals 4 pipes



Pressio® seals are designed to withstand high external water pressure



			V4A / 1.4571	Drinking water	Blind
Standard dimensions					
Core hole/ wall sleeve	Carrier pipe OD in mm		Stainless steel pressure plates and bolts V4A rubber: EPDM	Stainless steel pressure plates and bolts V2A, rubber: EPDM with KTW/W 270 approval**	Blind stainless steel pressure plates, bolts V2A rubber: EPDM
	mm	min.	max.	Art.-No.	Art.-No.
50	6	12	10300	10800	10585
70	10	22	10305	10805	10586
70	24	32	10306	10806	
70	32	41	10307	10807	
80	20	28	10310	10810	10587
80	32	40	10311	10811	
100	15	22	10315	10815	10596
100	20	28	10316	10816	
100	25	32	10317	10817	
100	32	40	10318	10818	
100	36	44	10319	10819	
100	46	56	10320	10820	
100	55	65	10321	10821	
125	55	64	10325	10825	
125	61	70	10326	10826	
125	70	78	10327	10827	
150	46	54	10330	10830	10598
150	56	66	10331	10831	
150	69	78	10332	10832	
150	79	91	10333	10833	
150	85	94	10334	10834	
150	98	110	10335	10835	
200	88	103	10340	10840	10591
200	108	115	10341	10841	
200	116	126	10342	10842	
200	119	128	10343	10843	
200	125	135	*	*	
200	132	141	10344	10844	
200	135	144	10345	10845	
200	140	150	*	*	
200	150	160	10346	10846	10592
250	135	144	10350	10850	
250	140	149	10351	10851	
250	150	159	10352	10852	
250	156	165	10353	10853	
250	165	175	10354	10854	
250	174	181	10355	10855	
250	178	187	10356	10856	
250	197	202	10357	10857	
250	204	210	10358	10858	

\* Available on request / Pressio® individual special version up to DN 3000 on request  
Rubber quality: NBR and KTW/W270 for Pressio seal with split version on request

\*\* according to DVGW W270, Elastomer Guideline of UBA / KTW  
**Attention: non-stock item**



Pressio® seals are designed to withstand high external water pressure

			V4A / 1.4571	Drinking water	Blind
Standard dimensions					
Core hole/ wall sleeve	Carrier pipe OD in mm		Stainless steel pressure plates and bolts V4A rubber: EPDM	Stainless steel pressure plates and bolts V2A, rubber: EPDM with KTW/W 270 approval**	Blind stainless steel pressure plates, bolts V2A rubber: EPDM
	mm	min.    max.	Art.-No.	Art.-No.	Art.-No.
300	178	187	10365	10865	10593
300	193	204	10366	10866	
300	198	207	10367	10867	
300	218	226	10368	10868	
350	224	233	10370	10870	10594
350	249	258	10371	10871	
350	270	282	10372	10872	
400	270	280	10375	10875	10595
400	279	288	10376	10876	
400	304	313	10377	10877	
400	314	323	10378	10878	
400	320	330	10379	10879	
500	354	364	01382	10882	*
500	392	402	01383	10883	
500	400	412	01384	10884	
500	421	431	01385	10885	
600	450	464	01388	10888	*
600	494	504	01389	10889	
600	500	515	01390	10890	
600	524	534	01391	10891	

\*Available on request / Pressio® individual special version up to DN 3000 on request  
Rubber quality: NBR and KTW/W270 for Pressio® seal with split version on request

\*\* according to DVGW W270, Elastomer Guideline of UBA / KTW  
**Attention: non-stock item**

# Pressio®-Rings wall penetration seals 4 pipes



Pressio®-Rings wall penetration seals specially designed for additional cable feedthroughs in the same wall penetration



Pressio®-Rings with 4 x 6 – 16 mm drill holes, incl. inserts and blind plug



Pressio®-Rings with 2 x 40 mm rubber with 4 x 6 - 16 mm drill holes, incl. inserts and blind plug





### Product Information

These Pressio® Rings wall penetration seals are manufactured with **up to four additional cable feedthrough holes**, making it possible to securely seal **cables, fibre-glass speedpipes** or thin pipes in the same wall penetration. These seals are absolutely tight in case of external water pressure, with pressure plates made of rust-free stainless steel V2A and extra soft elastomer. The inserts for the additional cable feedthrough holes fit inside each other in an onion-ring system that ensures a cable with any required diameter can be fed through easily and

securely. A blind plug can be left in any of the unused cable feedthrough holes in the seal.

### Please note:

- Core holes should be coated with epoxy resin to protect the concrete and smooth over any possible cavities or grooves
- All carrier pipes have to be supported
- Pressio® wall penetration seals do not provide any kind of pipe bedding or anchor point.

*Sealing range cable outlet 8 - 10 mm with insert 14 - 16 mm without insert			Pressio®-Rings with 2 x 16 mm extra outlets incl. inserts and blind plugs* Rubber width 1 x 40 mm EPDM		Pressio®-Rings with 2 x 16 mm extra outlets incl. inserts and blind plugs* Rubber width 2 x 40 mm EPDM	
OD	Carrier pipe		Art-No.	Art-No.		
mm	min.	max.				
150	69	78	01500	01700		
150	85	94	01501	01701		
200	108	115	01502	01702		
200	119	128	01503	01703		
200	135	144	01504	01704		
250	156	165	01505	01705		
250	178	187	01506	01706		
300	193	204	01507	01707		
300	224	233	01508	01708		

* Sealing range cable outlet from 6 up to 16 mm			Pressio®-Rings with 4 x 16 mm extra outlets incl. inserts and blind plugs* Rubber width 1 x 40 mm EPDM		Pressio®-Rings with 4 x 16 mm extra outlets incl. inserts and blind plugs* Rubber width 2 x 40 mm EPDM	
OD	Carrier pipe		Art-No.	Art-No.		
mm	min.	max.				
250	156	165	01545	01745		
250	178	187	01546	01746		
300	193	204	01547	01747		
300	224	233	01548	01748		

# Pressio®-Rings BlackLine wall penetration seals 4 pipes



tight up to  
1.5 bar

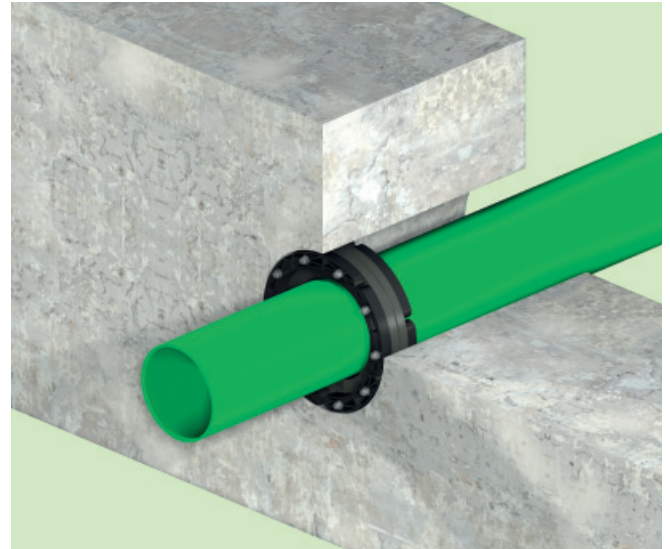

## Product information

Pressio® Rings BlackLine is our new series of sealing rings with pressure plates made from glass-fibre reinforced polyamide. They are used to seal wall penetrations for pipes and cables against high or low external water pressure. Pressio® Rings are the most secure way of sealing wall penetrations for pipelines.

## Usage

Gas and water tight closure between carrier and casing pipe or core hole with a 40 mm thick rubber element (alternatively with two 40 mm rubber elements) which is compressed between two polymer pressure plates.

## Approval and test

- pressure tight up to 1.5 bar
- tight against radon gas

## Advantages

- fast and easy installation
- pressure plates made from high strength polyamide PA6-30
- tight against high external water pressure
- Split seal can be used for retrofit application
- offset pressure plate placement allows very simple retrofit installation

Max torque tightening in Nm			
bolt size	height of pressure plate	for standard pipes	for thin walled plastic pipes
M6	18 mm	5 Nm	5 Nm
M8	22 mm	10 Nm	8 Nm

## Please note:

- Core holes should be coated with epoxy resin to protect the concrete and smooth over any possible cavities or grooves
- To carry out any subsequent installations, just remove one of the bolts next to the separation point to open the seal
- Carrier pipes have to be centred and supported
- Pressio® wall penetration seals do not provide any kind of pipe bedding or anchor point

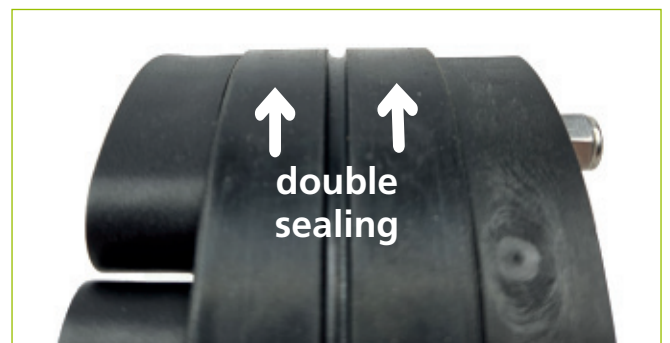

The 4 pipes warranty only applies to faulty material. Checking the suitability of the product for the individual application is solely the responsibility of the user.



# Pressio®-Rings BlackLine Type FW wall penetration seals 4 pipes



tight up to  
1.5 bar

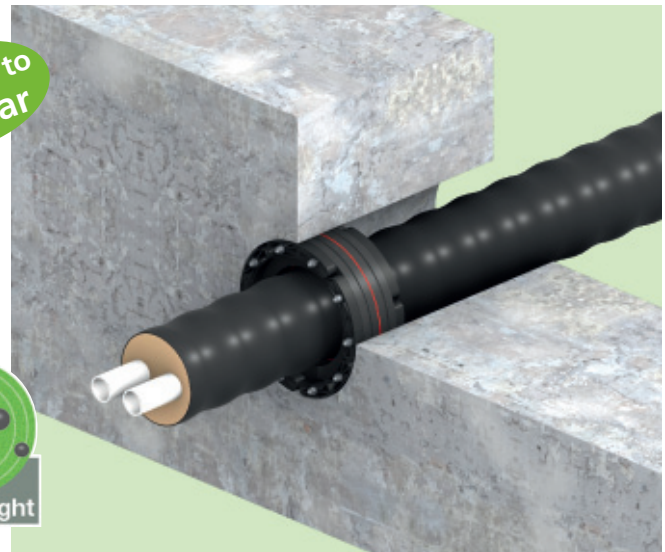

## Product information

Pressio®-Rings BlackLine type FW is our new series of sealing rings with pressure plates made from glass-fibre reinforced polyamide. They are **especially designed for flexible and PE-jacked preinsulated pipe systems for district heating** and are gastight and withstand also high external water pressure.

- Available in special preinsulated pipe dimensions in 1x 40 mm and 2x 40 mm version
- Extra soft rubber allows **low tightening torque** with low danger of pipe deformation
- Special dimensions consider the pipe tolerances of the EN 253 and e.g. the ovalities of flexible pipes
- IAF certified radon tightness
- Facilitates minimal pipe movement and angling

## Usage

**Gas- and water tight sealing** between carrier and casing pipe or core hole with two 40 mm rubber elements which are compressed between two polymer pressure plates.

## Approval and test

- Pressure tight up to 1.5 bar
- Tight against radon gas

## Advantages

- Fast and easy installation
- Pressure plates made from high strength polyamide PA6-30
- Gas- and water tight against high external water pressure
- **Split seal can be used for retrofit application**
- Offset pressure plate placement allows very simple retrofit installation

## Max torque tightening in Nm

bolt size	height of pressure plate	for standard pipes	for thin walled plastic pipes
M6	18 mm	5 Nm	5 Nm
M8	22 mm	10 Nm	8 Nm

## Please note:



- Core holes should be coated with epoxy resin to protect the concrete and smooth over any possible cavities or grooves
- To carry out any subsequent installations, just remove one of the bolts next to the separation point to open the seal
- Carrier pipes have to be centered and supported
- Pressio® wall penetration seals do not provide any kind of pipe bedding or anchor point

The 4 pipes warranty only applies to faulty material. Checking the suitability of the product for the individual application is solely the responsibility of the user.

# Pressio®-Rings BlackLine wall penetration seals 4 pipes



Pressio® seals are designed to withstand high external water pressure

			Split version	District heating	Blind
Standard dimensions					
Core hole/ wall sleeve	Carrier pipe OD in mm		Pressure plates PA6-30 split version bolts S316 Ti rubber 1 x 40 mm EPDM	Pressure plates PA6-30 split version bolts S316 Ti rubber 2 x 40 mm EPDM	Blind Pressure plates PA6-30 bolts S316 Ti rubber 1 x 40 mm EPDM
	mm	min.    max.	Art.-No.	Art.-No.	Art.-No.
80	20	28	55610	-	55587
80	28	32	55614	-	
80	32	40	55611	-	
80	40	50	55612	-	
100	20	28	55616	-	55588
100	25	32	55617	-	
100	32	40	55618	-	
100	36	44	55619	-	
100	46	56	55620	-	
100	55	65	55621	-	
125	55	64	55625	-	55589
125	61	70	55626	55700	
125	70	78	55627	55701	
150	46	54	55630	-	55590
150	56	66	55631	55704	
150	69	78	55632	55705	
150	79	91	55633	55708	
150	85	94	55634	55706	
150	90	97	55636	-	
150	98	110	55635	55707	
200	108	115	55641	55710	55591
200	116	126	55642	55713	
200	119	128	55643	55711	
200	132	141	55644	-	
200	135	144	55645	55712	
200	140	150	55648	55761	
200	150	160	55646	55714	
250	135	144	55650	55715	-
250	140	149	55651	55716	
250	150	159	55652	55717	
250	156	165	55653	55718	
250	165	175	55654	55721	
250	174	181	55655	55719	
250	178	187	55656	55720	
250	197	202	55657	55722	
250	204	210	55658	-	
300	178	187	55665	55725	
300	193	204	55666	55726	
300	198	207	55667	55727	
300	218	226	55668	55728	
300	224	233	55664	55724	
300	242	251	55669	55729	
350	249	258	55671	55731	-
350	270	282	55672	-	

## Your custom-made Pressio® wall penetration seal



### Product information

Pressio® Individual Seals are engineered and custom-made at 4 pipes to solve individual problems on site.

### Production options

- Multiple seals
- Oval/square outside
- Not centered
- Split or closed possible
- Dimensions up to DN 3000 possible
- Standard elastomer EPDM
- Special elastomers available (NBR, Viton, Silicone etc.)  
for e.g.
  - high temperatures
  - Chemicals
  - Oils/natural gas
  - potable water etc.
- Width 1x40 mm or 2x40 mm
- Pressure plates in various stainless steel qualities available
- To optimise production and functioning, we need your input.  
Please refer to the template on the next page and consider all details.

### Attention: fast delivery!

Express production is available at a premium.

### Please note:

- Core bore should be coated with epoxy to protect the concrete and smoothen any possible cavities/grooves
- For retrofit installation a split Pressio® Seal is available
- Pipes have to be centered and supported
- Pressio® wall penetration seals do not provide any kind of pipe bedding or anchor point

The 4 pipes warranty only applies to faulty material. Checking the suitability of the product for the individual application is solely the responsibility of the user.



## Example of a Template

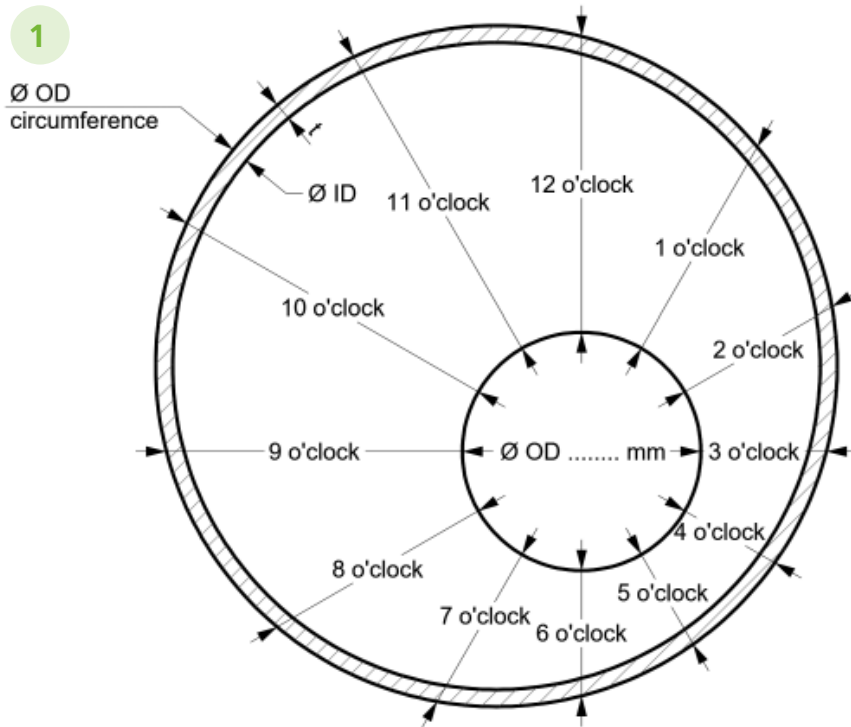

### Guideline technical input:

- Rubber
  - 1 x 40 mm
  - 2 x 40 mm
- Elastomer
  - EPDM
  - Nitrile
  - Viton
  - EPDM-KTW (drinking water)
  - Silicone
- Pressure plates
  - V2A
  - V4A / 1.4571
  - Steel spec.
- Dimension
  - split
  - closed
  - oversize flange
- Kind of pipe
- Tolerances
- Crane eyelet
- Handles

Please provide your original measured sizes so 4 pipes can design your seal with the correct cutting dimensions.

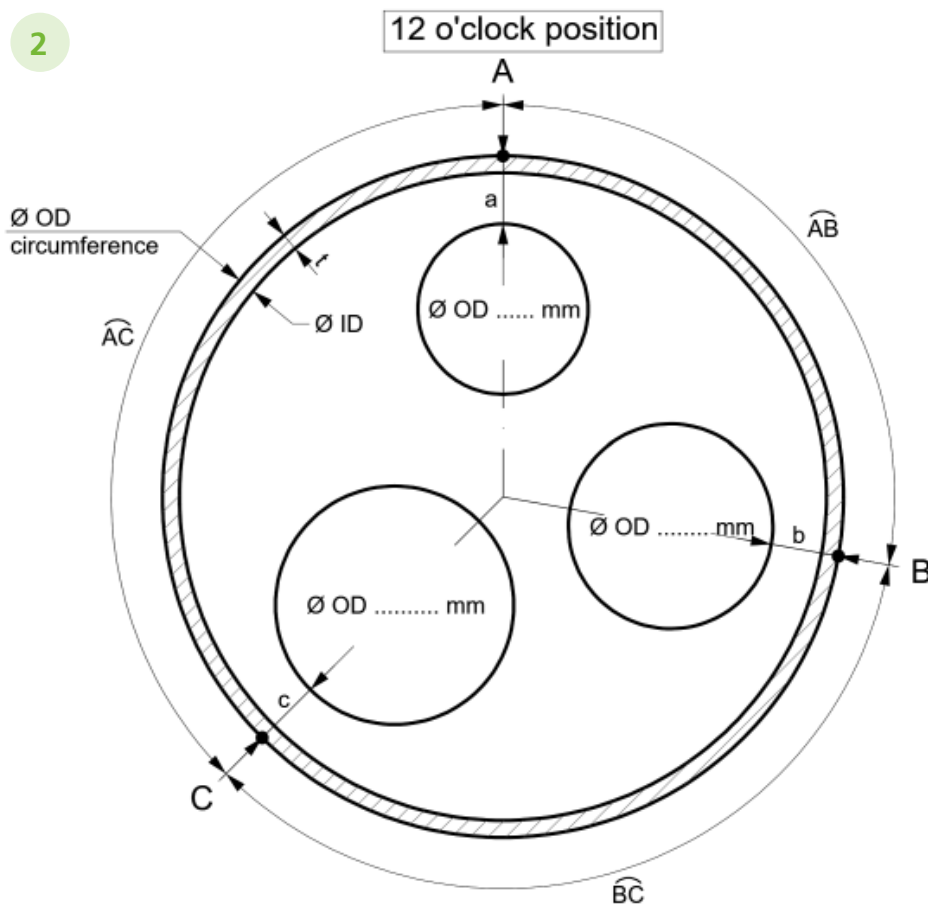

# Pressio® wall penetration seals 4 pipes

Character	Pressio® Seal Standard EPDM	Pressio® Seal for drinking water	Pressio® Seal for preinsulated pipes	Pressio® Seal BlackLine EPDM	Pressio® Individual
Core bore min/max	50 - 600 mm	50 - 2000 mm	125 - 600 mm	80 - 350 mm	40 - 3000 mm
Material pressure plate	V2A	V2A V4A on request	V2A	PA 6-30	Standard V2A, V4A / Epoxy coating on request
Rubber quality	EPDM	EPDM	EPDM	EPDM	EPDM EPDM with KTW/W 270* NBR (Nitrile) Silicone
Temperature	-30°C up to +120°C	-30°C up to +120°C	-30°C up to +120°C	-30°C up to +80°C	EPDM -30°C up to + 120°C NBR -30°C up to + 70°C Silicone -55°C bis + 200°C
Pressure rating	3.0 bar. held in place up to 5.0 bar	3.0 bar. held in place up to 5.0 bar	3.0 bar. held in place up to 5.0 bar	1.5 bar	1.5 bar**
Rubber thickness***	40 mm	40 mm	80 mm	40 mm / 80 mm	up to core hole 800 mm 1 x 40 mm rubber for core hole 800 mm and larger: 2 x 40 mm rubber
Rubber durometer, Shore A	45 ± 5	55 ± 5	45 ± 5	45 ± 5	Standard EPDM, EPDM with KTW ELLW 270 and NBR 50 ± 5 Silicone 50 ± 5
UV-resistance	good	good	good	good	EPDM good NBR bad

Values for pressure rating at 23°C. At higher temperatures, a holding fixture has to be installed.

\* EPDM-KTW rubber tested accord. KTW drinking water test and W270.

\*\* For annular spaces >100 mm, the seal should be held in place by further accessories.

\*\*\* Tolerance ± 1 mm



Further Pressio seal types are also available on request.



Seal with  
fixed-loose  
flange



Holding fixture M6 and M8



Pressio® individual, split, potable water, non centric

# Installation guide

## Pressio®-Rings wall penetration seals 4 pipes

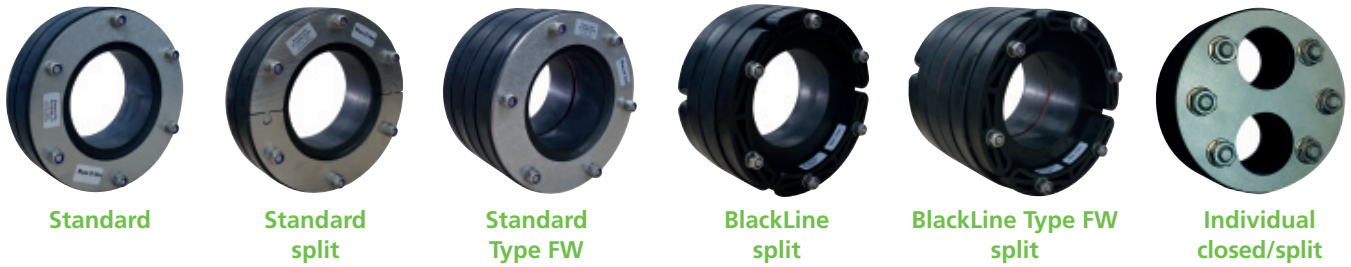

Standard

Standard split

Standard Type FW

BlackLine split

BlackLine Type FW split

Individual closed/split

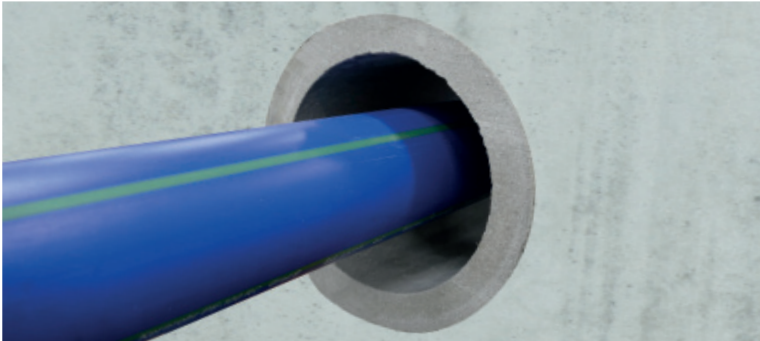

1. Clean the casing pipe/core bore and carrier pipe.
2. Check the casing pipe/core bore diameter and carrier pipe diameter against sealing range data written on the Pressio® seal.

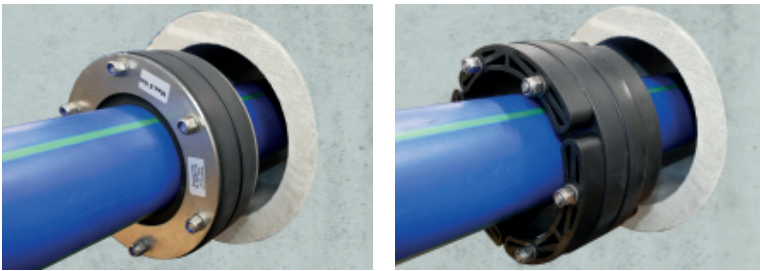

3. Push the seal on the carrier pipe.

**Attention:** Orientation of the nuts towards the inside of the building for later retightening.

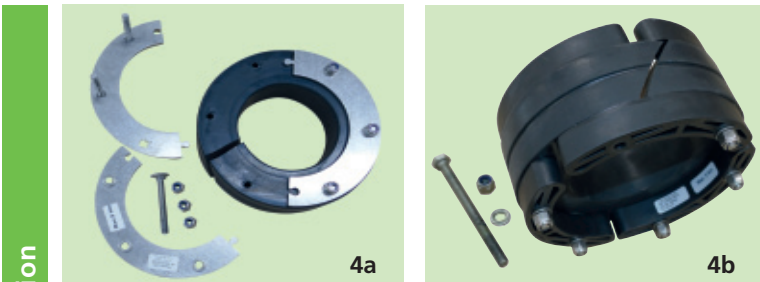

- 4a **Type Standard split:**  
Dismantle the seal at the split section.
- 4b **Type BlackLine split:**  
Remove **only one bolt** at the split section.

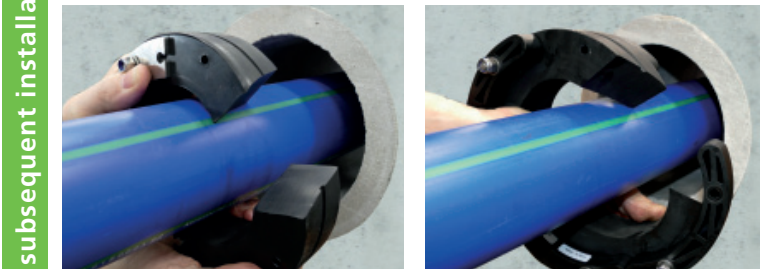

5. Fold the split seal around the carrier pipe.

**Attention:** Orientation of the nuts towards the inside of the building for later retightening.

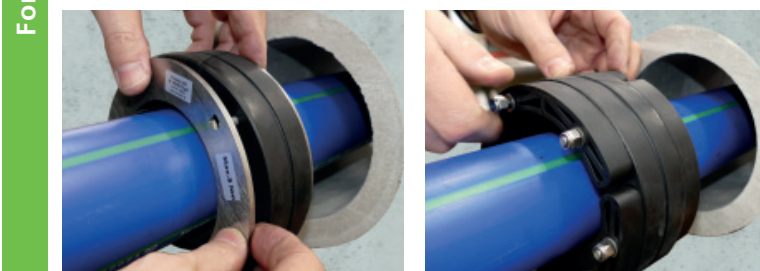

6. Reassemble the Pressio® seal on the carrier pipe.

For subsequent installation



# Installation guide

## Pressio®-Rings wall penetration seals 4 pipes

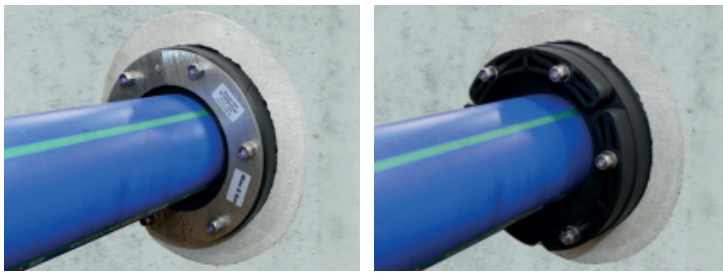

7. Push the Pressio® seal into the casing pipe or the core bore.



8. Insert the Pressio® seal into the wall and place it flush with the outside of the building.

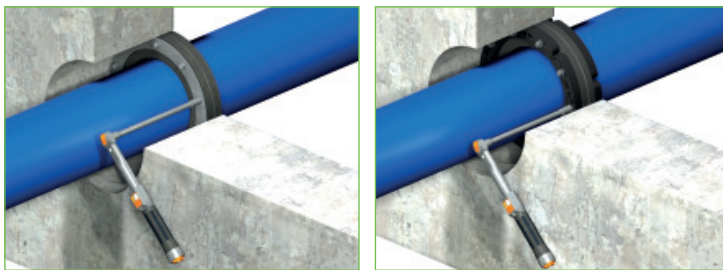

9. Use a torque wrench to tighten the nuts according to the below table.

**Attention:** Tighten the nuts in a clockwise pattern. Each nut is to be turned approx. three times. Several passes will be necessary until the torque value is achieved. If necessary, retighten the nuts after 2 hours until the torque is reached.

Max. tightening torques in Nm		
Bolt	Standard pipes	For thin-walled plastic pipes
M 6	5 Nm	5 Nm
M 8	10 Nm for Pressio® Standard, Standard split, Standard Type FW and BlackLine	8 Nm for Pressio® Standard, Standard split, Standard Type FW and BlackLine
	20 Nm for Pressio® Individual and Pressio® Type KTW/W270	15 Nm for Pressio® Individual
M 10	30 Nm	22 Nm
M 12	36 Nm	26 Nm

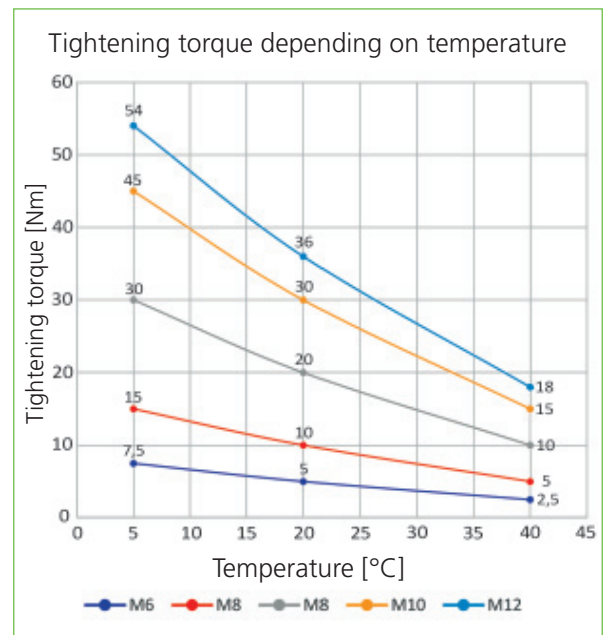

The 4 pipes warranty is limited to the replacement of faulty material. The usability of the product for the individual application is completely the responsibility of the user.



[Installation video](#)

# Pressio® Universal wall penetration seals 4 pipes with onion ring technology



closed standard



split snap  
in closure

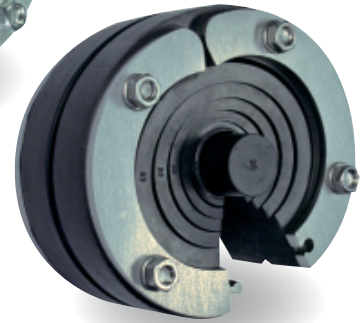

Pressio® Universal Seals can be used as a blind seal or single duct. Because of its soft rubber the Pressio Universal Seals are especially suitable for plastic pipes. The sealing range for the duct of a pipe/cable is stepped with rubber blades and therefore usable for various outside diameters.

Further Pressio® Universal Seal types (e.g. with extra-large flange) are also available on request.

## Advantages

- gas- and watertight
- 5 seals for 80% of the popular pipe sizes
- stock levels can be kept low
- fast mounting
- blade technology with large application range
- split version with snap-in closure
- double sealing
- extendable with extension rings 4 pipes

Pressio® Universal Seals do not provide any kind of pipe bedding or anchor point.

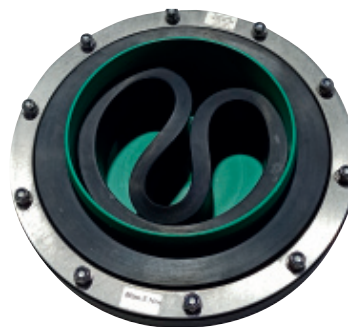

Pressio® Universal  
KB 250 mm and KB 300  
closed

## Technical data

Material pressure plate	V2A
Rubber thickness*	40 mm
Rubber quality	EPDM
Rubber grade, Shore A	45 ± 5
Temperature	-30°C up to +120°C

\* Tolerance ± 1 mm

# Pressio® Universal wall penetration seals 4 pipes with onion ring technology



Ø in mm	Product		Art.-No.
100		<p><b>Pressio® UNIVERSAL OD 100 mm, closed</b></p> <p>For carrier pipe OD: 18 up to 65 mm in 5 mm steps per ring</p> <p>Pressure rating as blind closure: 1.5 bar</p> <p>Pressure rating with carrier pipe: 1.5 bar</p> <p>Supplied incl. blind plug</p>	10490
100		<p><b>Pressio® UNIVERSAL OD 100 mm, closed with extra large flange</b></p> <p>For carrier pipe OD: 18 up to 65 mm in 5 mm steps per ring</p> <p>Pressure rating as blind closure: 1.5 bar</p> <p>Pressure rating with carrier pipe: 1.5 bar</p> <p>Supplied incl. blind plug</p>	10488
100		<p><b>Pressio® UNIVERSAL OD 100 mm, split</b></p> <p>For carrier pipe OD: 18 - 20, 25, 32, 40, 50, 63 mm</p> <p>Pressure rating as blind closure: 1.5 bar</p> <p>Pressure rating with carrier pipe: 1.5 bar</p> <p>Supplied incl. blind plug</p>	10499
150		<p><b>Pressio® UNIVERSAL OD 150 mm, closed</b></p> <p>For carrier pipe OD: 32, 40, 50, 60.3 up to 63 mm, 75 up to 76.1 mm, 88.9 up to 90 mm, 110 mm</p> <p>Pressure rating as blind closure: for low external water pressure</p> <p>Pressure rating with carrier pipe: 1.0 bar</p> <p>Supplied incl. blind plug</p>	10495
200		<p><b>Pressio® UNIVERSAL OD 200 mm, closed</b></p> <p>For carrier pipe OD: 110, 125 mm, 139.7 up to 140 mm, 160 mm</p> <p>Pressure rating as blind closure: for low external water pressure</p> <p>Pressure rating with carrier pipe: 1.0 bar</p> <p>Supplied incl. blind plug</p>	10493
250		<p><b>Pressio® UNIVERSAL OD 250 mm, closed</b></p> <p>For carrier pipe OD: 200 mm</p> <p>Reduction rings for carrier pipe OD: 160, 180 mm</p> <p>Pressure rating as blind closure: for low external water pressure</p> <p>Pressure rating with carrier pipe: 0.5 bar</p> <p>Supplied incl. reduction rings and PP blind plug</p>	10496
300		<p><b>Pressio® UNIVERSAL OD 300 mm, closed</b></p> <p>For carrier pipe OD: 250 mm</p> <p>Reduction rings for carrier pipe OD: 200, 225 mm</p> <p>Pressure rating as blind closure: for low external water pressure</p> <p>Pressure rating with carrier pipe: 0.5 bar</p> <p>Supplied incl. reduction rings and PP blind plug</p>	10497

The above-mentioned values refer to a pressure tightness rating at an operating temperature of 23°C. If the temperature is different, especially higher, a holding fixture has to be mounted.



# Pressio® Universal BlackLine wall penetration seals with onion ring technology



Ø in mm	Product		Art.-No.
80		<p><b>Pressio® UNIVERSAL BlackLine OD 80 mm, split</b></p> <p>For carrier pipe OD: 25 - 50 mm            Pressure rating as blind closure: 1.5 bar            Pressure rating with carrier pipe: 1.5 bar            Supplied incl. blind plug</p>	55487
100		<p><b>Pressio® UNIVERSAL BlackLine OD 100 mm, split</b></p> <p>For carrier pipe OD: 18-20, 25, 32, 40, 50, 63 mm            Pressure rating as blind closure: 1.5 bar            Pressure rating with carrier pipe: 1.5 bar            Supplied incl. blind plug</p>	55499
150		<p><b>Pressio® UNIVERSAL BlackLine OD 150 mm, split</b></p> <p>For carrier pipe OD: 32, 40, 50, 60.3 up to 63 mm, 75 up to 76.1 mm, 88.9 up to 90 mm, 110 mm            Pressure rating as blind closure: for low external water pressure            Pressure rating with carrier pipe: 0.5 bar            Supplied incl. blind plug</p>	55495
200		<p><b>Pressio® UNIVERSAL BlackLine OD 200 mm, split</b></p> <p>For carrier pipe OD: 110, 125, 139.7 up to 140 mm, 160 mm            Pressure rating as blind closure: for low external water pressure            Pressure rating with carrier pipe: 0.5 bar            Supplied incl. blind plug</p>	55493
250		<p><b>Pressio® UNIVERSAL BlackLine OD 250 mm, split</b></p> <p>For carrier pipe OD: 200 mm            incl. reduction rings for pipe OD: 160, 180 mm            Pressure rating as blind closure: for low external water pressure            Pressure rating with carrier pipe: 0.5 bar            Supplied incl. reduction rings (can be split) and PP blind plug</p>	55496
300		<p><b>Pressio® UNIVERSAL BlackLine OD 300 mm, split</b></p> <p>For carrier pipe OD: 250 mm            incl. reduction rings for pipe OD: 200, 225 mm            Pressure rating as blind closure: for low external water pressure            Pressure rating with carrier pipe: 0.5 bar            Supplied incl. reduction rings (can be split) and PP blind plug</p>	55497

The above-mentioned values refer to a pressure tightness rating at an operating temperature of 23°C. If the temperature is different, especially higher, a holding fixture has to be mounted.

# Installation guide

## Pressio® Universal wall penetration seals 4 pipes



Standard UNIVERSAL closed/seal



Standard UNIVERSAL (from OD 250) closed



BlackLine UNIVERSAL split



BlackLine UNIVERSAL (from OD 250) split

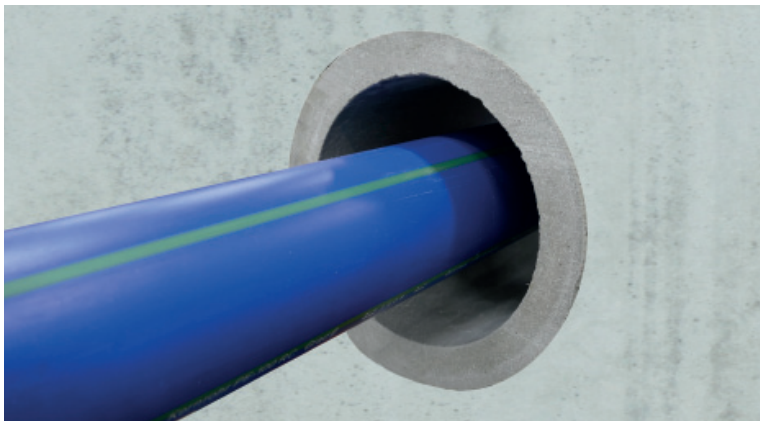

1. Clean the casing pipe/core bore and carrier pipe.
2. Check the casing pipe/core bore diameter and carrier pipe diameter against sealing range data written on the Pressio® seal.



3. Count the slats to be removed for the corresponding pipe diameter. If necessary, the seal can be split before subsequent installation.



4. To remove the slats, they are pressed through to the back and then cut off with a knife or pulled off by hand.

### Type UNIVERSAL (from OD 250 mm)

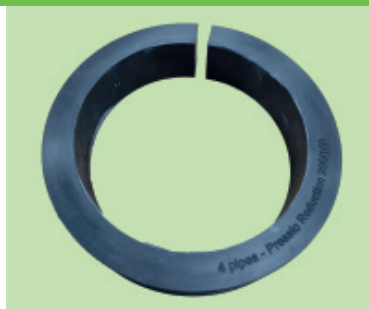

Select the suitable reduction ring for the corresponding diameter of the carrier pipe and insert it into the inner diameter of the seal. For subsequent installation (Type BlackLine), the reduction ring can be split on site using a knife.

# Installation guide

## Pressio® Universal wall penetration seals 4 pipes

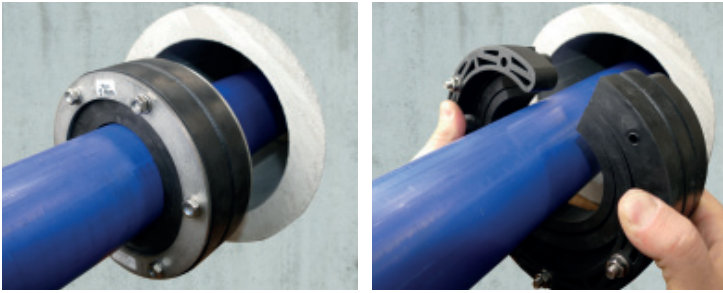

- Push the seal on the carrier pipe.  
For retrofitting reassemble the seal on the carrier pipe.

**Attention:**

Orientation of the nuts towards the inside of the building for later retightening.

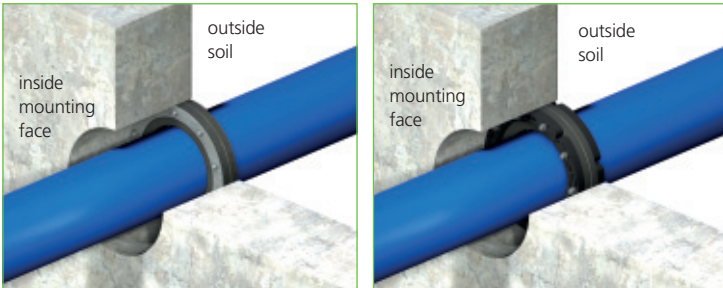

- Insert the Pressio® seal into the wall and place it flush with the outside of the building.



- Use a torque wrench to tighten the nuts according to the below table.

**Attention:**

Tighten the nuts in a clockwise pattern. Each nut is to be turned approx. three times. Several passes will be necessary until the torque value is achieved. If necessary, retighten the nuts after 2 hours until the torque is reached.

Max. tightening torques in Nm		
Bolt	Standard pipes	For thin-walled plastic pipes
M 6	5 Nm	5 Nm
M 8	10 Nm for Pressio® Standard, Standard split, Standard Type FW and BlackLine	8 Nm for Pressio® Standard, Standard split, Standard Type FW and BlackLine
	20 Nm for Pressio® Individual and Pressio® Type KTWW270	15 Nm for Pressio® Individual
M 10	30 Nm	22 Nm
M 12	36 Nm	26 Nm

The 4 pipes warranty is limited to the replacement of faulty material. The usability of the product for the individual application is completely the responsibility of the user.

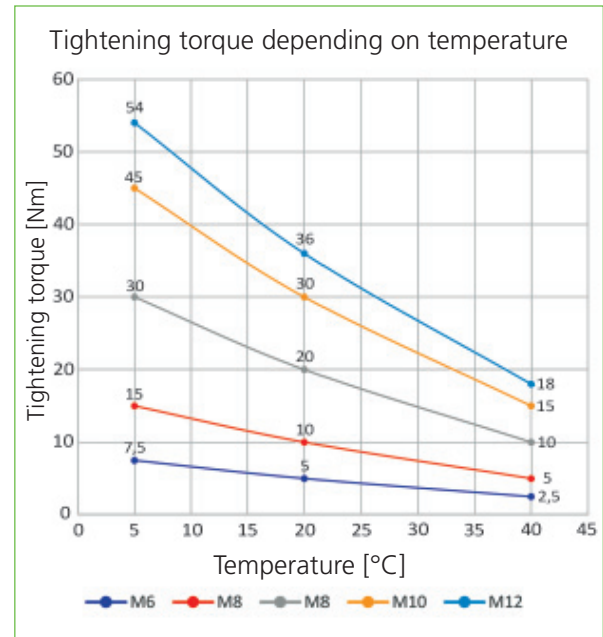

Installation video



## Pressio® Extension-Rings 4 pipes

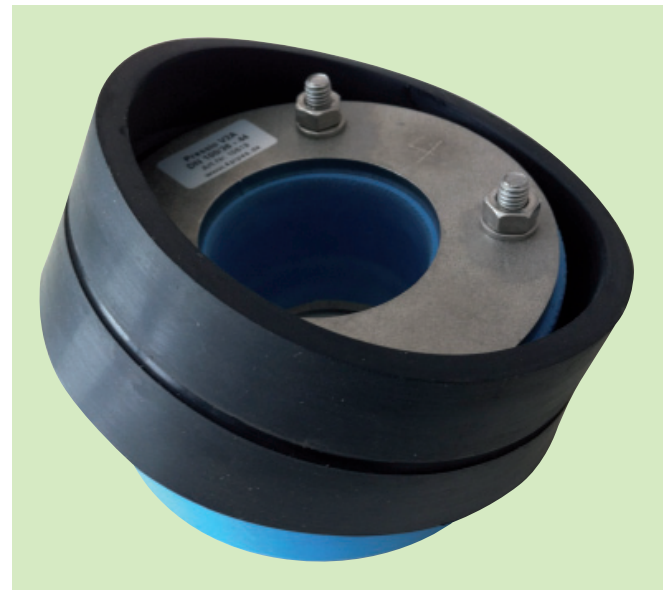

### Product information:

Pressio® Extension-Rings serve as an easy, save and cost-effective feature to **extend and adapt existing standard Pressio®-Wall-penetration seals 4 pipes to more unusual wall sleeve or core hole diameters.**

The outside diameter of a standard seal is built up with the extension rings. An individually cut seal is not always necessary any more.

This facilitates cost-effective stockkeeping, even for uncommon seal sizes.

Pressio® Extension-Rings are made of high quality, extra soft Shore A 43 ±5 EPDM, similar to the Pressio 4 pipes standard seals.

The **integrated groove and tongue** works acc. to the principles of a modular system, ensuring a secure hold of the ring. In this way, the Pressio® Extension Ring maintains the principle of the double-sealing wall penetration seal. Seals with the Extension Rings are tight against high external water pressure up to 1.5 bar.

### The application

of the Pressio®-Extension-Rings is very easy.

The ring with a corresponding inner diameter is **just pulled over a standard Pressio® seal. The groove and tongue system should snap in!**

Afterwards the complete **seal is mounted like a standard Pressio® seal according to the application manual.**

**Attention**, because of the groove and tongue system, the Extension-Rings are **only compatible to original Pressio®-Wall Penetration Seals 4 pipes with ONE groove!**

For Pressio® OD	Extension to	Description	Art.-No.
50 mm	58-60 mm	Pressio® - Extension 50 mm to 60 mm	08015
70 mm	75-79 mm	Pressio® - Extension 75 mm to 79 mm	08020
80 mm	85 mm	Pressio® - Extension 80 mm to 85 mm	08000
80 mm	90 mm	Pressio® - Extension 80 mm to 90 mm	08001
80 mm	93 mm	Pressio® - Extension 80 mm to 93 mm	08002
100 mm	103.6 mm	Pressio® - Extension 100 mm to 103.6 mm	08010
100 mm	110 mm	Pressio® - Extension 100 mm to 110 mm	08011
100 mm	118-120 mm	Pressio® - Extension 100 mm to 118-120 mm	08012
100 mm	125 mm	Pressio® - Extension 100 mm to 125 mm	08013
150 mm	158-160 mm	Pressio® - Extension 150 mm to 158-160 mm	08030

Do you sometimes have a number of non-standard core-drill holes, wall sleeve IDs or pipe IDs? Then get in touch with us – we will manufacture extension rings for your specific application.

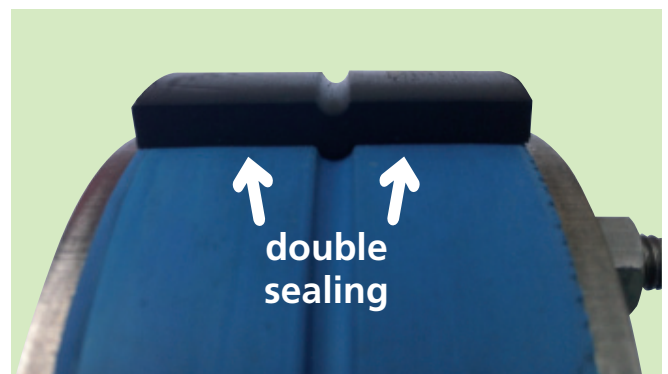



## Pressio® 4 cables® Wall Penetration Seals



# Pressio® 4 cables® wall penetration seals

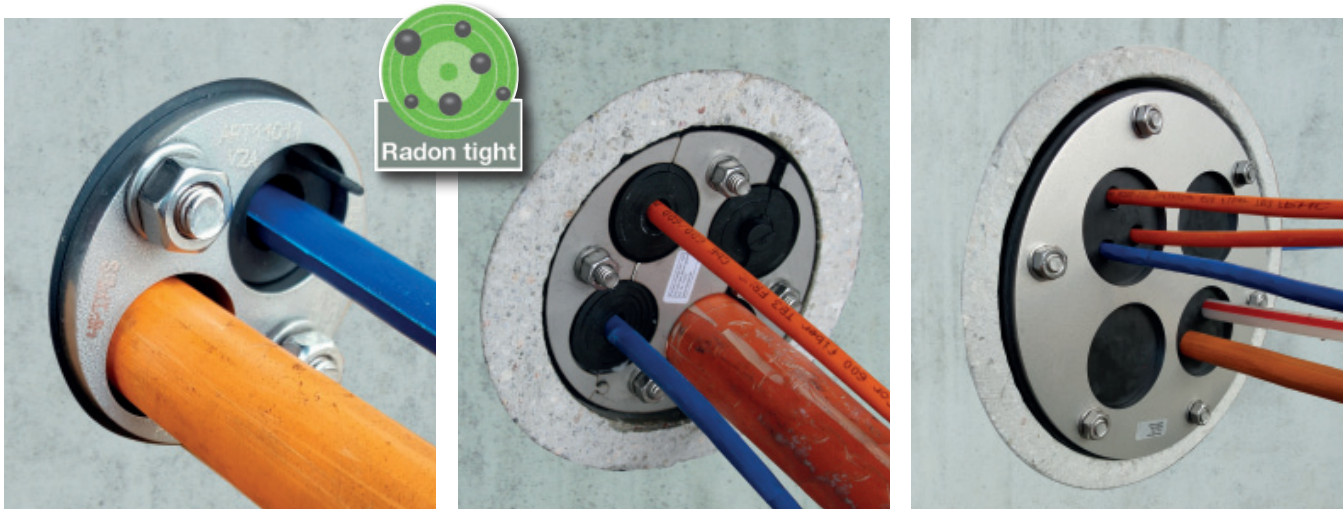

## Product information

The Pressio® Universal wall-penetration-seal 4 cables® is suitable as a **multiple seal** or a blind seal in wall-sleeves or core drilled holes.

The Pressio® Universal wall-penetration-seal 4 cables® is made as a secure seal protecting against high external water pressure for various **dimensions of cables or pipes** going through walls.

The sealing range of the **four single outlets** for cables or pipes is flexible for diameters between **6 and 32 mm\***. **Split rubber seals** in every individual outlet allow a flexible adjustment to the cable diameter and a retrofit application of the seal.

The **special „puzzle“ closure** avoids an opening of the seal during the application.

Individual cable and pipe penetrations of these diameters can be done within a very short time.

Multiple and single penetrations are possible. The seal is manufactured from high class EPDM rubber with stainless steel pressure plates made to withstand gas and high external water pressure. The rubber is especially soft (Shore A 45 ± 5) and elastic.

The pressure plates of the seal are **split** to enable subsequent installation on a pre-installed pipe.

Pressio® Seals 4 cables® are available for core holes of 50, 70, 80, 100, 125, 150 and 200 mm.

The cut **plugs are in the seal** when supplied and can be compressed. A later use as a blind seal is therefore possible.

Wall sleeves made of fibre cement, plastic or steel are available for Pressio® Seals 4 cables®.

## Advantages

- Easy feedthrough for multiple cables / carrier pipes in one core hole
- **Onion-ring inserts** for cables diameters of 6-50 mm\*
- Split seal, quick and easy to apply with **snap-in** closure
- Reduces required stock level
- Safe, fast installation
- Rubber with **double sealing** surface outside
- Tight up to 1.5 bar of high external water pressure
- Extension rings can be used on the OD to enlarge the diameter for special casing-pipe IDs

\* see exact sealing ranges of the versions

Technical data	
Material pressure plate	V2A *
Bolts	V2A *
Nuts	V4A
Rubber thickness	40 mm
Rubber quality	EPDM 45 ±5 Shore A
Temperature resistance	-30°C to +120°C

\* other qualities on request

## Overview variants

4 cables® UNIVERSAL	4 cables® FIXED	4 cables® CUSTOM
Onion ring technology allows a seal for different cable diameters	Seal with common cable dimensions, drilled in, with blind plugs	Individual cable / pipe penetrations can be cut into the seals at short notice. Closed or split on request



Pressio® 4 cables® UNIVERSAL - Onion ring technology		
Ø in mm	Product	Art.-No.
50	 <p><b>Pressio® 4 cables® UNIVERSAL OD 50 mm / 2x 6-16 mm, closed</b></p> <p>Pressure rating: 1.5 bar</p> <p>Supplied incl. blind plugs</p>	11011
100	 <p><b>Pressio® 4 cables® UNIVERSAL OD 100 mm / 18-65 mm, closed</b></p> <p>Possible cables-Ø: 18 up to 65 mm (in 5 mm steps per ring)</p> <p>Pressure rating: 1.5 bar</p> <p>Supplied incl. blind plug</p>	10490
100	 <p><b>Pressio® 4 cables® UNIVERSAL OD 100 mm / 18-20, 25, 32, 40, 50, 63 mm, split</b></p> <p>Pressure rating: 1.5 bar</p> <p>Supplied incl. blind plug</p>	10499
100	 <p><b>Pressio® 4 cables® UNIVERSAL OD 100 mm / 4x 6-30 mm, split, EPDM</b></p> <p>ID slats: 4x 6, 10, 14, 18, 22, 26, 30 mm (sealing range from 3.5 mm upward)</p> <p>Pressure rating: 1.0 bar</p> <p>Supplied incl. 4 pcs. blind plugs</p>	11020
	<p><b>Identical in construction, rubber NBR</b></p>	11024
100	 <p><b>Pressio® 4 cables® UNIVERSAL OD 100 mm / 2x 6-32 mm, 2x 6-26 mm, split</b></p> <p>ID slats: 2x 6, 10, 14, 18, 22, 26, 30, <b>32 mm</b> 2x 6, 10, 14, 18, 22, <b>26 mm</b> (sealing range from 3.5 mm upward)</p> <p>Pressure rating: 1.0 bar</p> <p>Supplied incl. 4 pcs. blind plugs</p>	11021
100	 <p><b>Pressio® 4 cables® UNIVERSAL OD 100 mm / 25-50 mm, 2x 6-16 mm, closed</b></p> <p>ID slats: 25, 30, 35, 40, 45, 50 mm 2x 10, 16 mm (sealing range from 6 mm upward)</p> <p>Pressure rating: 1.0 bar</p> <p>Supplied incl. blind plugs</p>	11014

Pressio® 4 cables® UNIVERSAL - Onion ring technology			
Ø in mm	Product		Art.-No.
150	 	<p><b>Pressio® 4 cables® UNIVERSAL</b>  <b>OD 150 mm / 32, 40, 50, 63, 76, 90, 110 mm, closed</b></p> <p>Possible cables-Ø: 32, 40, 50, 60.3 up to 63 mm,  75 up to 76.1 mm,  88.9 up to 90 mm, 110 mm</p> <p>Pressure rating as  blind closure: for low external water pressure  Pressure rating with  cable/carrier pipe: 1.0 bar</p> <p>Supplied incl. blind plug</p>	10495
150		<p><b>Pressio® 4 cables® UNIVERSAL</b>  <b>OD 150 mm / 3x 25-50 mm, closed</b></p> <p>ID slats: each 25, 30, 35, 40, 45, 50 mm  (sealing range from 22 mm upward)</p> <p>Pressure rating: 1.0 bar</p> <p>Supplied incl. blind plugs</p>	11025
150		<p><b>Pressio® 4 cables® UNIVERSAL</b>  <b>OD 150 mm / 3x 25-50 mm, split</b></p> <p>ID slats: each 25, 30, 35, 40, 45, 50 mm  (sealing range from 22 mm upward)</p> <p>Pressure rating: 1.0 bar</p> <p>Supplied incl. blind plugs</p>	11026
150		<p><b>Pressio® 4 cables® UNIVERSAL</b>  <b>OD 150 mm / 7x 5-32 mm, split</b></p> <p>ID slats: each 5, 10, 15, 20, 25, 32 mm  (sealing range from 3 mm upward)</p> <p>Pressure rating: 1.0 bar</p> <p>Supplied incl. blind plugs</p>	11027
200	 	<p><b>Pressio® 4 cables® UNIVERSAL</b>  <b>OD 200 mm / 110, 125, 140, 160 mm, closed</b></p> <p>Possible cables-Ø: 110, 125 mm  139.7 up to 140 mm, 160 mm</p> <p>Pressure rating as  blind closure: for low external water pressure  Pressure rating with  cable/carrier pipe: 1.0 bar</p> <p>Supplied incl. blind plug</p>	10493
200		<p><b>Pressio® 4 cables® UNIVERSAL</b>  <b>OD 200 mm / 3x 25-50 mm, 4x 5-32 mm, split</b></p> <p>ID slats DN 50: each 25, 30, 35, 40, 45, 50 mm  (sealing range from 22 mm upward)</p> <p>ID slats DN 32: each 5, 10, 15, 20, 25, 30 mm  (sealing range from 3 mm upward)</p> <p>Pressure rating: 1.0 bar</p> <p>Supplied incl. blind plugs</p>	11028

# Installation guide

## Pressio® 4 cables® UNIVERSAL wall penetration seals

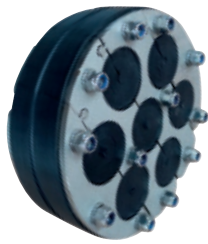

Pressio® 4 cables® UNIVERSAL closed/split



1. Clean the casing pipe/core bore and carrier pipe.
2. Check the casing pipe/core bore diameter and carrier pipe diameter against sealing range data written on the Pressio® seal.

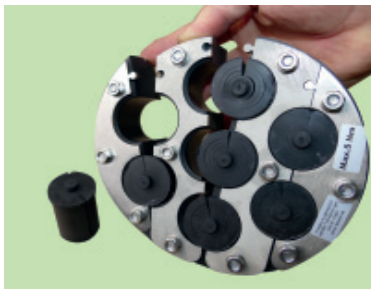

3. Count the slats to be removed for the corresponding pipe diameter.



4. To remove the slats, they are pressed through to the back and then cut off with a knife or pulled off by hand.



5. Insert carrier pipes or cables in the prepared feedthroughs.

**Attention:**

Orientation of the nuts towards the inside of the building for later retightening.



# Installation guide

## Pressio® 4 cables® UNIVERSAL wall penetration seals

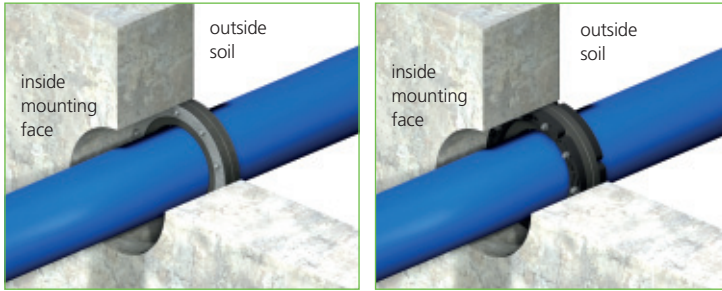

6. Insert the Pressio® seal into the wall and place it flush with the outside of the building.



7. Use a torque wrench to tighten the nuts according to the below table.

**Attention:**

Tighten the nuts in a clockwise pattern. Each nut is to be turned approx. three times. Several passes will be necessary until the torque value is achieved. If necessary, retighten the nuts after 2 hours until the torque is reached.

Max. tightening torques in Nm		
Bolt	Standard pipes	For thin-walled plastic pipes
M 6	5 Nm	5 Nm
M 8	10 Nm for Pressio® Standard, Standard split, Standard Type FW and BlackLine	8 Nm for Pressio® Standard, Standard split, Standard Type FW and BlackLine
	20 Nm for Pressio® Individual and Pressio® Type KTW/W270	15 Nm for Pressio® Individual
M 10	30 Nm	22 Nm
M 12	36 Nm	26 Nm

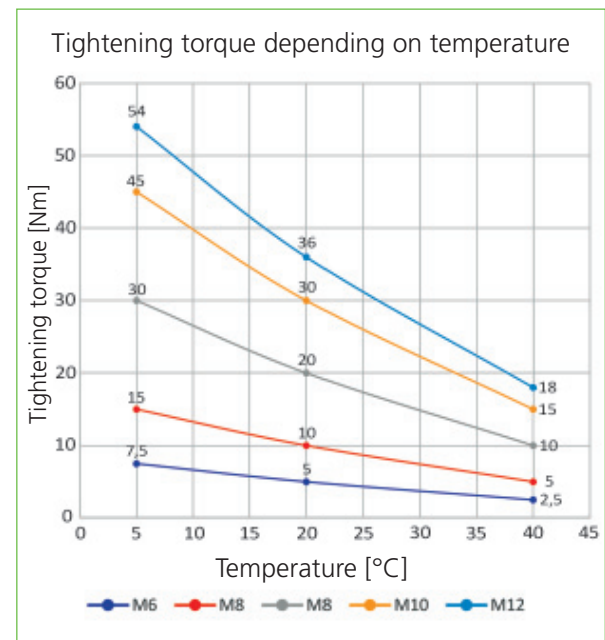

The 4 pipes warranty is limited to the replacement of faulty material. The usability of the product for the individual application is completely the responsibility of the user.



[Installation video](#)

Pressio® 4 cables® FIXED - fixed sizes			
Ø KB	Product	Art.-No.	
50		<p><b>Pressio® 4 cables® FIXED OD 50 mm / 2x 10-16 mm, split</b></p> <p>Pressure rating: 1.5 bar</p> <p>Supplied without blind plugs</p>	11012
100		<p><b>Pressio® 4 cables® FIXED OD 100 mm / Openings 8, 2x10, 12, 14, 16, 18 mm, closed or split</b></p> <p>Pressure rating: 1.5 bar</p> <p>Supplied incl. blind plugs</p>	11010
100		<p><b>Pressio® 4 cables® FIXED OD 100 mm / 32 mm and 2x 7 mm, closed</b></p> <p>Pressure rating: 1.5 bar</p> <p>Supplied incl. blind plugs</p>	11013
100		<p><b>Pressio® 4 cables® FIXED OD 100 mm / 2x 40 mm and 2x 32 mm, split</b></p> <p>*a suitable Pressio® Reduction Inlay 40 mm to 32 mm is optional available</p> <p>Pressure rating: 1.5 bar</p> <p>Supplied without blind plugs</p>	11017
100		<p><b>Pressio® 4 cables® FIXED OD 100 mm / 2x 40 mm and 2x 32 mm, split</b></p> <p>*a suitable Pressio® Reduction Inlay 40 mm to 32 mm is optional available</p> <p>Pressure rating: 1.5 bar</p> <p>For KG- and KG2000 pipe DN 100</p> <p>Supplied without blind plugs</p>	11018
		<p><b>Pressio®-Reduction Inlay 40 mm to 32 mm</b></p> <p>*suitable for Pressio® sealings with ID 40 mm</p>	08120
150		<p><b>Pressio® 4 cables® FIXED OD 150 mm / 3x 50 mm, closed</b></p> <p>Pressure rating: 1.0 bar</p> <p>Supplied without blind plugs</p>	11080
150		<p><b>Pressio® 4 cables® FIXED OD 150 mm / 3x 50 mm, split</b></p> <p>Pressure rating: 1.0 bar</p> <p>Supplied without blind plugs</p>	11081

Pressio® 4 cables® CUSTOM - drilled outlets			
Ø in mm	Product		Art.-No.
50	 <p>The seal will be custom drilled. Please order the seal with information about exact cable diameters and quantity of cables.</p>	<p><b>Pressio® 4 cables® CUSTOM OD 50 mm, closed or split</b> (Price incl. 2 outlets)</p> <p>ID-pressure plate: 22 mm Possible cables-Ø: 2 up to 19 mm Pressure rating: 1.5 bar</p> <p>Please specify when ordering: - closed or split - Cable / carrier pipe diameter</p>	11000
70		<p><b>Pressio® 4 cables® CUSTOM OD 70 mm, closed or split</b> (Price incl. 2 outlets)</p> <p>ID-pressure plate: 43 mm Possible cables-Ø: 2 up to 40 mm Pressure rating: 1.5 bar</p> <p>Please specify when ordering: - closed or split - Cable / carrier pipe diameter</p>	11005
80		<p><b>Pressio® 4 cables® CUSTOM OD 80 mm, closed or split</b> (Price incl. 2 outlets)</p> <p>ID-pressure plate: 43 mm Possible cables-Ø: 2 up to 40 mm Pressure rating: 1.5 bar</p> <p>Please specify when ordering: - closed or split - Cable / carrier pipe diameter</p>	11001
100		<p><b>Pressio® 4 cables® CUSTOM OD 100 mm, closed or split</b> (Price incl. 2 outlets)</p> <p>ID-pressure plate: 66 mm Possible cables-Ø: 2 up to 50 mm Pressure rating: 1.5 bar</p> <p>Please specify when ordering: - closed or split - Cable / carrier pipe diameter</p>	11002
125		<p><b>Pressio® 4 cables® CUSTOM OD 125 mm, closed or split</b> (Price incl. 2 outlets)</p> <p>ID-pressure plate: 82 mm Possible cables-Ø: 2 up to 63 mm Pressure rating: 1.5 bar</p> <p>Please specify when ordering: - closed or split - Cable / carrier pipe diameter</p>	11003
150	<p><b>Pressio® 4 cables® CUSTOM OD 150 mm, closed or split</b> (Price incl. 2 outlets)</p> <p>ID-pressure plate: 112 mm Possible cables-Ø: 2 up to 63 mm Pressure rating: 1.5 bar</p> <p>Please specify when ordering: - closed or split - Cable / carrier pipe diameter</p>	11004	

Example:  
Pressio® 4 cables® CUSTOM OD 100 mm,  
with 2 drilled outlet

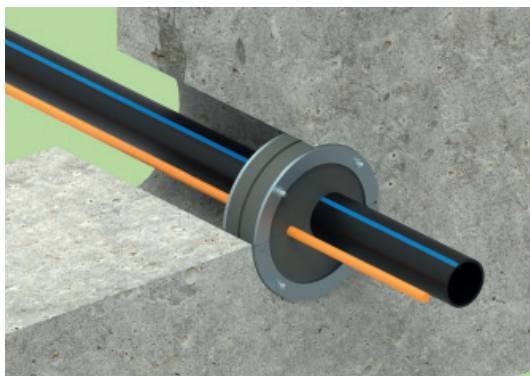

Pressio® 4 cables® CUSTOM installation example

The cut-out plugs remain in the seal and can be used as blind plugs.  
A later assignment of the blind plug is possible.



Pressio® 4 cables® CUSTOM - drilled outlets		
Ø in mm	Product	Art.-No.
200	  <p><b>Pressio® 4 cables® CUSTOM OD 200 mm, closed</b> (Price incl. 2 outlets)</p> <p>ID-pressure plate: 2x 56 mm, 2x 70 mm Possible cables-Ø: 2x 2 up to <b>50 mm</b> 2x 2 up to <b>63 mm</b> Pressure rating: 1.5 bar</p> <p>Please specify when ordering: - Cable / carrier pipe diameter</p>	11006
	each additional drilled outlet	11015

Pressio® 4 cables® FIXED BlackLine		
Ø in mm	Product	Art.-No.
100	 <p><b>Pressio® 4 cables® FIXED BlackLine OD 100 mm/ Outlets 8, 2x10, 12, 14, 16, 18 mm split</b></p> <p>Pressure rating: 1.5 bar Supplied incl. blind plugs</p>	55010

**Please note:**

- A core drilled hole can be coated with our **epoxy-resin (Art.-No. 13099)** to protect the concrete and smoothen over any holes or scratches.
- Cables/carrier pipes should be supported.
- **4 pipes lubricant (Art.-No. 09599)** helps sliding the seal over the cables and carrier pipes.



If necessary, leave the blind plug in the gasket

# Installation guide Pressio® 4 cables® FIXED and CUSTOM wall penetration seals



Standard 4 cables® FIXED  
closed/split  
without blind plugs



Standard 4 cables® FIXED und CUSTOM  
closed/split  
with blind plugs



BlackLine 4 cables® FIXED  
split  
with blind plugs



1. Clean the casing pipe/core bore and carrier pipe.
2. Check the casing pipe/core bore diameter and carrier pipe diameter against sealing range data written on the Pressio® seal.

## For subsequent installation - on-site splitting if possible



3a. Disassemble sealing completely



3b. If necessary, cut sealing rubber with a knife.

**Attention:** Splitting cut at the 12 o'clock position must correspond with the puzzle fastener.

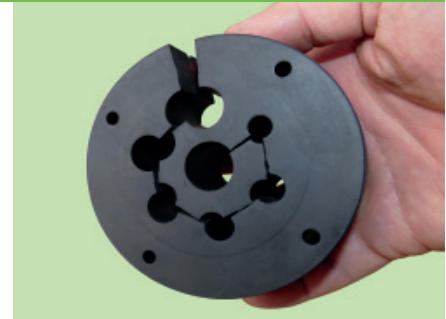

3c. Ready split sealing rubber

## Reassemble sealing afterwards



4a

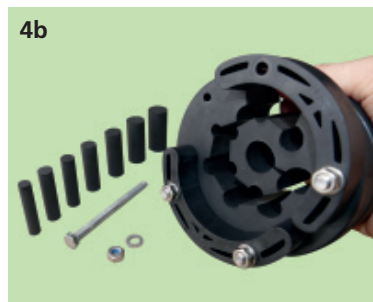

4b

### 4a. Type Standard split:

Open the seal at the intended location (Puzzle fastener)

### 4b. Type BlackLine split:

Remove only one bolt at the split section.

If present, remove all unused blind plugs.

# Installation guide Pressio® 4 cables® FIXED and CUSTOM wall penetration seals



5a. Insert carrier pipes or cables in the prepared feedthroughs.

5b. Type BlackLine split:  
Reassemble the seal on the carrier pipes/cables.

**Attention:**

Orientation of the nuts towards the inside of the building for later retightening.  
Reinsert blind plugs in unused openings.



6. Push the Pressio® seal into the casing pipe or the core bore.



7. Insert the Pressio® seal into the wall and place it flush with the outside of the building.



8. Use a torque wrench to tighten the nuts according to the below table.

**Attention:** Tighten the nuts in a clockwise pattern. Each nut is to be turned approx. three times. Several passes will be necessary until the torque value is achieved. If necessary, retighten the nuts after 2 hours until the torque is reached.

Max. tightening torques in Nm		
Bolt	Standard pipes	For thin-walled plastic pipes
M 6	5 Nm	5 Nm
M 8	10 Nm for Pressio® Standard, Standard split, Standard Type FW and BlackLine	8 Nm for Pressio® Standard, Standard split, Standard Type FW and BlackLine
	20 Nm for Pressio® Individual and Pressio® Type KTW/W270	15 Nm for Pressio® Individual
M 10	30 Nm	22 Nm
M 12	36 Nm	26 Nm

The 4 pipes warranty is limited to the replacement of faulty material. The usability of the product for the individual application is completely the responsibility of the user.

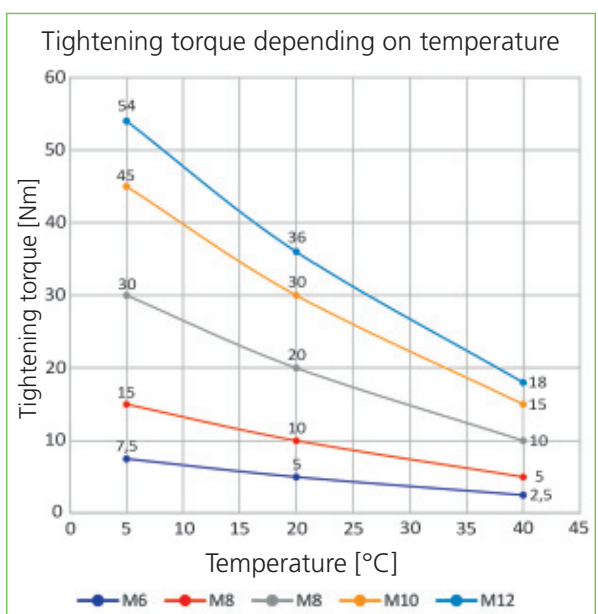





Pipeline Accessories

## Wall Penetration Sets 4 pipes

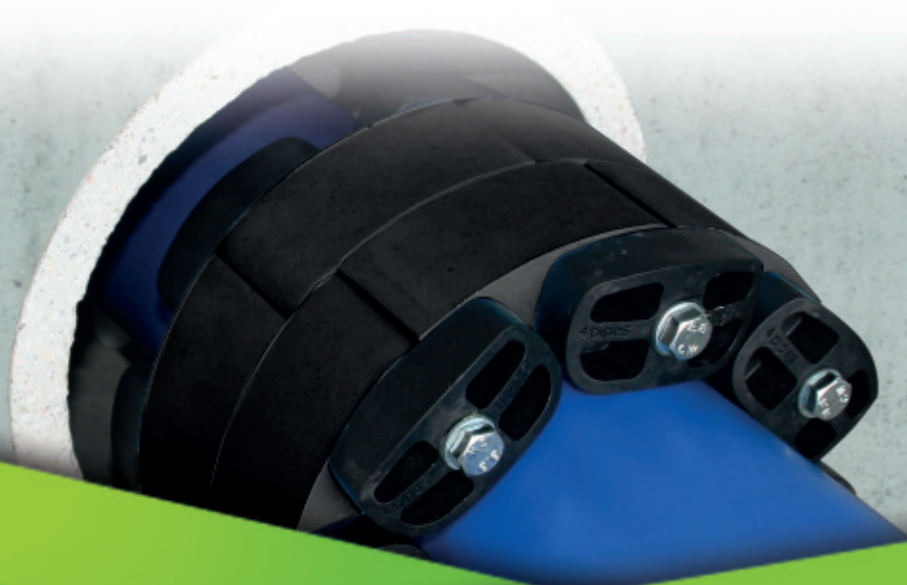
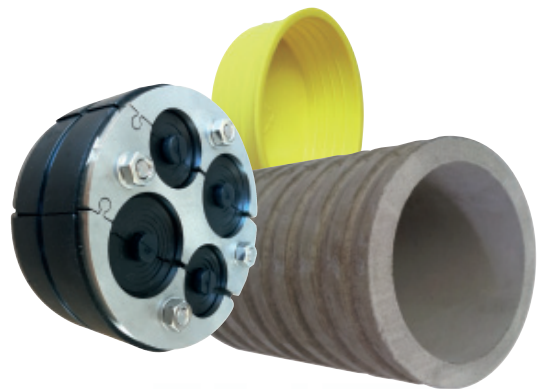

# Wall Penetration Sets 4 pipes

Wall penetration seal, wall sleeve and mounting caps supplied as complete kits.  
For easy and reliable wall penetration of service pipes and cables.

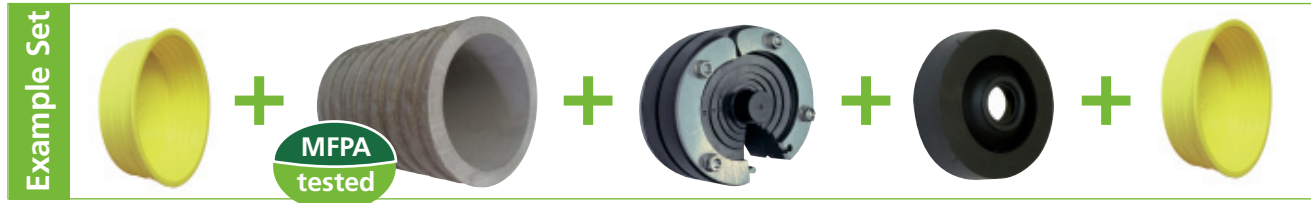

The proven wall-penetration system made of wall sleeve and 4 pipes Pressio® wall seals is now also available as a complete kit. In addition, there are two mounting caps to close the wall sleeve during the casting process.

An optimised seal to the pipe or cable is provided by one of the following versions of our 4 pipes Pressio® wall penetration seals.

Our PVC or fibre cement wall sleeves will shape a perfect wall opening. The sleeves provides a special surface on the outside with grooving to ensure the bond with the wall cement.

### Technical data and material properties

- of seals can be found on the individual technical datasheets
- Pressio®-Rings wall penetration seals 4 pipes
  - Wall penetration seals Pressio® 4 cables®
  - Pressio®-Elements wall penetration seals 4 pipes

Core hole ID	Pressio® Wall Penetration Seal	Rubber support ring	Wall sleeve	Moun-ting cap	Art.-No.
--------------	--------------------------------	---------------------	-------------	---------------	----------





#### Standard sets with PVC wall sleeve:

100 mm	2 pcs. - Pressio® Universal 18-65 mm (closed)	/	1 pc. - PVC	2 pcs.	28300
	1 pc. - Pressio® Universal 18-65 mm (closed)	1 pc.			28301
	2 pcs. - Pressio® Universal 18-65 mm (split)	/			28302
	1 pc. - Pressio® Universal 18-65 mm (split)	1 pc.			28303
	2 pcs. - Pressio® 4 cables® UNIVERSAL (split)	/			28312
	1 pc. - Pressio 4 cables UNIVERSAL (split)	1 pc.			28313
150 mm	7 pcs. Pressio® - Elements IL 310 S 316, EPDM	/			28320
200 mm	10 pcs. Pressio® - Elements IL 310 S 316, EPDM	/			28330

#### Standard sets with fibre cement wall sleeve:

100 mm	2 pcs. - Pressio® Universal 18-65 mm (closed)	/	1 pc. - fibre cement	2 pcs.	28350
	1 pc. - Pressio® Universal 18-65 mm (closed)	1 pc.			28351
	2 pcs. - Pressio® Universal 18-65 mm (split)	/			28352
	2 pcs. - Pressio® 4 cables® UNIVERSAL (split)	/			28353
	1 pc. - Pressio® 4 cables® UNIVERSAL (split)	1 pc.			28354
150 mm	7 pcs. Pressio® - Elements IL 310 S 316, EPDM	/			28360
200 mm	10 pcs. Pressio® - Elements IL 310 S 316, EPDM	/			28370

#### Components:

	Pressio® Universal 100 / 18-65 mm V2A closed version (with onion-ring technology)		Pressio®-Elements Wall Penetration Seal IL 310 S 316, EPDM, 50 ±5 Shore A Bolts V4A (7 or 10 elements) (105-114 mm or 155-164 mm)		Fibre Cement Wall Sleeve ID 100 / 150 / 200 mm Length 250 mm
	Pressio® Universal 100 / 18-65 mm V2A split version (with onion-ring technology)			Pressio® 4 cables® UNIVERSAL 100 / 2 x 6-32 mm, 2 x 6-25 mm V2A split version (with onion-ring technology)	
	Rubber Support Ring 100 / 32-40 mm				



Pipeline Accessories

## District Heating Baseplate Penetration 4 pipes





# District Heating Baseplate Penetration 4 pipes Complete Set



The Builder Complete Set contains the appropriate 4 pipes sealing:  
**Pressio®-Rings Type FW** with oversized flange for diameters of flexible preinsulated pipes.

The new district heating baseplate penetration 4 pipes has been developed for **direct concrete encasing into the baseplate**, for the feed-in and secure sealing of **flexible district heating pipes**.

The components can be mounted in just a few simple steps.

- **preassembled ready to use**
- guaranteed tightness to **withstand high external water pressure** up to 5 bar (MFPA tested) using the proven 4 pipes wall collar
- certified **radon tightness**
- solid positioning and easy adjustment in the pipe trench
- suitable for all common systems of flexible preinsulated pipes
- ready for connecting a KG2000- / KG-pipe at the construction site
- easy installation: position of connection sleeves and pipe bends guarantee an **optimum pipe feed**
- intelligent development of new construction areas

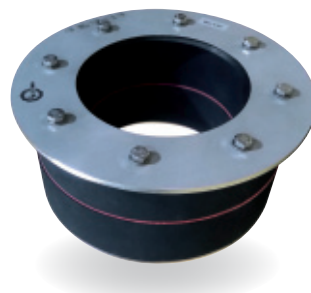
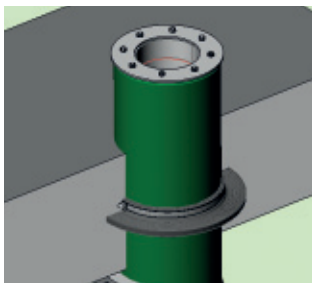

Flex pipe jacket OD	Minimum bending radius flex pipe						Resulting elbow radius (mm) of baseplate penetration set
	up to 0,9 m	1,0 m	1,1 m	1,2 m	1,3 m	1,4 m	
FW 90	800	800	1000	1000	1200	1200	
FW 110	800	1000	1000	1200	1200		
FW 125	800	1000	1000	1200	1200		
FW 140	800	1000	1000	1200	1200		

**NOTE:** By choosing the correct radius of the baseplate penetration the minimum bending radius of the flexpipe is always maintained.

# District Heating Baseplate Penetration 4 pipes Complete Set



Product		Description	Elbow radius		
			R=800 mm	R=1000 mm	R=1200 mm
			Art.-No.	Art.-No.	Art.-No.
single	Builder <b>basic set</b> 4 heating baseplate penetration single DN 200	Empty conduit system <b>without sealing</b>	09600	09659	09674
	Builder <b>complete set</b> 4 heating baseplate penetration single DN 200	for flexible pre-insulated pipe <b>OD 69-78 mm</b>	09605	09660	09675
	Builder <b>complete set</b> 4 heating baseplate penetration single DN 200	for flexible pre-insulated pipe <b>OD 88-103 mm</b>	09601	09661	09676
	Builder <b>complete set</b> 4 heating baseplate penetration single DN 200	for flexible pre-insulated pipe <b>OD 108-115 mm</b>	09602	09662	09677
	Builder <b>complete set</b> 4 heating baseplate penetration single DN 200	for flexible pre-insulated pipe <b>OD 119-128 mm</b>	09603	09663	09678
	Builder <b>complete set</b> 4 heating baseplate penetration single DN 200	for flexible pre-insulated pipe <b>OD 135-144 mm</b>	09604	09664	09679
double	Builder <b>basic set</b> 4 heating baseplate penetration <b>double</b> DN 200	Empty conduit system <b>without sealing</b>			
	Builder <b>complete set</b> 4 heating baseplate penetration <b>double</b> DN 200	for flexible pre-insulated pipes <b>2x OD 69-78 mm</b>	09615	09666	09685
	Builder <b>complete set</b> 4 heating baseplate penetration <b>double</b> DN 200	for flexible pre-insulated pipes <b>2x OD 88-103 mm</b>	09611	09667	09686
	Builder <b>complete set</b> 4 heating baseplate penetration <b>double</b> DN 200	for flexible pre-insulated pipes <b>2x OD 108-115 mm</b>	09612	09668	09687
	Builder <b>complete set</b> 4 heating baseplate penetration <b>double</b> DN 200	for flexible pre-insulated pipes <b>2x OD 119-128 mm</b>	09613	09669	09688
	Builder <b>complete set</b> 4 heating baseplate penetration <b>double</b> DN 200	for flexible pre-insulated pipes <b>2x OD 135-144 mm</b>	09614	09670	09689

<b>Installation kit</b> <ul style="list-style-type: none"> <li>• One Pressio®-Rings seal type FW with oversized flange</li> <li>• One set of centering ring (system raci)</li> </ul>	for subsequent addition to the basic set*	Art.-No.	
		for flexible pre-insulated pipes <b>OD 69 - 78 mm</b>	09625
		for flexible pre-insulated pipes <b>OD 88 - 103 mm</b>	09621
		for flexible pre-insulated pipes <b>OD 108 - 115 mm</b>	09622
		for flexible pre-insulated pipes <b>OD 119 - 128 mm</b>	09623
		for flexible pre-insulated pipes <b>OD 135 - 144 mm</b>	09624

\* 2 installation kits are required for a double set

## Accessories / spare parts

Product	Description	Art.-No.
Wall collar for OD 200 mm	incl. steel straps	12811
PE endcap DN 200	protective cover	13024
Rubber end seal AKT DN 200/150-0	incl. steel straps	18091
Lubricant 150 ml	for mounting the casing pipes	09599

# District Heating Baseplate Penetration 4 pipes Complete Set



## Installation dimensions

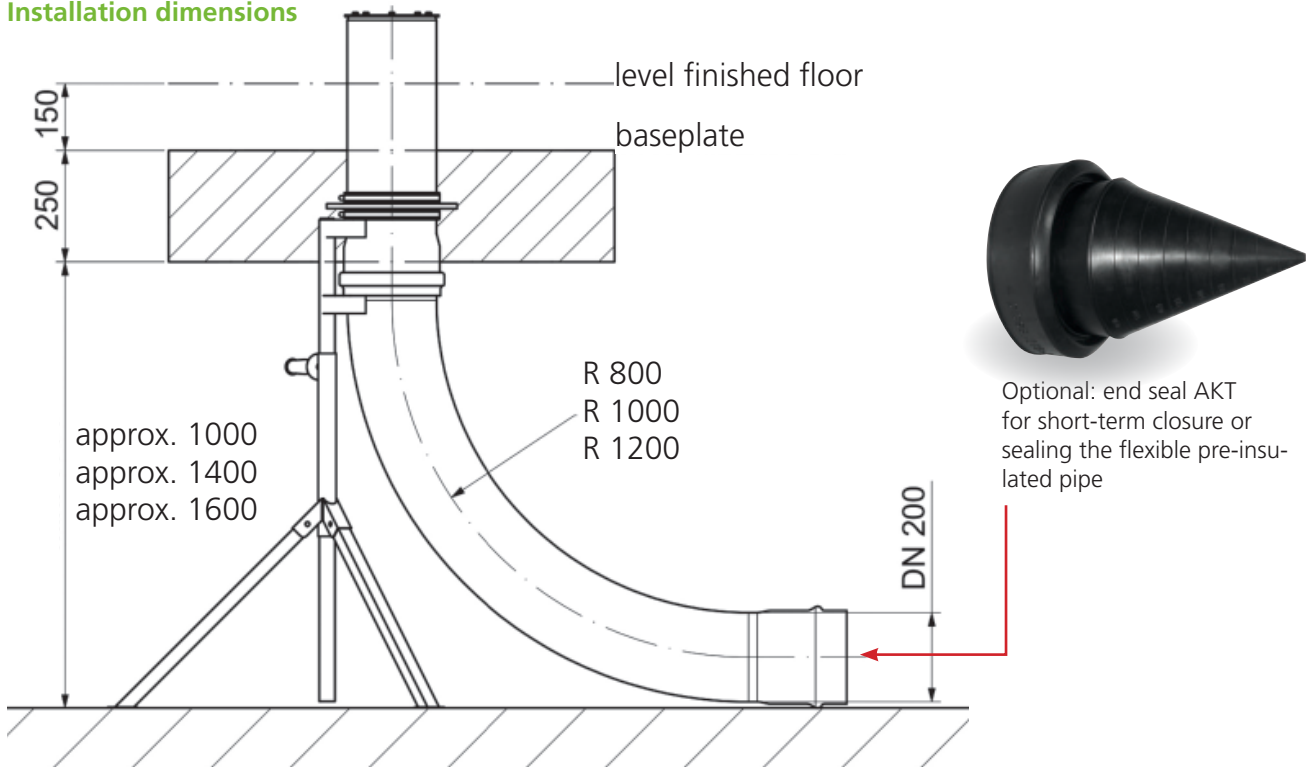

## Supplied

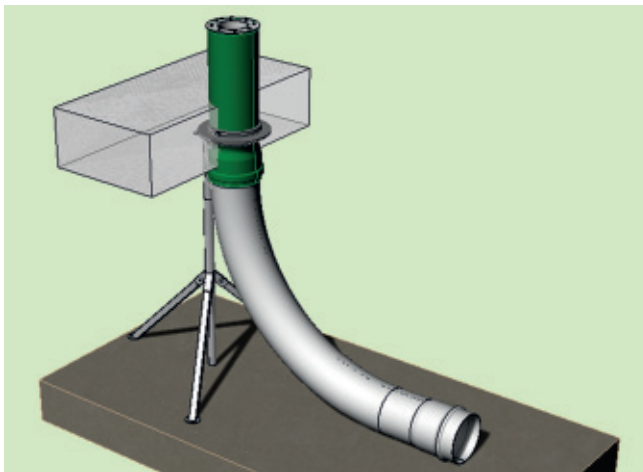

### Single Builder Complete Set 4 heating

#### Basic set

- Baseplate penetration incl. wall collar, one casing pipe for flexible preinsulated pipes up to OD 140 mm max.
- Mounting stand: telescoping tripod incl. fixing accessories
- One PVC-pipe bend
- Protective endcaps

#### Installation kit

- One kit of centering ring (system raci)
- One Pressio®-Rings seal type FW 2x40 mm with oversized flange

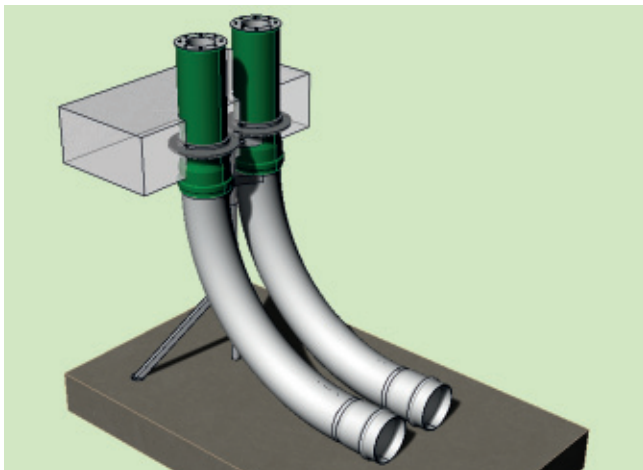

### Double Builder Complete Set 4 heating

#### Basic set

- Baseplate penetration incl. wall collar, two casing pipes for flexible preinsulated pipes up to OD 140 mm max.
- Mounting stand: extendable tripod incl. fixing accessories
- Two PVC-pipe bends
- Protective endcaps

#### Installation kit

- Two kits of centering ring (system raci)
- Two Pressio®-Rings seal type FW 2x40 mm with oversized flange





Pipeline Accessories

Fixed-Loose Flange  
4 pipes

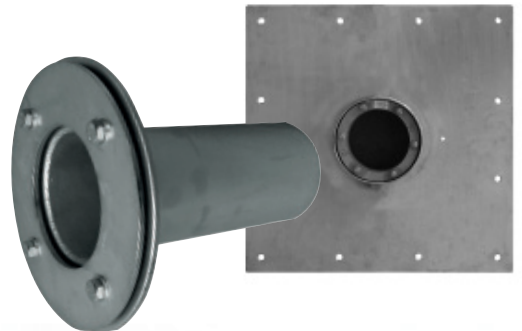

# Pressio® Wall Penetration Seals and Wall Sleeves with Fixed-Loose Flange 4 pipes

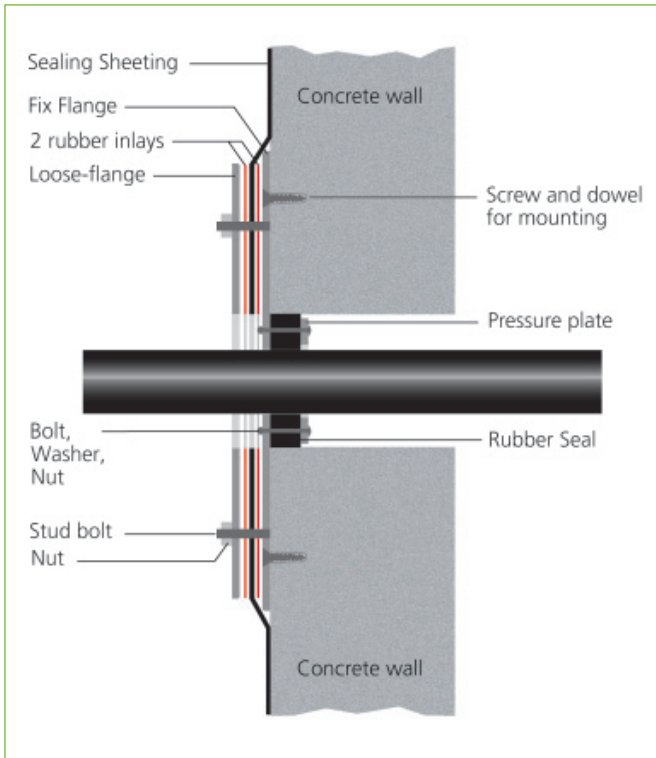

## Product information

Wall penetration seals and wall sleeves with an integrated fixed-loose flange construction securely set the penetrated sealing sheeting of a building into the wall penetration to provide reliable sealing.

Two **rubber inlays** between the flanges are designed to securely seal plastic membranes. The fixed-loose-flange constructions comply with DIN 18533 for buildings with waterproofing membranes to withstand external water pressure (W2-E) or without external water pressure (W1-E, W3-E). Alternative specifications available on request.

On-wall sleeves serve to form a sleeve in front of the wall. Here a new wall penetration seal can be applied. All on-wall sleeves are supplied with screws, dowels and special sealing adhesive to seal towards the wall.



Example for wall penetration seal with fixed-loose flange

	<p><b>Pressio® seal with fixed-loose flange to withstand low external water pressure</b> (W1-E, W3-E) according to DIN 18533 for buildings with sealing sheeting, incl. screws and dowels for mounting <b>galvanized steel version</b></p>
	<p><b>Pressio® seal with fixed-loose flange to withstand high external water pressure</b> (W2-E) according to DIN 18533 for buildings with sealing sheeting, incl. screws and dowels for mounting <b>galvanized steel version</b></p>
	<p><b>wall sleeve with fixed-loose flange (W1-E, W3-E)</b> according to DIN 18533 for buildings with sealing sheeting <b>to withstand low external water pressure</b> <b>galvanized steel version</b></p>
	<p><b>wall sleeve with fixed-loose flange (W2-E)</b> according to DIN 18533 for buildings with sealing sheeting <b>to withstand high external water pressure</b> <b>galvanized steel version</b></p>
	<p><b>on-wall sleeve with fixed-loose flange</b> (W1-E, W3-E) according to DIN 18533 for buildings with sealing sheeting, incl. screws and dowels for mounting <b>to withstand low external water pressure</b> <b>galvanized steel version</b></p>
	<p><b>on-wall sleeve with fixed-loose flange (W2-E)</b> according to DIN 18533 for buildings with sealing sheeting, incl. screws and dowels for mounting <b>to withstand high external water pressure</b> <b>galvanized steel version</b></p>
	<p><b>on-wall sleeve, closed</b> incl. screws, dowels and sealing adhesive <b>galvanized steel version (Pressio® seal NOT included)</b></p>
	<p><b>on-wall sleeve, split</b> incl. screws, dowels and sealing adhesive <b>galvanized steel version (Pressio® seal NOT included)</b></p>

# Pressio® Wall Penetration Seals and Wall Sleeves with Fixed-Loose Flange 4 pipes

## Penetration seal with Fixed-Loose Flange

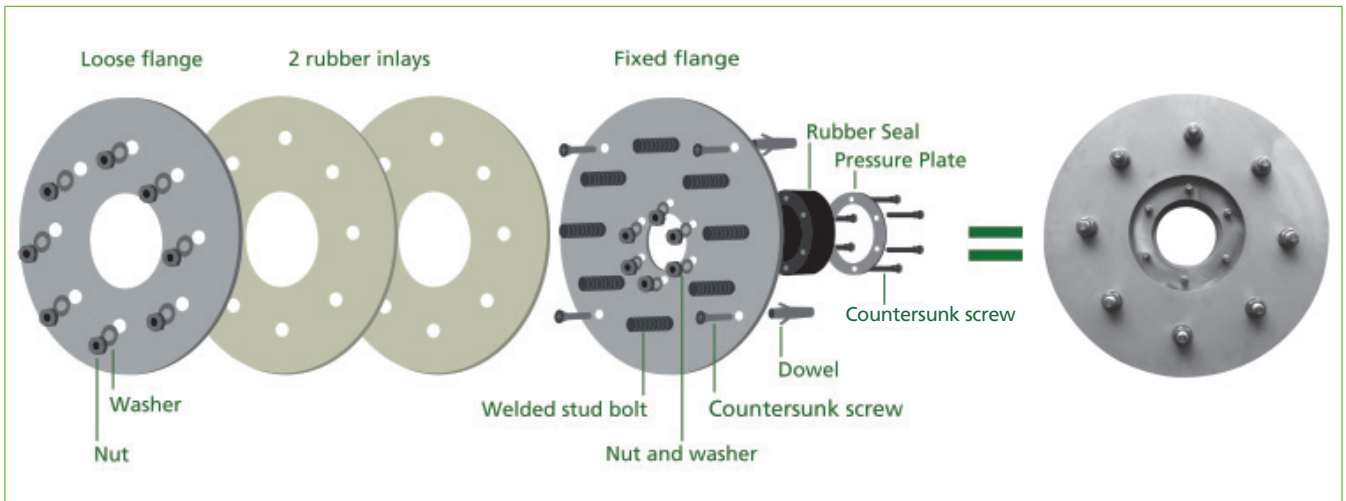

## Wall Sleeve with Fixed-Loose Flange

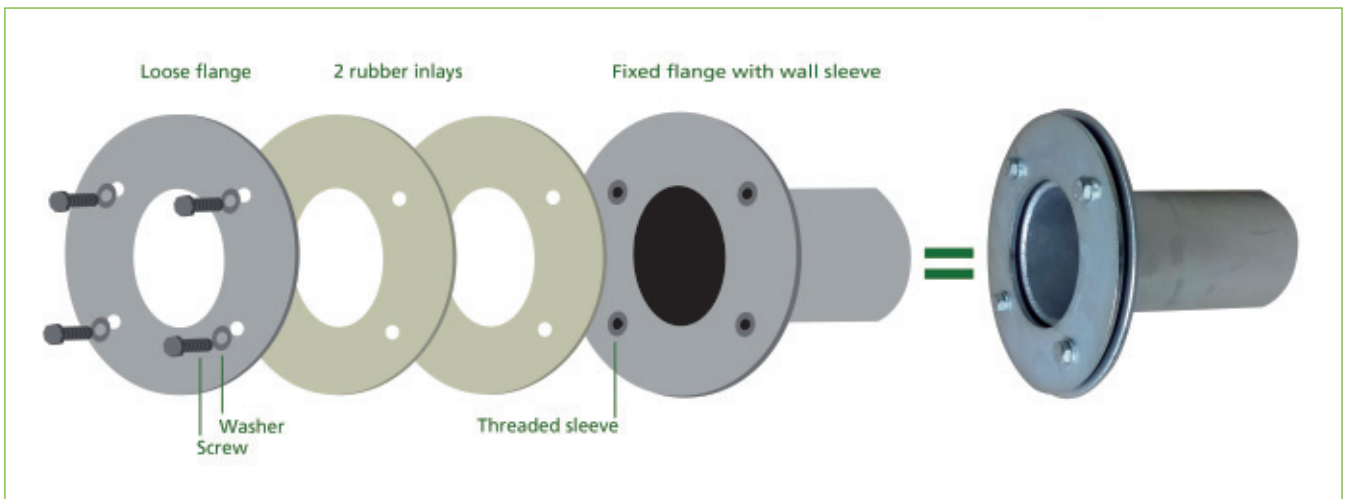

## Example of on-wall sleeve



## Example with fixed-loose flange

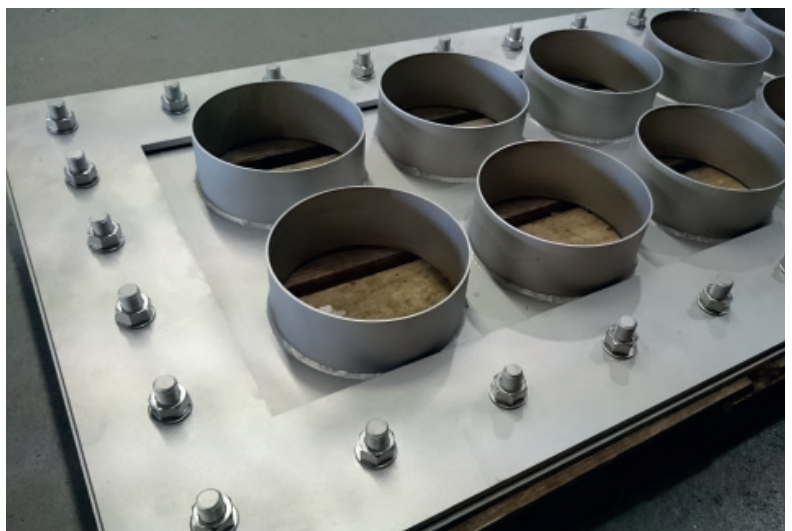



# Application Instructions

## Pressio® Seal with Fixed-Loose Flange 4 pipes

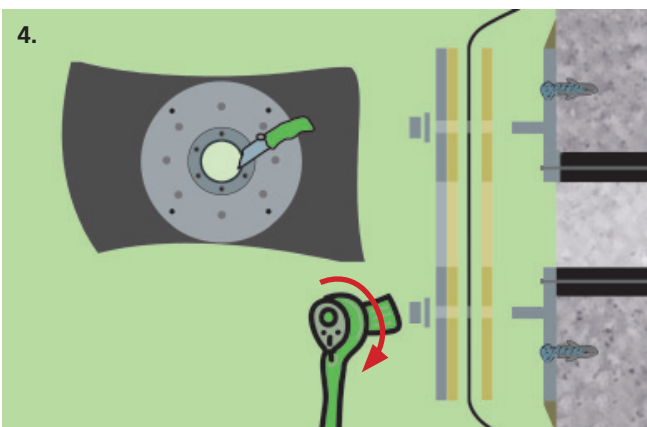
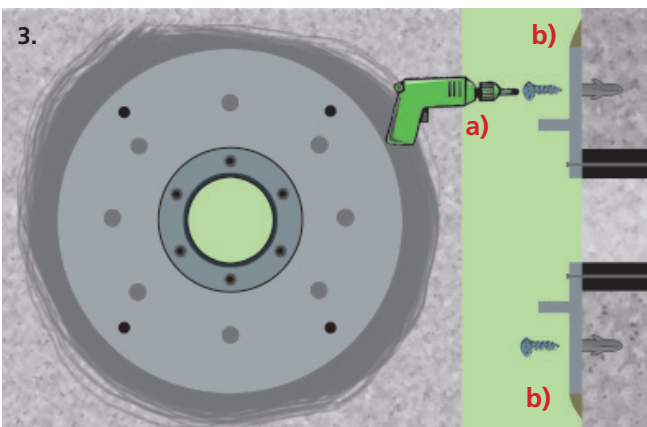
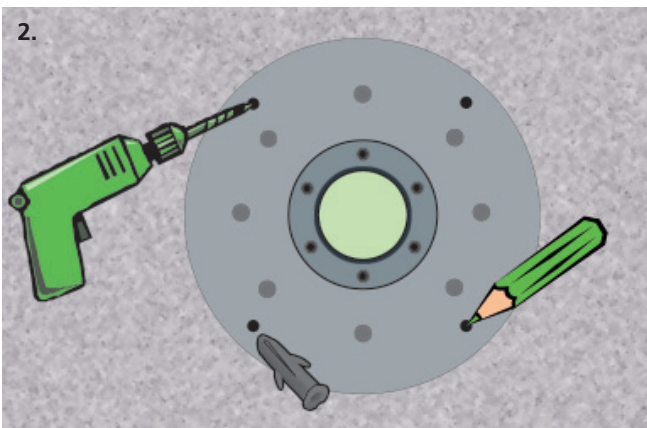
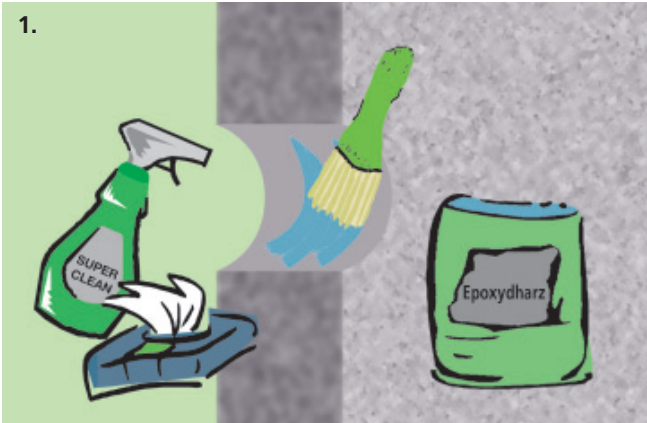

### Requirements:

- The penetration seal with fixed-loose flange 4 pipes must be installed on a flat, smooth and load-bearing wall surface.
- The core hole and the wall surfaces must be clean. We recommend the Epoxy coating resin 4 pipes, which guarantees a high-quality coating on the concrete surface to repair any unevenness.
- Ensure that the fixed-loose flange construction is installed with a minimum distance of 30 cm to any outer wall edge and minimum 50 cm to structural wall joints (acc. to DIN 18533-1).

### 1. Preparation

- Choose the position of the fixed-loose flange according to DIN 18533-1.
- Clean the Pressio® seal with fixed-loose flange 4 pipes, the wall and the core hole. (free of oil and dust)
- Level out any unevenness and allow to harden. (Recommendation: Epoxy coating resin 4 pipes)

### 2. Mark

- Disassemble the loose flange.
- Insert the fixed flange with the rubber seal into the core hole.
- Turn the holes of the countersunk screws to the desired position and slightly tighten the rubber seal. (centering)
- Mark the dowel holes.
- Loosen and remove the fixed flange with rubber seal.
- Drill dowel holes.
- Blow dust out of the holes and insert dowels into the wall.

Dowel size	minimum edge distance in concrete
10 mm	50 mm
12 mm	60 mm

Origin: fischerwerke GmbH

### 3. Screwing

- Clean the fixed flange and the rubber seal. Assemble them with the countersunk screws. (tighten firmly)
- Use mortar to level the edge from the fixed flange to the wall.

**Attention: A proper cleaning of the sealing surfaces is required!**

### 4. Assembly and Cutting

- Mount sealing sheeting, use the loose flange as a template and cut out the holes for the feed-through/ screws using a punching tool.
- Mount the sealing sheeting on the hole pattern with the rubber inlays on both sides.
- Assemble the loose flange and tighten the nuts according to DIN 18533-1 torque specification.

# Application Instructions

## Wall Sleeve with Fixed-Loose Flange 4 pipes

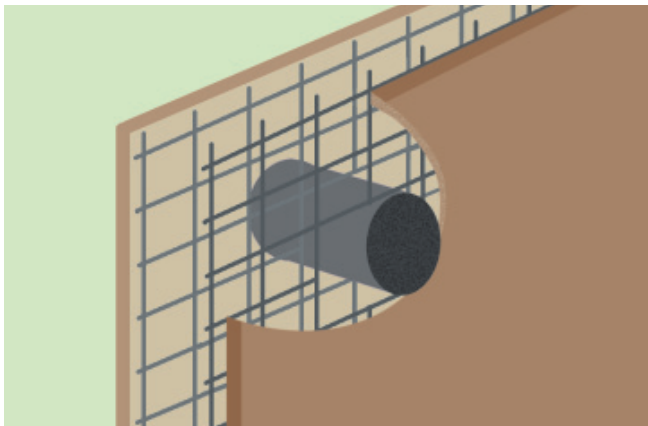

### 1. Preparation

- Clean the fixed-loose flange. (free of oil and dust)
- Choose the position of the fixed flange according to DIN 18533-1.
- Integrate and place the fixed flange with the wall sleeve into the formwork.  
(Use a pipe clamp or reinforcement for fixation of the wall sleeve. Not included in the delivery.)
- Ensure that the fixed-loose flange construction is installed with a minimum distance of 30 cm to any outer wall edge and minimum 50 cm to structural wall joints (acc. to DIN 18533-1).

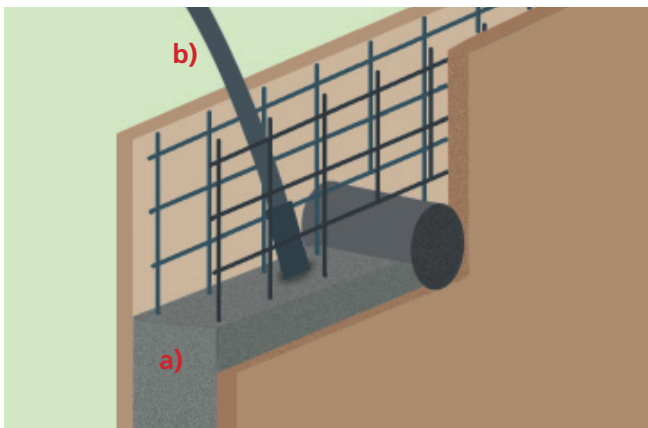

### 2. Concreting

- Pour concrete into the formwork.
- Pay attention to the compaction around the wall sleeve.

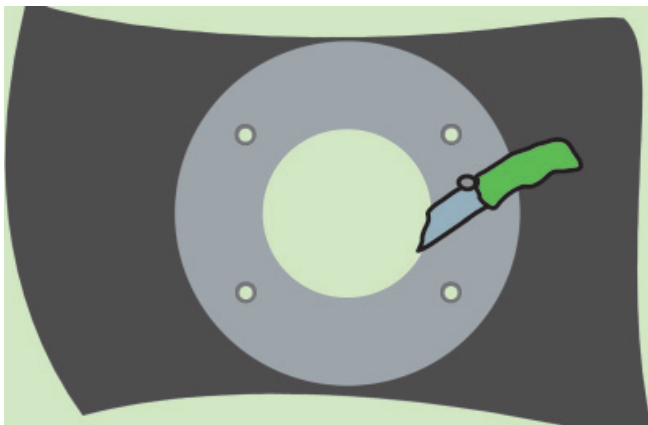

### 3. Cutting

Cut the drill holes and the feed-through hole into the sealing sheeting. (Use the loose flange as a template)

#### Attention:

Ensure that the sealing sheeting under the flange is free of joints, wrinkles, etc.!

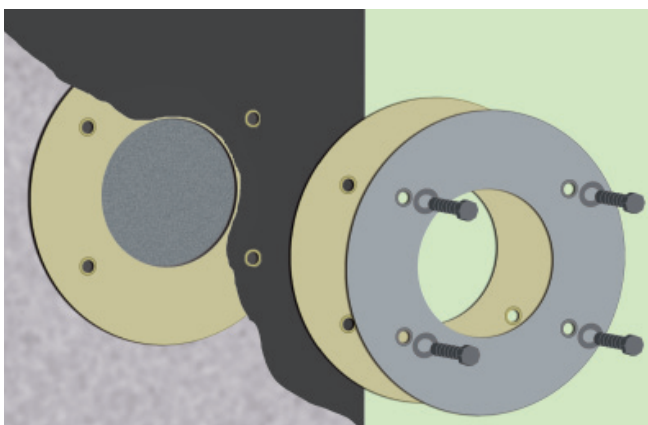

### 4. Assembling

- First apply the rubber inlay on the fixed flange.
- Mount the sealing sheeting.  
(Attention: All drill holes must be aligned to each other!)
- Assemble loose flange with rubber inlay, washers and the screws.
- Assemble the loose flange and tighten the screws according to DIN 18533-1 torque specification.

# Application Instructions

## On-wall Sleeve with Fixed-Loose Flange 4 pipes

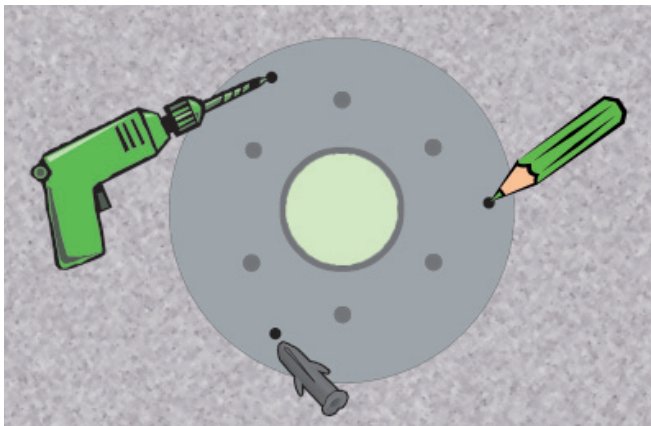

1. a) Choose the position of the on-wall sleeve according to DIN 18533-1.
- b) Wall surface has to be clean and even.
- c) Mark the dowel holes.
- d) Drill dowel holes.
- e) Blow dust out of the holes and insert dowels into the wall.

Dowel size	minimum edge distance in concrete
10 mm	50 mm
12 mm	60 mm

Origin: fischerwerke GmbH

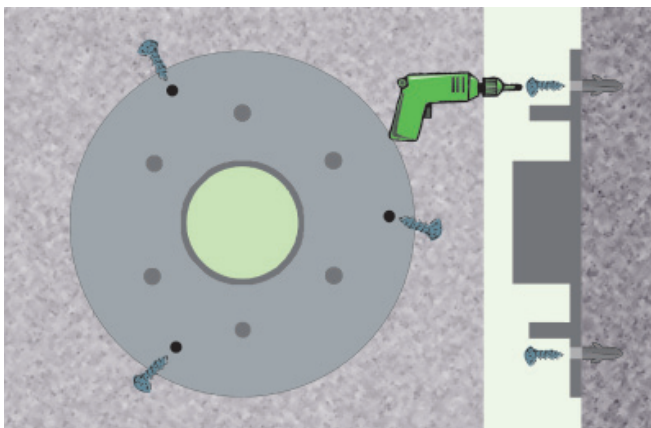

2. Screw the fix on-wall sleeve with the supplied hexagon head screws to the wall.

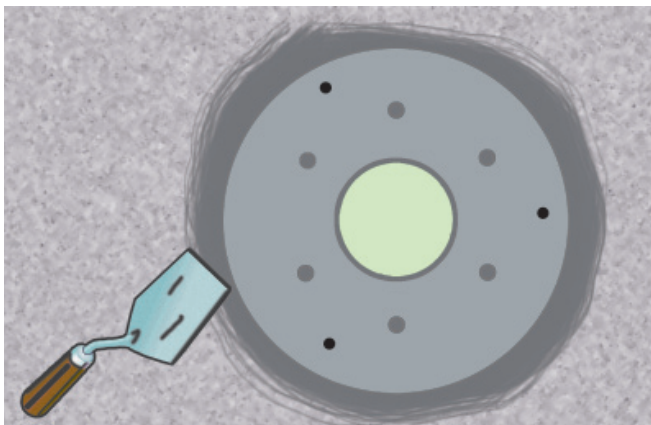

3. Use mortar to level the edge from the fixed flange to the wall.

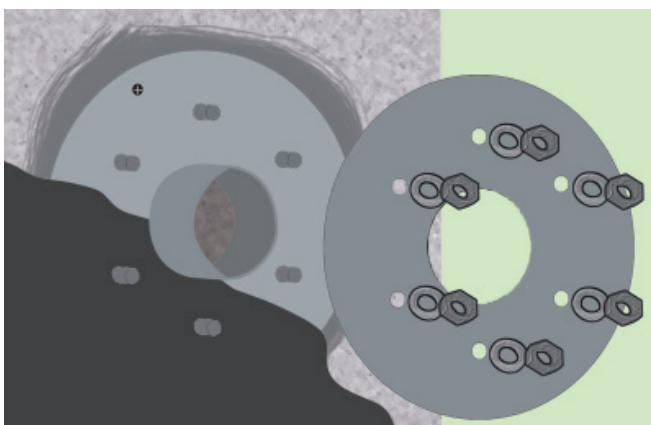

4. a) Put on the sealing sheeting, use the loose flange as a template and cut out the screw holes with a punching tool.
- b) Mount the sealing sheeting on the hole pattern with the rubber inlays on both sides.
- c) Assemble the loose flange and tighten the nuts according to DIN 18533-1 torque specification.



# Application Instructions

## On-wall Sleeve 4 pipes

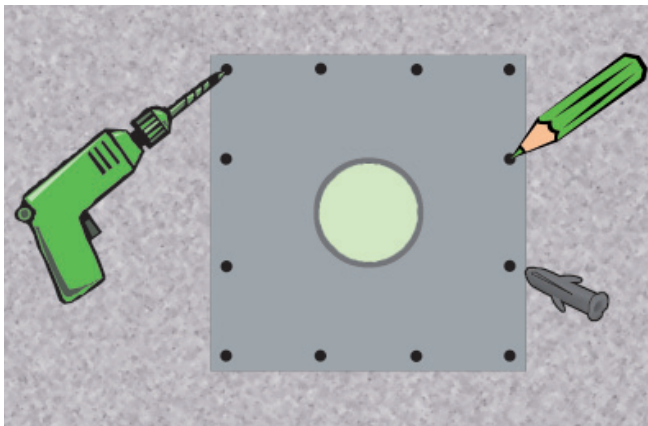

The front of the on-wall sleeve 4 pipes must be installed on a flat, smooth and load-bearing wall surface.

### 1. Preparation

- Choose the position of the on-wall sleeve according to DIN 18533-1.
- Mark the dowel holes.
- Drill dowel holes.
- Blow dust out of the holes and insert dowels into the wall.

Dowel size	minimum edge distance in concrete
14 mm	70 mm

Origin: fischerwerke GmbH

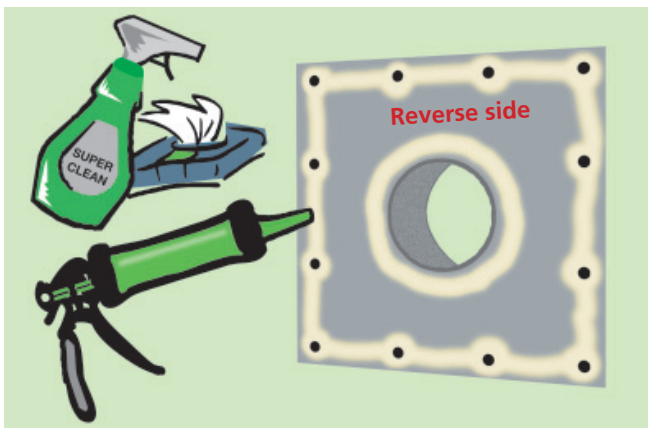

### 2. Gluing

- Clean the adhesive on surface on the wall and the on-wall sleeve.
- Apply the sealing adhesive evenly on the rear side of the wall sleeve plate. All openings on the wall side have to be sealed that way. (see image)

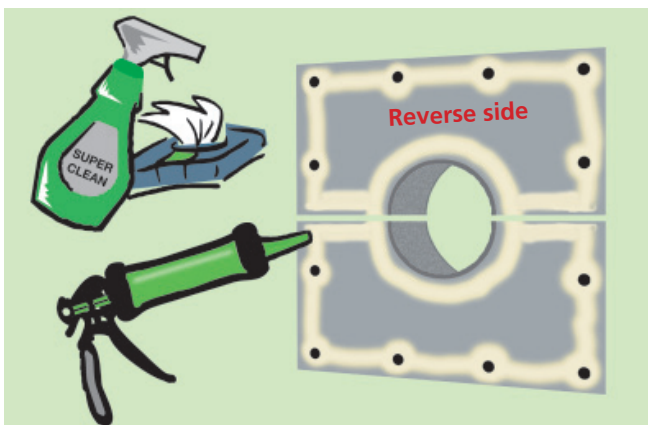

- (Optional) In case of a split on-wall sleeve version: apply the adhesive on the surface and along the edges of the wall plates. (see image)

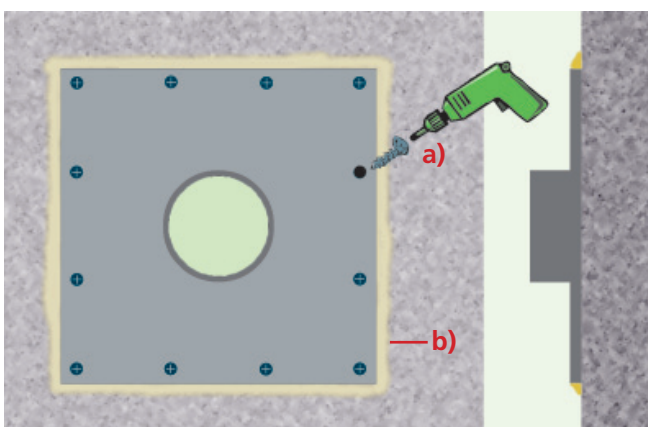

### 3. Assembling

- Assemble on-wall sleeve and tighten screws.
- Check adhesive sealant squeezes out evenly on all sides.

**Attention:** Please make an additional request for the wall penetration seal



Pipeline Accessories

Pressio®-Elements  
Modular Wall Penetration  
Seals 4 pipes



# Pressio®-Elements 4 pipes Modular Wall Penetration Seals

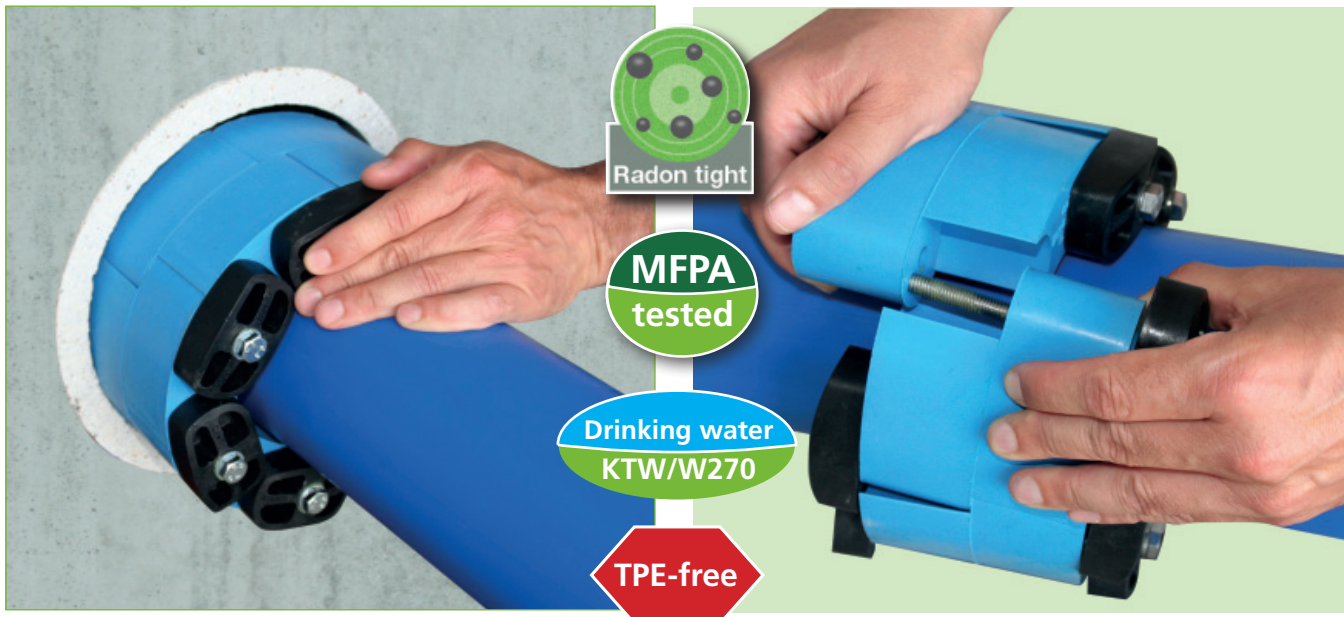

Pressio®-Elements modular wall penetration seals are an excellent choice to seal annular spaces between wall and pipe/cable securely so they are watertight and gas-tight.

Pressio®-Elements modular seals can be used flexibly because of their variable sizes for different combinations of wall sleeves/core holes and carrier pipes. These seals prevent leaks in case of gas and high external water pressure.

### Application

By compressing the rubber between the polyamide pressure plates, a gas-tight and watertight closure of the annular space between the carrier pipe and the casing pipe can be achieved. Pressio®-Elements modular seals can always be **used for retrofit application**.

Pressio®-Elements modular wall penetration seals are not suitable for especially thin-walled plastic pipes (e.g. flexible preinsulated pipe). Here we recommend Pressio® Seals for district heating pipes.

### Pressure rating and MFWA test

- Type C, S 316, OC, OS316, KTW/W270 and TS **up to 5.0 bar pressure tight**
- Type BC and BS 316: **up to 3.0 bar pressure tight**
- **Drinking water quality according to DVGW W270, Elastomer guideline of UBA / KTW - BWGL Declaration of Conformity**
- Radon tight, gas tight
- Fire class E acc. to EN13501-1 (formerly B2) normal flammability



To calculate the right Pressio®-Elements our calculation programme via our website <http://www.4pipes.de> is at your disposal.

### More Advantages

- Made of high quality materials
- Fast mounting
- Retrofit application possible
- Applicable for various constructions
- Cost-efficient solution
- Fast delivery, standard versions in stock
- Different colours make the various rubber qualities easily distinguishable
- electrical isolation between pipe and sleeve
- noise protection
- anti vibration application
- Easy storage
- Radon tight, gas tight

The 4 pipes warranty only applies to faulty material. Checking the suitability of the product for the individual application is solely the responsibility of the user.











# Pressio®-Elements 4 pipes Modular Wall Penetration Seals

## Product information

Pressio®-Elements 4 pipes are available in various material quality-combinations.

<p><b>Quality C and S316</b></p> 	<ul style="list-style-type: none"> <li>• <b>Type C:</b> EPDM rubber black (50 ± 5 Shore A, standard rubber for cable, steel- and cast iron pipes), bolts galv., pressure plates polyamide 6-30, <b>operation temperature: -40°C bis +80°C</b></li> <li>• <b>Type S316:</b> EPDM rubber black (50 ± 5 Shore A, standard rubber for cable, steel- and cast iron pipes), stainless steel bolts (V4A), pressure plates polyamide 6-30, <b>operation temperature: -40°C up to +80°C</b> Normal flammability MFPA tested Class E acc. to DIN EN 13501-1</li> </ul>
<p><b>Quality BC and BS316</b></p> 	<ul style="list-style-type: none"> <li>• <b>Type BC:</b> EPDM rubber blue (40 ± 5 Shore A, soft rubber especially suitable for plastic pipes), bolts galv., pressure plates polyamide 6-30, <b>operation temperature: -40°C bis +80°C</b></li> <li>• <b>Type BS316:</b> EPDM rubber blue (40 ± 5 Shore A, soft rubber especially suitable for plastic pipes), stainless steel bolts (V4A), pressure plates polyamide 6-30, <b>operation temperature: -40°C up to +80°C</b> Normal flammability MFPA tested Class E acc. to DIN EN 13501-1</li> </ul>
<p><b>Quality OC and OS316</b></p> 	<ul style="list-style-type: none"> <li>• <b>Type OC:</b> Nitrile rubber green (50 ± 5 Shore A, nitrile rubber oil- and fuel resistant), bolts galv., pressure plates polyamide 6-30, Attention: rubber is not UV-resistant, <b>operation temperature: -40°C up to +70°C</b></li> <li>• <b>Type OS316:</b> Nitrile rubber green (50 ± 5 Shore A, nitrile rubber oil- and fuel-resistant), stainless steel bolts (V4A), pressure plates polyamide 6-30, Attention: rubber is not UV-resistant, <b>operation temperature: -40°C up to +70°C</b></li> </ul>
<p><b>Quality KTW/W270</b></p> 	<ul style="list-style-type: none"> <li>• <b>Type KTW/W270:</b> EPDM rubber <b>black</b>, (50 ± 5 Shore A, pressure plates and rubber approved acc. to <b>KTW/W270 / VBA-BWGL</b>) bolts and nuts made of V4A stainless steel, pressure plate fibreglass reinforced Polyamide <b>white</b>, <b>operation temperature: -40°C up to +80°C</b></li> </ul> 
<p><b>Quality TS</b></p> 	<ul style="list-style-type: none"> <li>• <b>Type TS:</b> Silicone rubber grey (45 ± 5 Shore A, high temperature resistance) pressure plates V2A stainless steel, bolts V4A stainless steel <b>operation temperature: -55°C up to +204°C</b></li> </ul>

## Examples for applications:

...in core drilled hole

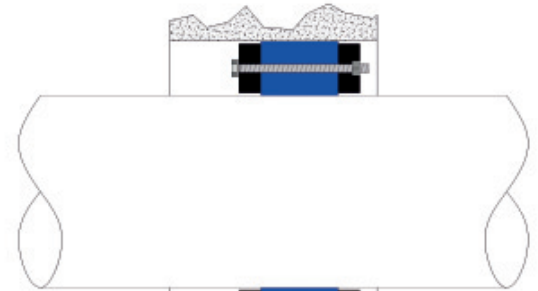

...in wall sleeve made of fibre cement

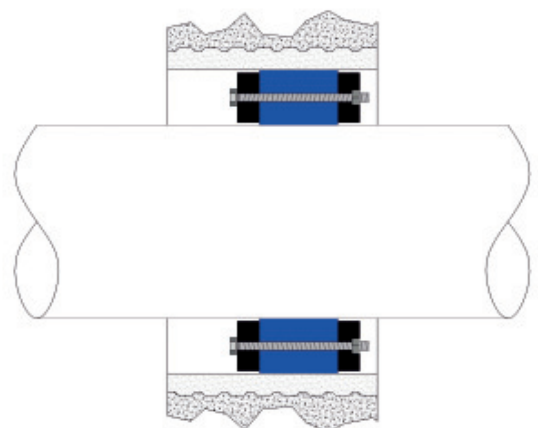

...in steel wall sleeve with puddle flange (anchor flange)

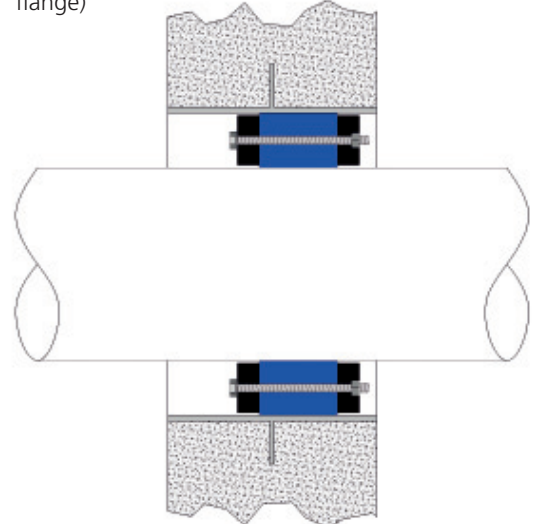

# Pressio®-Elements 4 pipes Modular Wall Penetration Seals

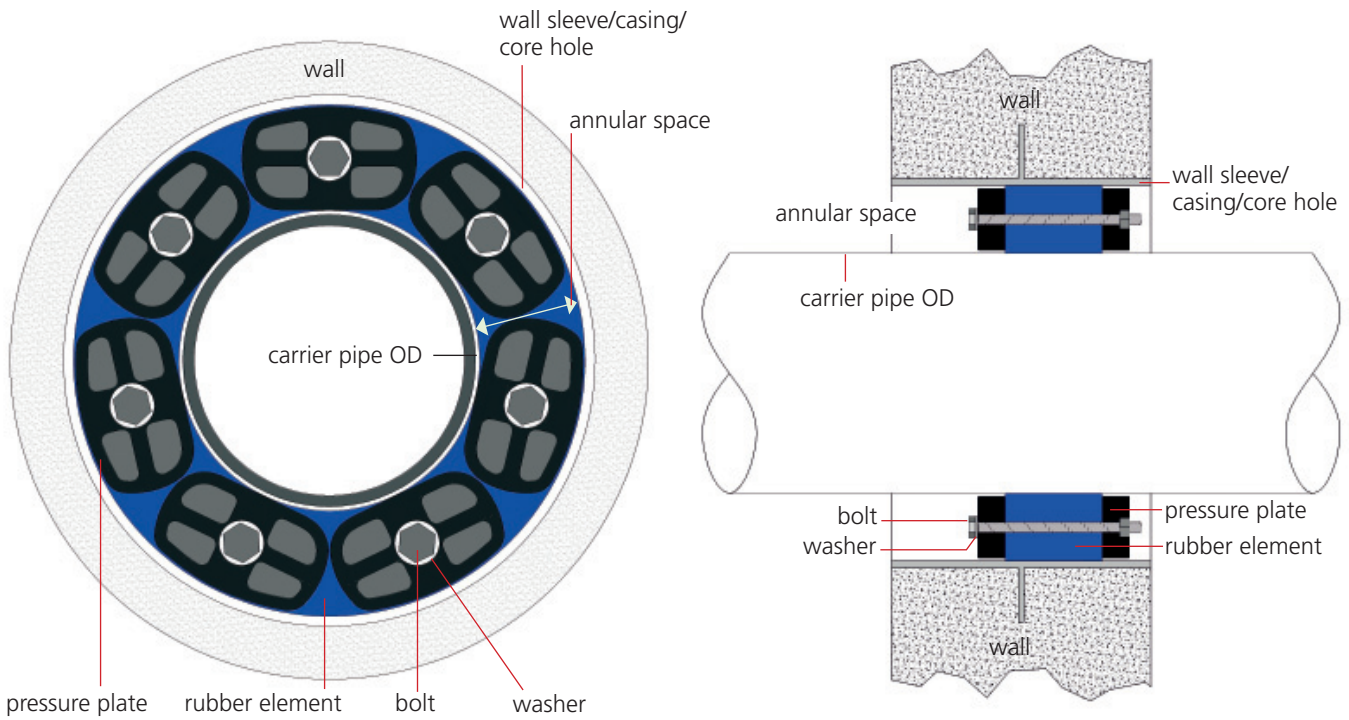

## IL 100 up to IL 315

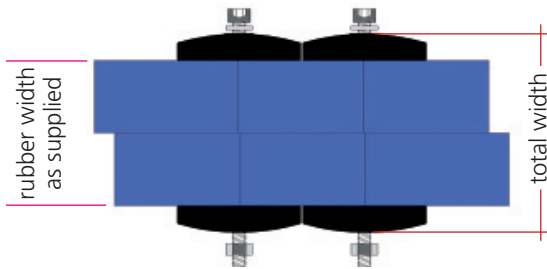

## IL 325 up to IL 700

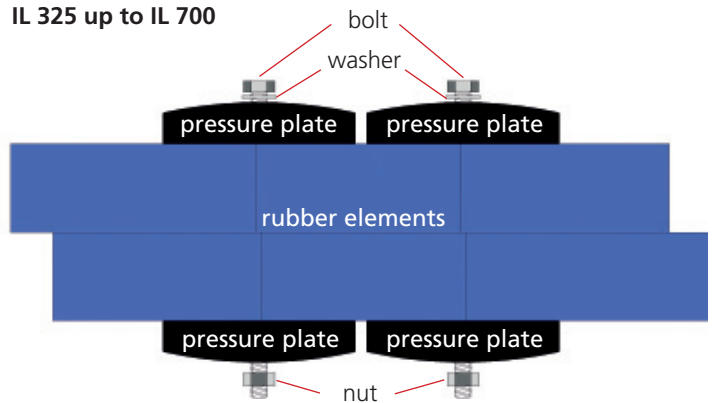

IL 100 - IL 315 4 pipes - bolts with inner hex head  
- solid pressure plates

IL 325 - IL 700 4 pipes - bolts with outer hex head  
- profiled pressure plates



# Pressio®-Elements 4 pipes Modular Wall Penetration Seals



## Pressio®-Elements 4 pipes – Dimensions in mm

Pressio® Elem. Type	sealing range		arc length	carrier pipe		width of rubber part when delivered	total width when delivered	Minimum amount elements/ ring	min. wall thick- ness	bolt	Head of bolts	tool size
	min.	max.		min. Ø	max. Ø							
IL 100	9.0	12.5	31.0	25.0	219.0	45	60	4	60	M 4 x 60	Inner hexhead	3 mm
IL 200	12.5	15.7	30.0	21.3	323.9	45	63	4	63	M 5 x 70	Inner hexhead	4 mm
IL 265	16.0	20.0	41.0	50.0	406.4	45	63	5	63	M 5 x 70	Inner hexhead	4 mm
IL 275	16.0	20.0	25.6	0.0	90.0	45	63	4	63	M 5 x 70	Inner hexhead	4 mm
IL 300	18.0	22.5	41.0	44.5	273.0	65	90	5	90	M 6 x 90	Inner hexhead	5 mm
IL 310	18.0	22.5	57.0	60.3	406.4	65	90	5	90	M 6 x 90	Inner hexhead	5 mm
IL 315	21.1	26.0	38.4	37.0	323.9	65	90	5	90	M 6 x 90	Inner hexhead	5 mm
IL 325	23.2	30.0	79.0	133.0	711.0	65	100	6	100	M 6 x 100	Outer hexhead	10 mm
IL 340	25.5	34.0	41.4	30.0	323.9	65	100	4	100	M 6 x 100	Outer hexhead	10 mm
IL 360	32.0	42.0	55.1	40.0	406.4	65	100	5	100	M 6 x 100	Outer hexhead	10 mm
IL 400	36.0	46.0	93.1	139.7	1220.0	85	125	6	125	M 8 x 130	Outer hexhead	13 mm
IL 410	37.0	48.5	67.6	60.3	323.9	85	125	5	125	M 8 x 130	Outer hexhead	13 mm
IL 425	28.0	37.0	93.1	144.0	1220.0	85	125	6	125	M 8 x 130	Outer hexhead	13 mm
IL 440	44.0	55.0	99.0	139.7	1220.0	85	125	6	125	M 8 x 130	Outer hexhead	13 mm
IL 475	41.0	48.5	68.6	60.3	1220.0	85	125	5	125	M 8 x 130	Outer hexhead	13 mm
IL 500	60.0	71.5	99.8	100.0	1220.0	90	140	5	140	M 10 x 150	Outer hexhead	17 mm
IL 525	55.0	63.5	99.8	133.0	1220.0	90	140	6	140	M 10 x 150	Outer hexhead	17 mm
IL 575	48.0	58.0	79.3	88.9	1220.0	90	140	5	140	M 10 x 150	Outer hexhead	17 mm
IL 615	81.0	98.0	155.5	219.0	3000.0	100	165	6	165	M 12 x 180	Outer hexhead	19 mm
IL 625	81.0	98.0	106.7	88.9	2000.0	100	165	5	165	M 12 x 180	Outer hexhead	19 mm
IL 650	69.0	84.0	106.7	88.9	2000.0	100	165	5	165	M 12 x 180	Outer hexhead	19 mm
IL 700	95.0	110.0	155.5	219.0	3000.0	100	165	6	165	M 12 x 180	Outer hexhead	19 mm

All data in mm

### Selecting the seal:

#### 1. Annular Space Calculation

$$\frac{\text{casing pipe ID} - \text{carrier pipe OD}}{2} = \text{annular space}$$

Choose Pressio® Elements Type for annular space from table to calculate the right quantity.

#### 2. Quantity of Elements

$$\frac{\text{casing pipe ID} + \text{carrier pipe OD}}{2} \times 3,14 = \text{bolt circle : arc length} = \text{amount of elements}^*$$

\*Mathematical rounding:

when... .49 round down to the nearest whole number of elements

when... .50 round up to the nearest whole number of elements

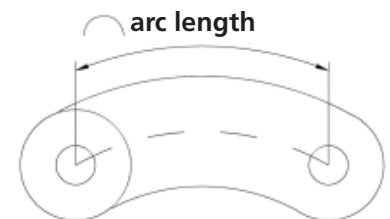

To calculate the right number of Pressio®-Elements there is also our calculation programme via our website [www.4pipes.de](http://www.4pipes.de) at your disposal.



# Pressio®-Elements-Set 4 pipes



Pressio®-Elements-Set preassembled to a ready-to-use ring, supplied in a box, perfect for keeping in stock.

### Set features:

- Standard EPDM blue/soft
- Bolts stainless or carbon steel
- Separable for retrofit application
- Easy to select type required
- One carton per sealing ring
- Other sets on request
- We use brown carton for the sake of the environment

Corehole/ sleeve ID in mm	Pipe OD Ø <sub>a</sub> (mm)		Quality BC galvanized bolts	Quality BS 316 stainless steel bolts
	min.	max.	Art.-No.	Art.-No.
50	1	18	09000	09100
	18	25	09001	09101
80	22	27	09010	09110
	40	48	09011	09111
100	32	45	09020	09120
	48	57	09021	09121
	55	64	09022	09122
125	42	61	09030	09130
	57	74	09031	09131
	80	89	09032	09132
150	53	76	09040	09140
	66	78	09041	09141
	82	99	09042	09142
	105	115	09043	09143
200	84	104	09050	09150
	103	117	09051	09151
	116	133	09052	09152
	132	149	09053	09153
	148	157	09054	09154
250	156	164	09055	09155
	107	129	09060	09160
	134	154	09061	09161
	153	163	09062	09162
	158	177	09063	09163
300	176	193	09064	09164
	184	204	09070	09170
	203	217	09071	09171
	216	236	09072	09172
350	207	229	09080	09180
	234	254	09081	09181
	253	274	09082	09182
	266	286	09083	09183

# Pressio®-Elements 4 pipes Selection Guide for Core Drilled Holes

 Core hole mm ID	Carrier pipe OD in mm		Number of elements	Type IL...
	min.	max.		
50	10	18	4	275
	25	32	4	100
70	30	36	6	275
	39	45	6	200
	45	52	6	100
80	40	48	8	275
	49	55	7	200
	55	62	7	100
100	32	45	5	340
	48	57	6	315
	55	64	6	300
	62	68	6	265
	68	75	9	200
125	75	82	9	100
	42	61	5	360
	58	74	7	340
	73	82	8	315
	80	89	8	300
	87	93	8	265
	95	100	12	200
150	100	107	12	100
	58	76	5	410
	66	82	6	360
	82	99	9	340
	105	114	7	310
	112	118	10	265
	118	125	14	200
	125	132	14	100
200	90	104	6	575
	103	117	7	475
	103	124	7	410
	116	133	9	360
	132	149	13	340
	155	164	10	310
250	134	154	8	575
	140	160	6	440
	153	163	9	475
	158	177	7	400
	166	186	12	360
	178	192	7	425
	190	203	9	325
	206	212	12	310
300	157	173	7	500
	184	204	10	575
	190	210	8	440
	208	226	12	410
	216	236	15	360
	234	244	20	340
	240	253	11	325
	255	264	15	310

 Core hole mm ID	Carrier pipe OD in mm		Number of elements	Type IL...	
	min.	max.			
350	182	210	8	650	
	207	229	9	500	
	223	239	9	525	
	234	254	12	575	
	253	267	14	475	
	253	274	14	410	
	266	286	18	360	
	258	274	10	400	
	276	293	11	425	
	286	296	24	340	
	294	303	13	325	
	307	314	18	310	
	400	204	234	9	625
		234	255	9	650
		264	279	10	500
273		289	11	525	
284		304	14	575	
292		310	11	440	
303		317	16	475	
308		327	12	400	
326		341	12	425	
340		353	15	325	
450	235	256	7	700	
	254	265	10	625	
	266	286	7	615	
	285	311	11	650	
	307	329	12	500	
	327	339	12	525	
	335	354	16	575	
	345	356	13	440	
	355	367	19	475	
	358	377	14	400	
	376	393	14	425	
	375	386	24	360	
	390	403	17	325	
500	285	306	8	700	
	304	334	12	625	
	335	359	12	650	
	357	379	14	500	
	373	389	14	525	
	385	400	18	575	
	390	410	14	440	
	408	427	15	400	
	426	443	16	425	
	440	453	19	325	
600	385	406	10	700	
	404	434	15	625	
	436	457	15	650	
	457	479	17	500	
	473	489	17	525	
	490	503	17	440	
	503	509	25	475	
	508	527	19	400	
	526	543	19	425	
	540	553	23	325	

For more combinations see our calculation program

# Pressio®-Elements 4 pipes Selection Guide for Pipe OD



## Selection guide for plastic pipes (PE-HD, PVC, PP) PE-HD eg.: DIN 8074 PVC eg.: DIN 8062; 8079; 19531

carrier pipe OD Ø	core drilled hole recomm. ID Ø mm	tolerance	wall sleeve fibre cement ID Ø mm	wall sleeve PVC ID Ø mm	wall sleeve steel ID Ø mm				core hole mm		Pressio®- Elements number of elements	Type	
					Ø a	x	s	Ø i	min.	max.			
10	16	50	-2/+6	-	50	60.3	x	2.3	55.7	48.0	56	4	IL 275
15	20	50	-0/+1	-	50	-	x	-	-	50.3	51.4	4	IL 200
20	25	50	-2/+0	-	50	-	x	-	-	48.1	50	4	IL 100
25	25	80	-3/+13	80	80	88.9	x	2.9	83.1	77.7	93	4	IL 340
25	32	50	-0/+6	-	50	-	x	-	-	50.0	56	4	IL 100
25	32	60	-1/+3	-	60	63.5	x	2.3	58.9	59.0	63.4	5	IL 200
25	32	70	-6/+2	-	70	76.1	x	2.6	70.9	64.3	72	6	IL 275
32	40	60	-2/+5	-	60	63.5	x	2.3	58.9	58.0	65	5	IL 100
32	40	70	-1/+2	-	70	76.1	x	2.6	70.9	69.4	72	6	IL 200
32	40	100	-9/+4	100	100	101.6	x	2.9	95.8	91.0	104	5	IL 340
40	50	70	-2/+5	-	70	76.1	x	2.6	70.9	68.0	75	6	IL 100
40	50	80	-2/+1	80	80	-	x	-	-	78.9	81.4	7	IL 200
40	50	100	-6/+2	100	100	-	x	-	-	93.8	102	6	IL 315
40	50	125	-6/+9	125	125	133.0	x	3.6	125.8	119.2	134	5	IL 360
50	63	100	-1/+6	100	100	108.0	x	2.9	102.2	99.0	106	6	IL 300
50	63	125	-7/+6	125	125	133.0	x	3.6	125.8	117.2	131	7	IL 340
50	63	150	-7/+10	150	150	159.0	x	4.0	151.0	143.9	160	5	IL 410
65	75	100	-3/+0	100	100	-	x	-	-	97.4	100	9	IL 100
65	75	125	-7/+2	125	125	-	x	-	-	118.3	127	8	IL 315
65	75	150	-11/+5	150	150	159.0	x	4.0	151.0	139.0	155	6	IL 360
80	90	125	-3/+3	125	125	133.0	x	3.6	125.8	122.0	130	8	IL 265
80	90	130	-0/+5	-	-	139.7	x	3.6	132.5	130.0	135	9	IL 300
80	90	150	-6/+8	150	150	159.0	x	4.0	151.0	143.6	158	9	IL 340
100	110	150	-4/+5	150	150	159.0	x	4.0	151.0	146.0	155	7	IL 310
100	110	200	-7/+7	200	200	-	x	-	-	192.6	207	7	IL 475
100	110	225	-2/+1	-	-	-	x	-	-	222.7	226	7	IL 575
125	125	180	-3/+11	-	-	193.7	x	5.6	182.5	176.0	193	11	IL 340
125	125	200	-10/+6	200	200	-	x	-	-	190.0	206	9	IL 360
125	125	225	-2/+15	-	-	244.5	x	6.3	231.9	222.7	241	7	IL 575
125	125	250	-4/+18	250	250	267.0	x	6.3	254.4	247.8	268	6	IL 500
125	140	200	-4/+8	200	200	-	x	-	-	196.3	208	13	IL 340
125	140	210	-4/+14	-	-	219.1	x	4.5	210.1	206.9	224	10	IL 360
125	140	225	-3/+10	-	-	244.5	x	6.3	231.9	222.0	235	8	IL 475
125	140	250	-2/+6	250	250	267.0	x	6.3	254.4	247.9	256	8	IL 575
125	140	260	-5/+9	-	-	273.0	x	5.0	263.0	260.0	269	6	IL 500
125	140	300	-22/+5	300	300	-	x	-	-	278.0	305	6	IL 650
150	160	200	-2/+5	200	200	-	x	-	-	198.0	205	10	IL 310
150	160	225	-1/+19	-	-	244.5	x	6.3	231.9	224.4	244	11	IL 360
150	160	250	-7/+5	250	250	-	x	-	-	242.0	255	9	IL 475
150	160	300	-19/+3	300	300	298.5	x	7.1	284.3	280.0	303	7	IL 500
150	180	225	-2/+5	-	-	-	x	-	-	222.2	230	16	IL 315
150	180	250	-6/+10	250	250	267.0	x	6.3	254.4	244.0	260	12	IL 360
150	180	260	-6/+12	-	-	273.0	x	5.0	263.0	254.0	272	10	IL 410
150	180	310	-1/+13	-	-	323.9	x	5.6	312.7	311.3	323	8	IL 500
200	200	250	-1/+10	250	250	267.0	x	6.3	254.4	248.5	260	9	IL 325
200	200	300	-4/+10	300	300	-	x	-	-	295.1	310	8	IL 440
200	200	310	-9/+6	-	-	323.9	x	5.6	312.7	301.0	316	10	IL 575
200	200	350	-9/+13	350	-	355.6	x	5.6	344.4	339.7	363	8	IL 650
200	200	400	-9/+20	400	-	406.4	x	6.3	393.8	391.5	420	6	IL 700
200	225	265	-4/+5	-	-	273.0	x	5.0	263.0	261.0	270	13	IL 310
200	225	300	-1/+15	300	300	323.9	x	5.6	312.7	299.0	315	12	IL 410
200	225	350	-14/+2	350	-	355.6	x	5.6	344.4	338.3	352	9	IL 525
200	225	400	-9/+16	400	-	406.4	x	6.3	393.8	387.0	416	9	IL 625
200	250	300	-1/+10	300	300	-	x	-	-	298.8	310	11	IL 325
200	250	310	-3/+7	300	-	323.9	x	5.6	312.7	306.0	324	9	IL 425
200	250	350	-12/+5	350	-	355.6	x	5.6	344.4	338.0	360	9	IL 440
200	250	400	-7/+5	400	-	406.4	x	6.3	393.8	388.0	418	9	IL 650
200	250	450	-8/+20	-	-	457.0	x	6.3	444.4	441.0	470	7	IL 700
250	280	320	-4/+5	-	-	-	x	-	-	316.0	325	16	IL 310
250	280	350	-3/+14	350	-	368.0	x	8.0	352.0	347.2	364	18	IL 360
250	280	400	-2/+7	400	-	419.0	x	10.0	399.0	401.8	407	11	IL 525
300	315	355	-4/+5	-	-	-	x	-	-	351.0	360	18	IL 310
300	315	400	-10/+7	400	-	406.4	x	6.3	393.8	390.6	407	12	IL 400
300	315	450	-14/+9	-	-	457.0	x	6.3	444.4	438.4	458	12	IL 500
300	315	500	-9/+13	500	-	508.0	x	6.3	495.4	486.6	511	12	IL 625
350	355	400	-2/+8	400	-	419.0	x	10.0	399.0	398.0	408	31	IL 315
350	355	450	-12/+2	-	-	457.0	x	6.3	444.4	437.0	452	18	IL 475
350	355	500	-5/+5	500	-	-	x	-	-	495.0	505	12	IL 650
350	355	550	-5/+25	-	-	559.0	x	6.3	546.4	545.0	575	9	IL 700
400	400	450	-1/+10	-	-	-	x	-	-	449.7	460	17	IL 325
400	400	470	-1/+14	-	-	-	x	-	-	470.0	484	25	IL 360
400	400	500	-12/+10	500	-	508.0	x	6.3	495.4	488.0	510	14	IL 440
400	400	550	-5/+18	-	-	559.0	x	6.3	546.4	543.5	568	14	IL 650
400	400	600	-9/+20	600	-	610.0	x	6.3	597.4	590.0	620	10	IL 700
450	450	500	-2/+10	500	-	-	x	-	-	498.0	510	19	IL 325
450	450	525	-2/+10	-	-	-	x	-	-	522.0	535	16	IL 400
450	450	550	-4/+10	-	-	559.0	x	6.3	546.4	546.0	560	16	IL 440
450	450	600	-12/+10	600	-	610.0	x	6.3	597.4	588.0	610	15	IL 650
450	450	650	-10/+20	-	-	660.0	x	7.1	645.8	640.0	670	11	IL 700
500	500	550	-1/+10	-	-	-	x	-	-	550.3	560	21	IL 325
500	500	580	-7/+12	-	-	-	x	-	-	572.0	592	18	IL 400
500	500	600	-12/+7	600	-	610.0	x	6.3	597.4	588.0	607	17	IL 440
500	500	650	-5/+10	-	-	660.0	x	7.1	645.8	645.0	660	17	IL 650
500	500	700	-10/+20	700	-	711.0	x	7.1	696.8	690.0	720	12	IL 700
500	560	640	-7/+7	-	-	660.0	x	7.1	645.8	632.0	652	20	IL 400
500	560	650	-2/+20	-	-	-	x	-	-	648.0	670	19	IL 440
500	560	690	-3/+9	-	-	711.0	x	7.1	696.8	692.5	699	20	IL 500
500	560	700	-2/+10	700	-	-	x	-	-	698.0	710	18	IL 650
500	560	750	-21/+8	-	-	762.0	x	8.0	746.0	724.3	756	19	IL 625
600	630	700	-10/+4	700	-	711.0	x	7.1	696.8	686.0	704	22	IL 425
600	630	710	-7/+5	-	-	-	x	-	-	702.0	715	22	IL 400
600	630	750	-0/+7	-	-	-	x	-	-	751.3	757	22	IL 525
600	630	800	-4/+10	800	-	813.0	x	8.0	797.0	792.2	810	21	IL 625
600	670	750	-5/+12	-	-	762.0	x	8.0	746.0	745.0	762	24	IL 400
600	670	800	-9/+13	800	-	813.0	x	8.0	797.0	790.0	813	23	IL 500
600	670	850	-14/+10	-	-	864.0	x	8.8	846.4	832.0	860	22	IL 625

For more combinations see our calculation program



# Pressio®-Elements 4 pipes Selection Guide for Pipe OD



Selection guide for steel and stainless steel pipes acc. DIN 2448 / 2458													
carrier pipe OD Ø DN	mm	core drilled hole recomm. ID Ø mm	tolerance	wall sleeve fibre cement ID Ø mm	wall sleeve PVC ID Ø mm	wall sleeve steel ID Ø mm				core hole mm		Pressio® Elements number of elements	Type
						Ø a	x	s	Ø i	min.	max.		
10	17.2	50	-1/+6	-	50	-	x	-	-	49.2	56	4	IL 275
15	21.3	50	-0/+2	-	50	-	x	-	-	50.3	52.7	4	IL 200
20	26.9	50	-2/+2	-	50	-	x	-	-	48.1	51.9	4	IL 100
	26.9	80	-2/+10	80	80	88.9	x	2	84.9	77.9	90	4	IL 340
25	33.7	60	-1/+5	-	60	63.5	x	2	59.5	59.7	65.1	5	IL 200
	33.7	70	-4/+2	-	70	-	x	-	-	65.7	72	6	IL 275
32	42.4	80	-0/+2	80	80	-	x	-	-	80.6	82.4	8	IL 275
	42.4	100	-6/+2	100	100	101.6	x	2	97.6	93.4	102	5	IL 340
40	48.3	70	-2/+3	-	70	-	x	-	-	67.8	73.3	6	IL 100
	48.3	100	-6/+0	100	100	101.6	x	2	97.6	93.8	100	6	IL 315
	48.3	125	-6/+5	125	125	133.0	x	2	129.0	119.2	132.3	5	IL 360
50	60.3	80	-1/+5	80	80	88.9	x	2	84.9	78.3	85.3	7	IL 100
	60.3	100	-4/+5	100	100	101.6	x	2	97.6	96.3	105	6	IL 300
	60.3	125	-0/+8	125	125	133.0	x	2	129.0	124.3	133.8	5	IL 360
65	76.1	100	-2/+1	100	100	101.6	x	2	97.6	97.4	101.1	9	IL 100
	76.1	125	-6/+3	125	125	-	x	-	-	118.3	128.1	8	IL 315
	76.1	150	-9/+5	150	150	-	x	-	-	140.1	155	6	IL 360
80	88.9	125	-4/+3	125	125	-	x	-	-	120.9	128.9	8	IL 265
	88.9	125	-0/+8	125	125	133.0	x	2	129.0	125.0	133	8	IL 300
	88.9	150	-6/+6	150	150	-	x	-	-	143.6	156.9	9	IL 340
100	114.3	150	-4/+4	150	150	159.0	x	4.5	150.0	146.3	154.3	10	IL 265
	114.3	150	-0/+9	150	150	159.0	x	4.5	150.0	150.0	159	7	IL 310
	114.3	200	-3/+11	200	200	-	x	-	-	196.3	211	7	IL 475
	114.3	225	-2/+5	-	-	-	x	-	-	222.7	230.3	7	IL 575
125	139.7	200	-3/+7	200	200	-	x	-	-	196.3	207.7	13	IL 340
	139.7	210	-4/+13	-	-	219.1	x	3	213.1	206.9	223.7	10	IL 360
	139.7	225	-3/+11	-	-	-	x	-	-	221.7	236.7	8	IL 475
	139.7	250	-2/+5	250	250	256.0	x	3	250.0	247.9	255.7	8	IL 575
	139.7	300	-22/+4	300	300	-	x	-	-	277.7	304	6	IL 650
150	168.3	210	-5/+3	-	-	219.1	x	3	213.1	205.0	213.3	10	IL 310
	168.3	225	-3/+10	-	-	-	x	-	-	222.7	236.3	15	IL 340
	168.3	250	-8/+10	250	250	256.0	x	3	250.0	242.4	260.3	7	IL 400
	168.3	300	-11/+10	300	300	298.5	x	3	292.5	288.3	310	7	IL 500
200	219.1	260	-4/+4	-	-	-	x	-	-	256.0	264.1	13	IL 310
	219.1	300	-5/+14	300	300	-	x	-	-	294.5	316.1	12	IL 410
	219.1	350	-8/+11	350	-	355.6	x	3	349.6	343.1	362.1	9	IL 500
	219.1	400	-12/+17	400	-	406.4	x	4	398.4	388.0	417	9	IL 625
250	273	310	-0/+8	-	-	323.9	x	3	317.9	309.0	318	16	IL 310
	273	340	-3/+6	-	-	-	x	-	-	337.0	346	17	IL 360
	273	350	-3/+5	350	-	355.6	x	3	349.6	347.0	354	14	IL 410
	273	400	-6/+5	400	-	406.4	x	4	398.4	393.0	405	10	IL 500
	273	450	-12/+16	-	-	457.0	x	4	449.0	435.0	466	7	IL 615
300	323.9	400	-3/+13	400	-	419.0	x	4	411.0	395.9	415	12	IL 400
	323.9	400	-11/+6	400	-	406.4	x	4	398.4	387.9	407.9	20	IL 360
	323.9	450	-6/+13	-	-	457.0	x	4	449.0	443.9	463	12	IL 500
	323.9	500	-10/+15	500	-	508.0	x	4	500.0	490.0	515	12	IL 625
350	355.6	400	-1/+7	400	-	-	x	-	-	399.4	407.6	31	IL 315
	355.6	450	-10/+2	-	-	457.0	x	4	449.0	437.6	452	18	IL 475
	355.6	490	-14/+8	-	-	488.0	x	4	480.0	475.6	498.6	13	IL 500
	355.6	500	-6/+5	500	-	508.0	x	4	500.0	493.6	505	12	IL 650
	355.6	550	-4/+25	-	-	559.0	x	6,3	546.4	545.6	575.6	9	IL 700
400	406.4	500	-5/+10	500	-	508.0	x	4	500.0	495.0	510	14	IL 440
	406.4	550	-5/+15	-	-	559.0	x	4	551.0	544.4	565	14	IL 650
	406.4	600	-3/+26	600	-	610.0	x	5	600.0	596.4	626.4	10	IL 700
450	457	510	-6/+7	-	-	-	x	-	-	503.4	517	19	IL 325
	457	550	-4/+17	-	-	559.0	x	4	551.0	546.0	567	16	IL 440
	457	600	-5/+5	600	-	610.0	x	5	600.0	595.0	605	15	IL 650
	457	650	-24/+5	-	-	660.0	x	5	650.0	626.0	655	16	IL 625
500	508	560	-5/+8	-	-	-	x	-	-	554.4	568	21	IL 325
	508	600	-3/+10	600	-	610.0	x	5	600.0	597.0	610	17	IL 440
	508	650	-4/+10	-	-	660.0	x	5	650.0	646.0	660	17	IL 650
	508	700	-6/+6	700	-	711.0	x	5	701.0	694.0	704	18	IL 625
550	559	610	-4/+9	-	-	-	x	-	-	605.4	619	23	IL 325
	559	650	-3/+19	-	-	660.0	x	5	650.0	647.0	669	19	IL 440
	559	700	-3/+10	700	-	711.0	x	5	701.0	697.0	710	18	IL 650
	559	750	-22/+7	-	-	762.0	x	5	752.0	724.3	755	19	IL 625
600	610	660	-3/+10	-	-	-	x	-	-	656.4	670	25	IL 325
	610	700	-7/+7	700	-	711.0	x	5	701.0	694.8	707	30	IL 475
	610	750	-1/+28	-	-	762.0	x	5	752.0	748.0	778	20	IL 650
	610	800	-4/+8	800	-	813.0	x	5	803.0	792.2	806	21	IL 625

For more combinations see our calculation program

# Pressio®-Elements 4 pipes Selection Guide for Pipe OD



## Selection guide for steel pipes acc. DIN 2448 / 2458 with PE-coating (standard) acc. DIN 30670

carrier pipe OD Ø	core drilled hole recomm. ID Ø mm	tolerance	wall sleeve fibre cement ID Ø mm	wall sleeve PVC ID Ø mm	wall sleeve steel ID Ø mm				core hole mm		Pressio® Elements number of elements	Type	
					Ø a	x	s	Ø i	min.	max.			
10	20.8	50	-0/+2	-	50	-	x	-	-	50.3	52.2	4	IL 200
15	24.9	50	-0/+6	-	50	-	x	-	-	50.3	56.3	4	IL 200
	24.9	60	-3/+3	-	60	63.5	x	2.3	58.9	56.9	63.5	5	IL 275
20	30.5	50	-1/+5	-	50	-	x	-	-	48.5	55.5	4	IL 100
	30.5	60	-1/+2	-	60	63.5	x	2.3	58.9	59.8	61.9	5	IL 200
25	37.3	100	-9/+5	100	100	101.6	x	2.9	95.8	90.9	105.3	5	IL 340
32	46.0	70	-2/+1	-	70	76.1	x	2.6	70.9	67.8	71	6	IL 100
	46.0	80	-1/+6	80	80	88.9	x	2.9	83.1	80.6	86	8	IL 275
	46.0	100	-3/+6	100	100	108.0	x	2.9	102.2	97.0	114	5	IL 340
40	51.9	70	-0/+6	-	70	76.1	x	2.6	70.9	69.9	76.9	6	IL 100
	51.9	80	-1/+3	80	80	88.9	x	2.9	83.1	78.9	83.3	7	IL 200
	51.9	100	-5/+3	100	100	101.6	x	2.9	95.8	94.1	103.9	6	IL 315
50	51.9	125	-6/+9	125	125	133.0	x	3.6	125.8	119.2	135.9	5	IL 360
	63.9	100	-1/+5	100	100	108.0	x	2.9	102.2	99.9	105	6	IL 300
	63.9	125	-8/+6	125	125	133.0	x	3.6	125.8	117.2	131.9	7	IL 340
65	63.9	150	-7/+8	150	150	159.0	x	4.0	151.0	143.9	160.9	5	IL 410
	79.7	100	-2/+4	100	100	108.0	x	2.9	102.2	97.7	104.7	9	IL 100
	79.7	125	-6/+5	125	125	133.0	x	3.6	125.8	121.9	130	8	IL 315
80	79.7	150	-5/+5	150	150	159.0	x	4.0	151.0	143.7	163.7	6	IL 360
	92.5	125	-0/+7	125	125	133.0	x	3.6	125.8	125.0	132	8	IL 265
	92.5	150	-6/+9	150	150	159.0	x	4.0	151.0	143.6	157.5	9	IL 340
100	117.9	150	-0/+6	150	150	159.0	x	4.0	151.0	149.9	156	10	IL 265
	117.9	160	-0/+2	-	-	168.3	x	4.0	160.3	160.0	162	11	IL 300
	117.9	200	-8/+11	200	200	219.1	x	4.5	210.1	191.9	206.5	7	IL 410
	117.9	225	-2/+8	-	-	244.5	x	6.3	231.9	222.7	233.9	7	IL 575
125	143.7	200	-4/+11	200	200	-	x	-	-	196.3	211.7	13	IL 340
	143.7	210	-2/+11	-	-	219.1	x	4.5	210.1	207.7	227.7	10	IL 360
	143.7	225	-8/+10	-	-	244.5	x	6.3	231.9	215.7	235.7	6	IL 400
	143.7	250	-2/+9	250	250	267.0	x	6.3	254.4	247.9	259.7	8	IL 575
150	143.7	300	-18/+3	300	300	-	x	-	-	281.7	303	6	IL 650
	172.3	210	-1/+5	-	-	219.1	x	4.5	210.1	209.0	215	10	IL 310
	172.3	225	-1/+14	-	-	244.5	x	6.3	231.9	223.3	236	15	IL 340
	172.3	250	-5/+14	250	250	267.0	x	6.3	254.4	244.3	264.3	7	IL 400
	172.3	300	-7/+5	300	300	-	x	-	-	292.3	305	7	IL 500
200	172.3	320	-9/+10	-	-	323.9	x	5.6	312.7	310.3	330	7	IL 650
	223.1	260	-0/+8	-	-	273.0	x	5.0	263.0	259.1	268.1	13	IL 310
	223.1	300	-3/+17	300	300	323.9	x	5.6	312.7	297.1	320.1	12	IL 410
	223.1	350	-6/+15	350	-	355.6	x	5.6	344.4	343.1	366.1	9	IL 500
	223.1	400	-10/+20	400	-	406.4	x	6.3	393.8	390.0	420	9	IL 625
250	277.0	330	-4/+7	-	-	-	x	-	-	324.0	337	12	IL 325
	277.0	340	-6/+8	-	-	355.6	x	5.6	344.4	333.0	351	10	IL 425
	277.0	350	-3/+11	350	-	368.0	x	8.0	352.0	347.2	361	18	IL 360
	277.0	380	-5/+13	-	-	-	x	-	-	374.1	393	13	IL 575
	277.0	400	-1/+4	400	-	419.0	x	10.0	399.0	401.8	404	11	IL 525
300	277.0	450	-10/+12	-	-	457.0	x	6.3	444.4	439.0	462	7	IL 615
	328.3	400	-8/+5	400	-	406.4	x	6.3	393.8	392.3	405	20	IL 360
	328.3	410	-7/+15	-	-	-	x	-	-	402.3	425.3	17	IL 410
	328.3	450	-11/+5	-	-	457.0	x	6.3	444.4	438.3	455.3	12	IL 525
	328.3	500	-5/+20	500	-	508.0	x	6.3	495.4	490.3	520	12	IL 625
350	360.0	410	-4/+10	-	-	-	x	-	-	406.4	420	15	IL 325
	360.0	450	-7/+5	-	-	457.0	x	6.3	444.4	442.0	455	18	IL 475
	360.0	490	-9/+6	-	-	508.0	x	6.3	495.4	480.0	496	13	IL 500
	360.0	550	-24/+8	-	-	559.0	x	6.3	546.4	522.0	558	13	IL 625
400	410.8	460	-2/+10	-	-	-	x	-	-	457.2	470.8	17	IL 325
	410.8	500	-5/+7	500	-	508.0	x	6.3	495.4	495.0	507.8	21	IL 475
	410.8	550	-18/+3	-	-	559.0	x	6.3	546.4	533.7	553.8	15	IL 500
	410.8	600	-8/+8	600	-	610.0	x	6.3	597.4	592.0	608	15	IL 625
450	461.4	510	-2/+11	-	-	-	x	-	-	507.8	521.4	19	IL 325
	461.4	550	-6/+5	-	-	559.0	x	6.3	546.4	543.4	555.5	23	IL 475
	461.4	600	-7/+4	600	-	610.0	x	6.3	597.4	597.2	604.4	17	IL 500
	461.4	650	-22/+9	-	-	660.0	x	7.1	645.8	623.4	657.4	16	IL 625
500	513.0	560	-0/+13	-	-	-	x	-	-	559.4	573	21	IL 325
	513.0	600	-5/+5	600	-	610.0	x	6.3	597.4	595.0	605	25	IL 475
	513.0	650	-17/+2	-	-	660.0	x	7.1	645.8	633.0	652.5	18	IL 500
	513.0	700	-6/+11	700	-	711.0	x	7.1	696.8	694.0	709	18	IL 625
550	564.0	620	-9/+4	-	-	-	x	-	-	610.4	624	23	IL 325
	564.0	640	-3/+10	-	-	660.0	x	7.1	645.8	636.0	650	20	IL 400
	564.0	650	-2/+11	-	-	-	x	-	-	651.1	661	28	IL 475
	564.0	700	-12/+7	700	-	711.0	x	7.1	696.8	692.5	707	20	IL 500
	564.0	750	-20/+12	-	-	762.0	x	8.0	746.0	726.0	762	19	IL 625
600	615.0	700	-12/+7	700	-	711.0	x	7.1	696.8	687.0	707	22	IL 400
	615.0	750	-14/+5	-	-	762.0	x	8.0	746.0	735.0	755	21	IL 500
	615.0	800	-4/+13	800	-	813.0	x	8.0	797.0	792.2	813	21	IL 625

For more combinations see our calculation program

# Pressio®-Elements 4 pipes Selection Guide for Pipe OD

## Selection guide for ductile iron pipes (GGG) acc. to EN 545, EN 598

carrier pipe OD Ø		core drilled hole recomm. ID Ø mm	tolerance	wall sleeve fibre cement ID Ø mm	wall sleeve PVC ID Ø mm	wall sleeve steel ID Ø mm				core hole mm		Pressio® Elements number of elements	Type
DN	mm					Ø a	x	s	Ø i	min.	max.		
80	98	140	-5/+3	-	-	-	x	-	-	134.9	143	9	IL 300
	98	150	-1/+4	150	150	159.0	x	4.0	151.0	149.0	154	9	IL 340
100	118	150	-0/+6	150	150	159.0	x	4.0	151.0	150.0	156	10	IL 265
	118	160	-0/+3	-	-	168.3	x	4.0	160.3	161.0	163	11	IL 300
	118	200	-8/+4	200	200	-	x	-	-	192.0	204	7	IL 410
	118	225	-2/+9	-	-	244.5	x	6.3	231.9	222.7	234	7	IL 575
125	144	200	-4/+12	200	200	219.1	x	4.5	210.1	196.3	212	13	IL 340
	144	210	-2/+18	-	-	219.1	x	4.5	210.1	208.0	228	10	IL 360
	144	225	-8/+11	-	-	244.5	x	6.3	231.9	216.0	236	6	IL 400
	144	250	-2/+10	250	250	267.0	x	6.3	254.4	247.9	260	8	IL 575
150	170	210	-4/+5	-	-	219.1	x	4.5	210.1	206.0	215	10	IL 310
	170	225	-3/+13	-	-	244.5	x	6.3	231.9	222.7	238	15	IL 340
	170	250	-7/+12	250	250	267.0	x	6.3	254.4	242.4	262	7	IL 400
	170	300	-9/+5	300	300	-	x	-	-	290.0	305	7	IL 500
200	222	260	-2/+7	-	-	273.0	x	5.0	263.0	258.0	267	13	IL 310
	222	300	-4/+19	300	300	323.9	x	5.6	312.7	296.0	319	12	IL 410
	222	350	-7/+15	350	-	355.6	x	5.6	344.4	343.1	365	9	IL 500
	222	400	-11/+20	400	-	406.4	x	6.3	393.8	384.7	420	9	IL 625
250	274	315	-5/+4	-	-	323.9	x	5.6	312.7	310.0	319	16	IL 310
	274	340	-6/+4	-	-	355.6	x	5.6	344.4	338.0	346	17	IL 360
	274	350	-2/+5	350	-	368.0	x	8.0	352.0	348.0	355	14	IL 410
	274	400	-5/+5	400	-	419.0	x	10.0	399.0	394.0	405	10	IL 500
	274	450	-12/+16	-	-	457.0	x	6.3	444.4	436.0	466	7	IL 615
300	326	380	-4/+6	-	-	-	x	-	-	374.3	386	14	IL 325
	326	400	-1/+15	400	-	419.0	x	10.0	399.0	398.0	415	12	IL 400
	326	450	-13/+3	-	-	457.0	x	6.3	444.4	436.0	453	12	IL 525
	326	500	-8/+15	500	-	508.0	x	6.3	495.4	488.0	515	12	IL 625
350	378	450	-8/+2	-	-	457.0	x	6.3	444.4	442.0	452	23	IL 360
	378	500	-1/+21	500	-	-	x	-	-	501.9	521	14	IL 500
	378	500	-6/+5	500	-	508.0	x	6.3	495.4	497.1	505	14	IL 525
	378	550	-8/+10	-	-	559.0	x	6.3	546.4	540.0	560	9	IL 615
400	429	480	-3/+9	-	-	-	x	-	-	477.0	489	18	IL 325
	429	500	-0/+7	500	-	-	x	-	-	500.0	507	16	IL 425
	429	510	-1/+11	-	-	-	x	-	-	509.2	521	16	IL 400
	429	540	-1/+10	-	-	559.0	x	6.3	546.4	539.0	550	15	IL 525
	429	550	-1/+5	-	-	-	x	-	-	549.0	555	15	IL 500
500	532	600	-5/+20	600	-	610.0	x	6.3	597.4	591.0	620	15	IL 625
	532	600	-10/+6	600	-	610.0	x	6.3	597.4	590.1	606	19	IL 425
	532	610	-5/+14	-	-	-	x	-	-	604.0	624	19	IL 400
	532	640	-12/+8	-	-	660.0	x	7.1	645.8	628.0	648	23	IL 575
	532	650	-0/+9	-	-	-	x	-	-	650.0	659	19	IL 525
600	635	700	-2/+25	700	-	-	x	-	-	694.0	725	18	IL 625
	635	700	-8/+5	700	-	711.0	x	7.1	696.8	691.0	705	22	IL 425
	635	750	-5/+12	-	-	762.0	x	8.0	746.0	751.3	762	22	IL 525
	635	800	-3/+20	-	-	-	x	-	-	797.0	820	21	IL 625

For more combinations see our calculation program

The 4 pipes warranty only applies to faulty material. Checking the suitability of the product for the individual application is solely the responsibility of the user.



# Pressio®-Elements Modular Wall Penetration Seals 4 pipes



## Please consider the following points before installation:

- Carrier pipe must be **centred and supported**, especially before back filling. Pressio®-Elements seals cannot provide any load-bearing function and are not a fixed point.
- Core holes can be coated with epoxy resin 4 pipes to protect the concrete surface and reinforcing steel. The coating can also smoothen over any cavities and grooves.
- Remove dirt** and impurities from carrier pipe and core bore / wall sleeve.
- It is not possible to seal a spiral-wave pipe in this way.



### Attention! Only for type KTW/W270:

Use the supplied lubricant on the inside and outside surfaces of each joint, as well as the connected ends, so the elements can glide.



1. **Connect ends of the Pressio®-Elements and adjust pressure plates.** All bolt heads have to face out towards the installation technician.



Installation video



2. It is possible that a chain could slightly sag. **Elements must not be removed from the chain.** The correct number of elements has to be installed as specified. It can be necessary to stretch the chain for smaller pipe diameters.



3. Push Pressio®-Elements **into the annular space.** Begin to push in the seal first at 6 o'clock position, then right and left up to the 12 o'clock position. The bolt heads should still be easily accessible after positioning in the wall.



4. Tighten the bolts with a **torque wrench**, beginning at the 12 o'clock position. Do not tighten with a power tool! Tighten each bolt with about 4 to 5 turns. Repeat **in clockwise direction** until the noted torque (see table) is reached and the rubber is squeezed out evenly between the pressure plates.



5. **Tighten the bolts again after about 2 hours**, in accordance with the torque table below. Repeat this procedure several times depending on on-site conditions (e.g. temperatures < 10°C, larger annual space etc.). This is important, especially for IL 500 and larger.

Torque Table			
Type		Type: C, S 316, OC, OS 316, KTW/W270 and TS	Type: BC and BS 316
IL 100	M4	1 Nm	1 Nm
IL 200 up to IL 275	M5	1.5 Nm	1 Nm
IL 300 up to IL 360	M6	5 Nm	4 Nm
IL 400 up to IL 475	M8	15 Nm	12 Nm
IL 500 up to IL 575	M10	30 Nm	22 Nm
IL 615 up to IL 700	M12	60 Nm	48 Nm

e.g. Tightening torque depending on the temperature

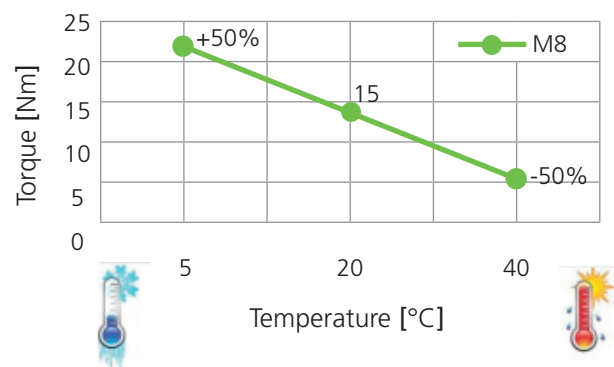

To select the right Pressio®-Elements and calculate how many you need for your project, please refer to the calculation program on our website: [www.4pipes.de](http://www.4pipes.de)



Pipeline Accessories

## Rubber Support and Cover Rings 4 pipes



## Rubber Support Ring 4 pipes

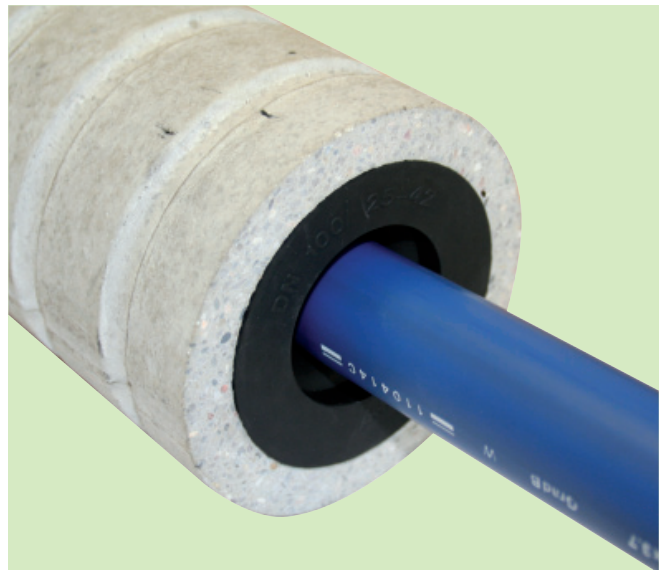

### Product information

Rubber support rings and cover rings are made to protect the annular space between pipe and wall from dirt and moisture inside the building. The rubber ring is made of high quality elastomer. The conical seal is just pressed into the annular space by hand.

A special sealing membrane adjusts to various pipe dimensions perfectly and seals against external moisture.

An integrated O-ring in the membrane optimises the sealing function to the pipe and the stability of the seal. The seal is designed for usage in all common wall sleeves of PVC or fibre cement as well as the flexible casing pipes, used in house-entry technology. The conical outside shape adapts the seal to various different casing pipes.

Ø ID or wall sleeve	Ø Carrier pipe in mm	Art.-No.
ID 70	18-32	13040
ID 70	40	13039
ID 80	25-42	13041
ID 80	45-52	13042
ID 90	25-42	13043
ID 90	42-54	13044
ID 99-103.6	20-25	13045
ID 99-103.6	32-40	13046
ID 99-103.6	40-56	13047
ID 99-103.6	56-66	13048

The 4 pipes warranty only applies to faulty material. Checking the suitability of the product for the individual application is solely the responsibility of the user.



## Conical Sealing Plug 4 pipes

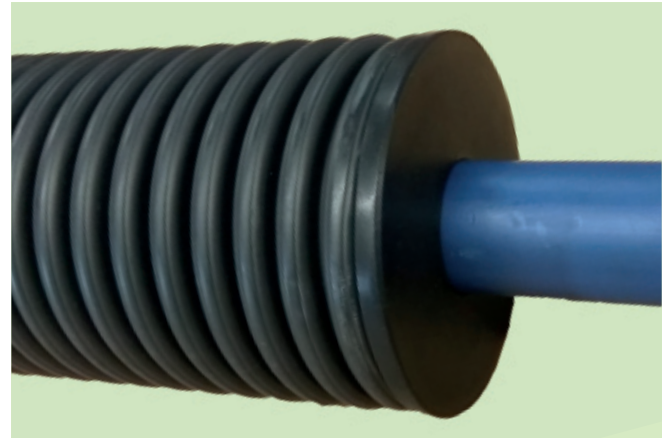
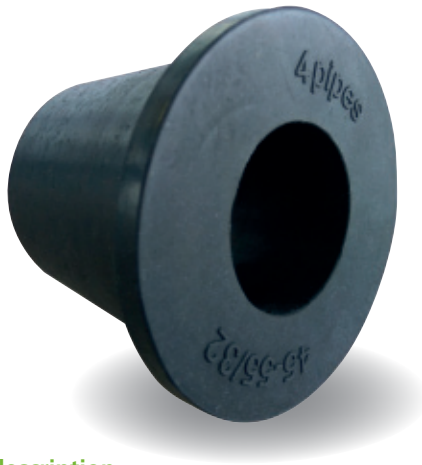

### Product description

**Conical Sealing Plugs 4 pipes** are designed to seal small diameter pipes and cables in casing pipes against sand and moisture at the open end of the casing. Casing can be e.g. flexible or PVC pipes or core drilled holes.

The **Conical Sealing Plug 4 pipes** is designed to seal against low external water pressure. A collar on the wide side makes handling easy and serves as a stop. The extra soft EPDM material  $40 \pm 5$  Shore A makes the application safe and easy. The plug **can be cut to be used as an open product for retrofit applications.**

### Standard sizes

For casing ID in mm	For carrier pipe OD in mm	Fits for cable casing DN (DA) (corrugated pipe)	Description	Art.-No.
37 - 43	Blind	50 / 50	37 - 43 / 0	12940
	32		37 - 43 / 32	12941
45 - 55	Blind	63 / 64	45 - 55 / 0	12945
	32		45 - 55 / 32	12946
	40		45 - 55 / 40	12947
54 - 64	Blind	75 / 76	54 - 64 / 0	12950
	32		54 - 64 / 32	12951
	40		54 - 64 / 40	12952
	50		54 - 64 / 50	12953
62 - 72	Blind	90 / 91	62 - 72 / 0	12955
	32		62 - 72 / 32	12956
	40		62 - 72 / 40	12957
	50		62 - 72 / 50	12958
70 - 80	Blind	90 / 91	70 - 80 / 0	12960
	32		70 - 80 / 32	12961
	40		70 - 80 / 40	12962
	50		70 - 80 / 50	12963
	63		70 - 80 / 63	12964
	32* + 12*		70 - 80 / 32 + 1x12	12965
	*Ø32 and Ø12 with blind plugs preassigned			
85 - 95	Blind	110 / 111	85 - 95 / 0	12970
	32		85 - 95 / 32	12971
	40		85 - 95 / 40	12972
	50		85 - 95 / 50	12973
	63		85 - 95 / 63	12974
96 - 106	Blind	120 / 118	96 - 106 / 0	12980
	32		96 - 106 / 32	12981
	40		96 - 106 / 40	12982
	50		96 - 106 / 50	12983
	63		96 - 106 / 63	12984
	32 + 2x7*		96 - 106 / 32 + 2x7	12986
	*2x Ø7 with blind plugs preassigned			
	40* + 1x12*		96 - 106 / 40 + 1x12	12987
*Ø40 and Ø12 with blind plugs preassigned				

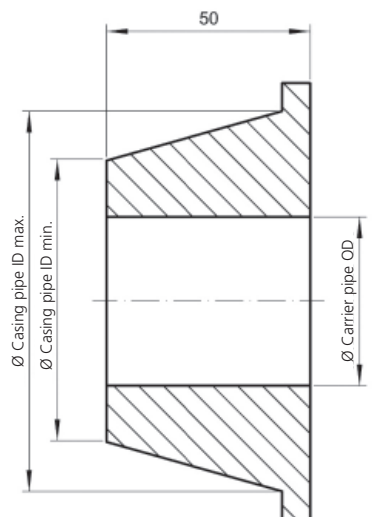

The 4 pipes warranty only applies to faulty material. Checking the suitability of the product for the individual application is solely the responsibility of the user.

## Conical Sealing Plug 4 pipes



### Application

The **Conical Sealing Plug** needs to be pulled over the pipe before insertion. Lubricant helps to slide the pipe through. When the carrier pipe is in its final position, the plug is pushed into the annular space by hand. The plug can be lightly hammered into its final position. Do not smash the plug collar into the casing.

### Material

Rubber: EPDM black  
Durometer: 40  $\pm$ 5 Shore A (extra soft)  
Height incl. collar: 50 mm

Other material qualities on request.

All plug sizes can be cut on-site using a sharp knife to allow retrofit application. One cut is enough.

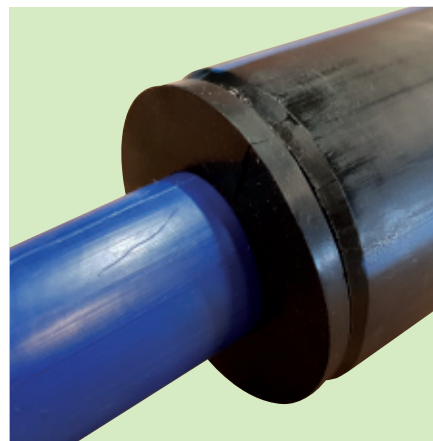



Pipeline Accessories

Manhole Connector  
4 pipes

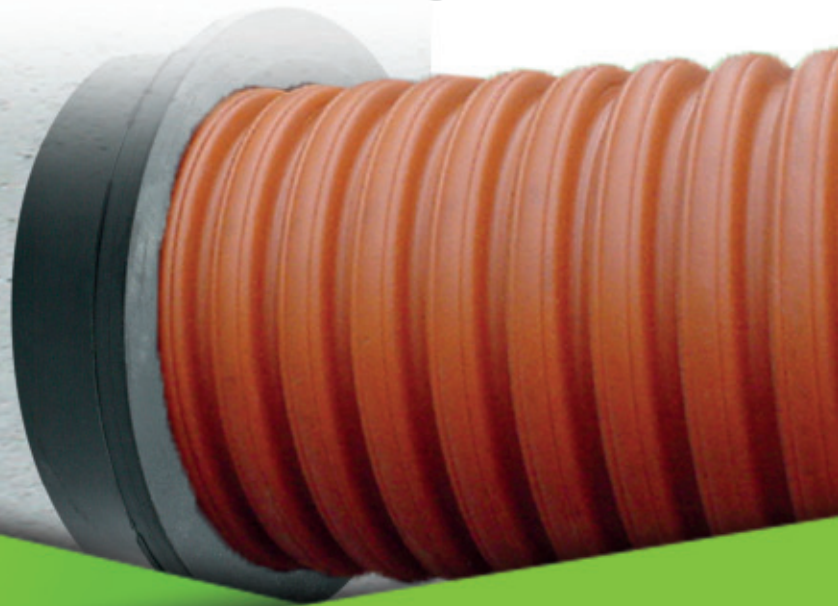



# Manhole Connector 4 pipes - Type P-MC

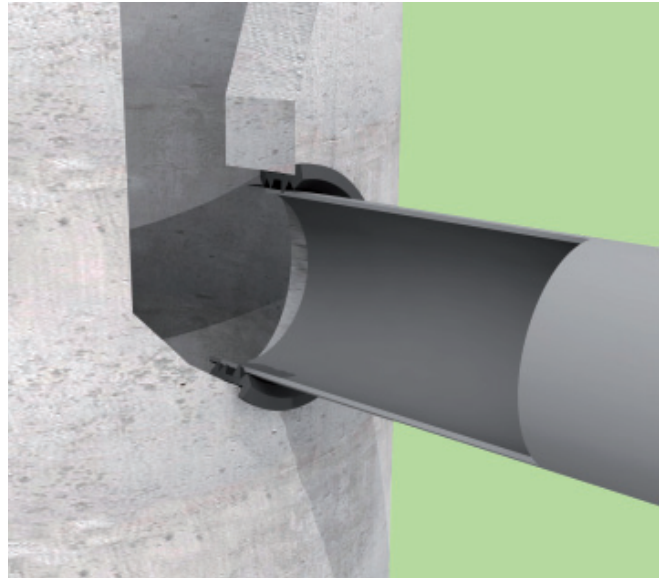

### Product information

The sealing rings for the connection of plastic pipelines to manholes are made for a safe seal inside the annular space between core drilled hole and carrier pipe.

Manhole Connectors 4 pipes are made from high quality EPDM elastomer durometer 50 Shore A, acc. to EN681, to guarantee a long life-time.

Please see the available combinations of manhole and pipe diameters.

### Installation instruction

1. Drilling - Drill the concrete or plastic wall with the core drill in specified dimension. Deburr the hole edges.
2. Mark the insertion depth of the seal on the pipe for subsequent checking of optimal installation. If possible, use lubricant when inserting the seal and the pipe.

### PLAIN Manhole Connector Type P-MC

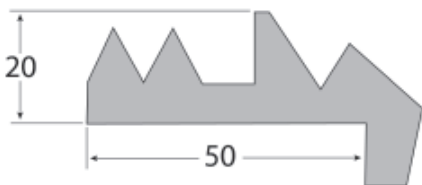

Other profiles on request

Pipe OD	Ø Drill hole	Art.No.
110	138 mm	22900
125	151 mm	22901
160	186 mm	22902
200	226 mm	22903
250	276 mm	22904
315	341 mm	22905
400	426 mm	22906
500	526 mm	22907
630	656 mm	22908



Pipeline Accessories

Aqua Stopper  
Pipeline Closure Plugs  
4 pipes

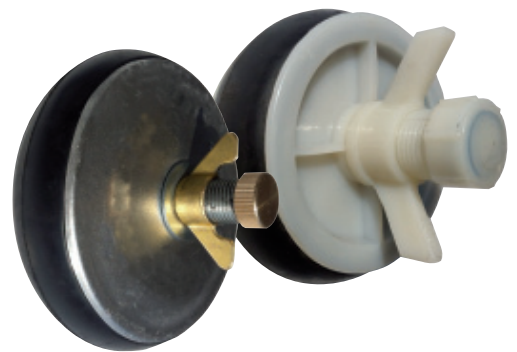



**Aqua Stopper pipeline closure and testing plugs allow pipe ends to be sealed quickly and securely.**

## The Product

Aqua Stopper pipeline closure plugs are mainly designed to **seal open pipe ends** on pipelines of all kinds. The Aqua Stopper plugs are also made for **pressure testing** of pipeline parts with water or air.

The sealing element of the Aqua Stopper plugs is expanded and activated by turning the wingnut at the front on the outlet thread. The outlet with the integrated thread is designed for filling, emptying and pressure testing the pipeline.

## Applications

- Overnight pipe capping
- Repair
- Pressure testing
- Manhole inspection
- Cleaning and flushing
- General pipeline installation
- Temporary closure for wall penetrations

## For pipelines made of:

- Steel
- Plastic
- Ductile iron
- Clay
- Pipes with inner coatings

## Advantages

- Quick and easy application
- Reusable many times
- Secure seal for pressure test with water or air
- Tight up to 1.5 bar with an applied holding fixture – depending on pipe size
- 2 in 1 = Sealing as well as filling and testing options
- Reasonably priced





**Aqua Stopper closes core drilled hole**



# Aqua Stopper Pipeline Closure Plugs 4 pipes

## Technical Data

Nylon Edition				
				
Sealing range		Article No.	Max. water pressure* in bar	Thread size (Inch)
Min. pipe ID in mm	Max. pipe ID in mm			
48.5	62	13920	1	1/2
74	86	13921	1	1/2
95.5	105	13922	0.3	1/2

Aluminium Edition				
				
Sealing range		Article No.	Max. water pressure* in bar	Thread size (Inch)
Min. pipe ID in mm	Max. pipe ID in mm			
38	50	13930	1.5	1/2
49	62	13931	1.5	1/2
62	77	13932	1.5	1/2
73	89	13933	1	1/2
84	103	13934	1	1/2
94	110	13935	0.5	1/2
112	130	13936	0.5	1/2
125	142	13937	0.5	1/2
146	168	13938	0.5	1/2
175	200	13939	0.5	1
193	220	13940	0.5	1
220	240	13941	0.5	1
245	270	13942	0.5	1
277	328	13943	0.5	1
295	325	13944	0.5	1
325	360	13945	0.3	1
350	385	13946	0.3	1
370	410	13947	0.3	1
390	435	13948	0.3	1
445	495	13949	0.3	2
495	550	13950	0.2	2
595	650	13951	0.2	2

\*with additional holding fixture

## Application

For a perfect function of the Aqua Stopper please consider the following points:

1. The pipeline inner diameter must fit to the sealing range of the chosen model.
2. Clean the stopper before and after application.
3. The Aqua Stopper should be positioned at a right angle to the pipe, close to the pipe end.
4. Close wingnut.
5. For a pressure test we strongly recommend a separate holding fixture for sealing and safety reasons.

The 4 pipes warranty only applies to faulty material. Checking the suitability of the product for the individual application is solely the responsibility of the user.



Pipeline Accessories

Compenseal<sup>®</sup>,  
Sealing Sleeves Type KMR  
4 pipes





**1 bar**  
with load cycles  
MFPA tested



### Product information

Special flexible sealing collar made out of high quality **EPDM elastomer** for wall penetrations at pipelines which are exposed to movements. The seal is extremely suitable for axial and radial pipe movement as well as any subsidence or sagging, and it is tight against high external water pressure.

### Usage

As a movement compensator, the sealing collar is perfectly suited for **preinsulated pipe** penetration through walls and ceilings on buildings.

- Water pressure tight up to 1.0 bar

### Advantages

- suitable for axial and radial pipe movement up to +/- 40 mm
- suitable in case of subsidence or sagging, depending on outside pipe diameter and core hole sizes up to 40 mm
- ideal movement compensator

### Dimensions

Standard for outside pipe diameter 75 mm **up to 800 mm** and core bores 150 mm up to 900 mm.

### Complete Set:

The seal is supplied with one component PU sealant, stainless steel straps, 12 mm stainless steel hexhead screws and 14 mm dowels as a complete set.

The 4 pipes warranty only applies to faulty material. Checking the suitability of the product for the individual application is solely the responsibility of the user.

### Dimensions 4 pipes Compenseal

HDPE jacket outer diameter in mm	max. core drilled hole Ø mm	OD wall flange mm	Art.-No.
KMR OD 75-90-110	150 / 200	350	20050
KMR OD 125-140-160	200 / 250	400	20051
KMR OD 180-200-225	300	450	20052
KMR OD 250-280-315	350 / 400	565	20053
KMR OD 355-400	450 / 500	650	20054
KMR OD 450-500	550 / 600	750	20055
KMR OD 560-630	650 / 700	880	20056
KMR OD 670	800	1050	20058
KMR OD 710-800	800 / 900	1050	20057

Other dimensions on request



4 pipes stainless steel straps used for pipe sizes up **OD 315 mm**  
Torque value 10 Nm



4 pipes stainless steel strap width 20 mm for pipe size **OD 75 mm up to 280 mm**, Torque value 10 Nm

### Product Data

Material	EPDM
Pressure plate	stainless steel V2A
Operating temperature	120°C
Thickness	8 mm ± 1 mm
Durometer Shore A	60 ± 5
Elongation at break	400%



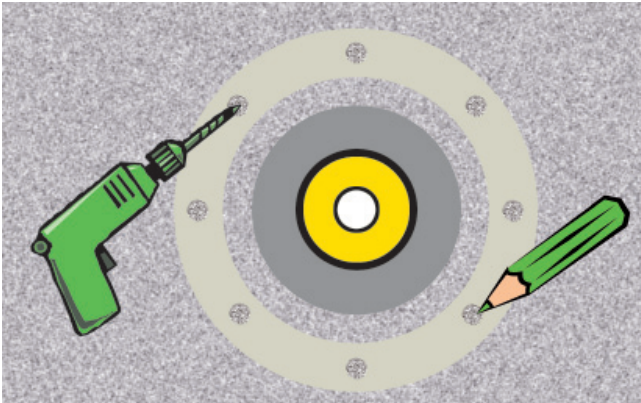

1. Centre and support **carrier pipe in** core bore.
2. Apply pressure plate centered to core bore and mark **boreholes** at wall/ceiling. After that **drill** into marks and **put dowel inside**.

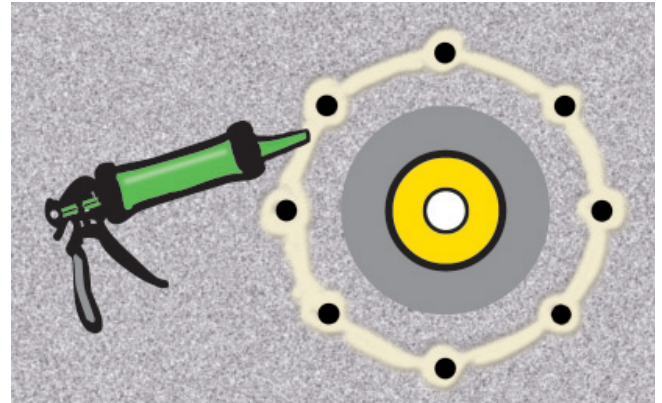

3. Apply **sealing compound** material on the wall with a dispensing gun in a circle around every screw bore as well as the complete core bore range.

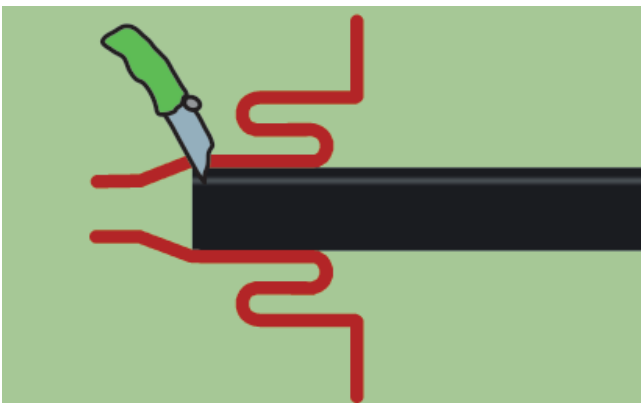

4. **If necessary, cut down the seal nozzle to the correct pipe dimension.**  
Pull Compenseal® over the pipe's end and cut off the seal with a sharp knife along the edge.  
**The edges in the nozzle are not the cutting marks.**

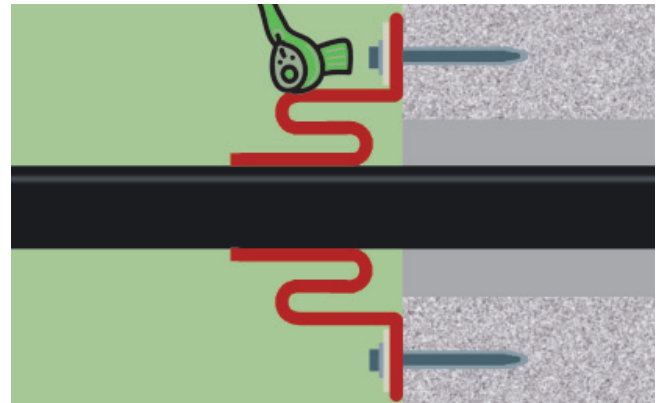

5. Push the side of the Compenseal® with flange bore holes first over the carrier pipe, collar facing the wall. After that interlock Compenseal® with pressure plate and **spread emergent sealing compound**.

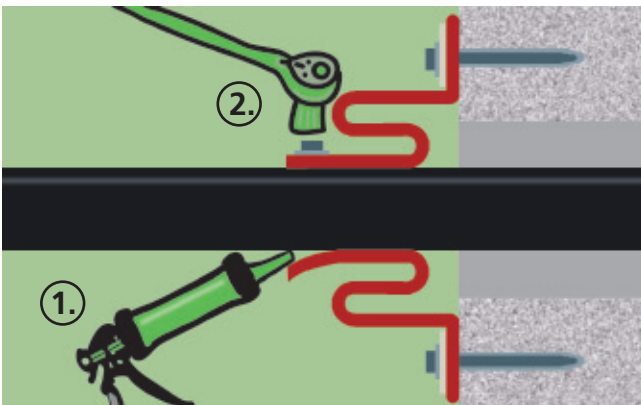

6. Adjust **opening** of the collar to carrier pipe so that a wave shaped expansion zone occurs. **Inject sealing compound** circularly into the collar opening (1) and **fasten bolt strap tightly with 10 Nm** (2).

**Advice:**

- The sealing surface of the wall/ceiling has to be flat and score-free.
- You have to consider that carrier pipe, the wall/ceiling and Compenseal® are dry during the application as well as being free of any fat or dust.
- When laid into the ground the Compenseal® must be covered before backfilling with an **expansion cushion** to ensure that the seal can move in all directions.
- For a carrier pipe size of 315 mm and bigger, a tightening bolt steel strap will be delivered.
- The pipe must be supported in front of and behind the wall to avoid any sagging or bending.
- The bolt strap needs to be retightened with **10 Nm after one hour**.

Subject to technical changes

## Sealing Sleeve - Type KMR 4 pipes



**Pipe movements and subsidence** are the big challenges for a **pipeline wall penetration seal**, especially at **pre-insulated high-temperature pipelines**.

The sealing sleeve type KMR 4 pipes fulfills the high technical requirements to seal wall penetrations securely and permanently, gas- and watertight, especially in larger dimensions.

To deploy this sealing sleeve, it is necessary to have a casing pipe on which a sleeve can be mounted. The sealing system consists of a **sealing sleeve** made of **synthetic elastomer** with a thickness of about 5 mm. A one-component **special-sealing adhesive** has to be injected under the sleeve on both sides.

Two high-quality stainless steel straps press the sleeve on and hold the sealing adhesive in position under stress.

A pressure tightness of up to 1.0 bar can be reached up to an annular space of 75 mm. For larger annular spaces please consult us at 4 pipes.

Place a **compensation cushion** in front of the sleeve before the trench will be backfilled. So a stretching zone is created in case of any expansion.

Sealing sleeve type KMR is available up to a size of 2000 mm carrier pipe diameter. The sealing sleeves are manufactured **individually** and have to be ordered with exact specification of pipe diameters and the expected expansion.

The maximum permanent operating temperature for these sealing sleeves is 55°C. For special requirements, please contact us at 4 pipes.

**The sealing sleeve comes in a set ready to mount with sufficient fastening straps and sealing adhesive in a 310 ml cartridge.**

For retrofit applications, we can find a suitable installation partner for on-site welding with special equipment. In such case, the cost will depend on the required effort.

**Delivery time on request.  
Product will be custom made.**



The pipe must be supported in front of and behind the wall to avoid any sagging or bending.

You can find the technical datasheet for KMR type under ASTM seals on page 28.

The 4 pipes warranty only applies to faulty material. Checking the suitability of the product for the individual application is solely the responsibility of the user.

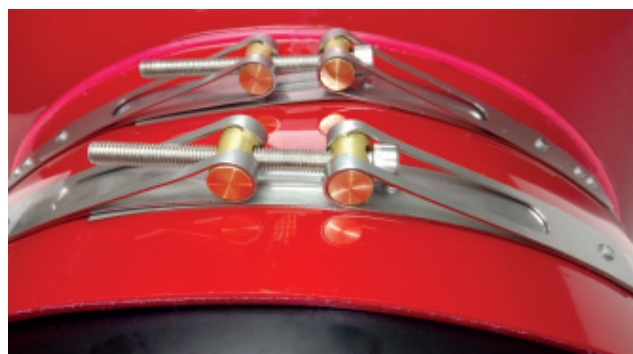

**Tightened 4 pipes-clamping straps with TOX connection technology.**

**No welding, so corrosion protection is optimised.**

**(Used for pipe sizes  $\geq$  DN 300)**

**Torque value for bolt strap 10 Nm**

## Sealing Sleeve - Type KMR 4 pipes

### Application



1. Slide sealing sleeve over the pipe and casing

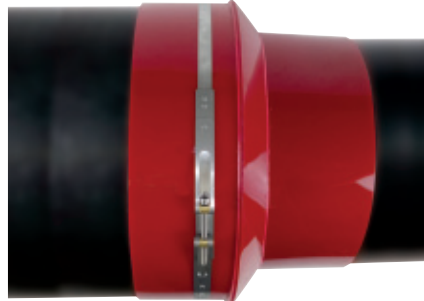

2. Fit the supplied steel strap with max. 10 Nm at the front end of the sleeve on the casing pipe

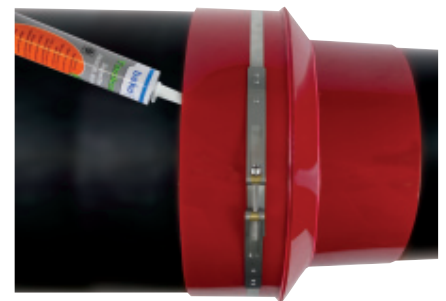

3. Fill the sealant all around under the sleeve



4. Fix second strap with **10 Nm** (smoothen escaping sealant).  
**Repeat step 2 to step 4 on the carrier pipe**



5. Fully assembled sealing sleeve type KMR

6. The bolt strap needs to be retightened with **10 Nm after one hour**

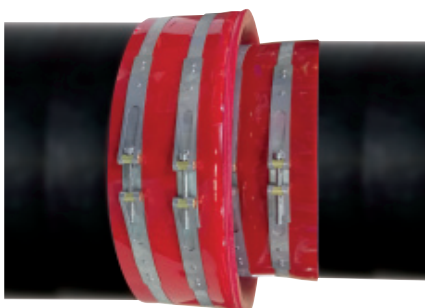

Expansion direction S-shape mounting



Expansion direction stretched mounting



**Before backfilling protect sealing sleeves with expansion-pads**

Split-sleeve version is possible on request.  
The installation can be carried out by DVS trained personnel.





Pipeline Accessories

Wall Collar  
4 pipes



# Wall Collar 4 pipes

## A secure hydrostatic wall penetration seal



### Product information

Wall collars serve as a water barrier for pipelines within the wall or baseplate, especially for wall penetrations where carrier pipes or wall sleeves are directly cast into the concrete. Pressure tight up to 5.0 bar.

The required depth of concrete coverage over the wall collar is to be considered depending on the concrete quality. We recommend a coverage of min. 40 mm for waterproof concrete.

### Usage

#### Hydrostatic sealing of pipelines at baseplate and wall penetrations

- for penetration of various pipe types (copper, steel, cast iron, plastic, fibre cement, concrete, stoneware) through foundations, ceilings, walls and floors
- manhole entering
- swimming pools
- underground tanks

Wall collars are used when the retrofit application of a wall sleeve or core hole is not possible and no adjustable seal makes sense.

### Advantages

- Fast mounting
- Secure water stop up to 5 bar
- Usable for various pipe materials
- Usable for different constructions
- Radon tight

Rubber features	
Service temperature	75 °C max.
Minimum temperature	- 40 °C
Elongation at break	500%
Hardness	45 ±5 Shore A
Tensile strength	9.5 N/mm <sup>2</sup>

### Application instructions

1. Clean pipe surface which has to be set in concrete
2. Put wall collar on the carrier pipe
3. Push wall collar up to the middle of the wall
4. Fix steel straps on both sides around the wall collar

OD 8 mm up to incl. 630 Ø

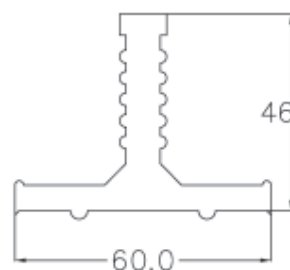

> OD 630 Ø

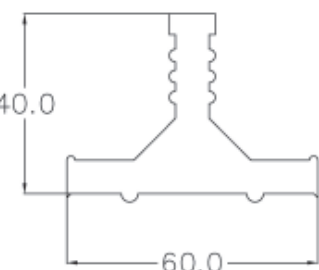

## Application manual Wall Collar 4 pipes

Wall collars serve as a water barrier for pipelines within the wall. Especially at wall penetrations where medium pipes or wall-sleeves are directly cast into the concrete.



Clean pipe surface which has to be set in concrete.



Put wall collar on the medium pipe and center the position of wall sleeve ore core hole.



Fasten steel straps on both sides around the wall collar.



The 4 pipes wall collar is now ready for casting in core hole or wall sleeve.



## Wall Collar 4 pipes

OD Pipe in mm	Range		packaging unit	Art.-No.
	from pipe-OD	to pipe-OD		
20 / 25	18	25	100	12838
32	29	32	100	12800
40	38	42	100	12801
50	48	53	75	12802
63	60	64	70	12803
75	71	80	50	12804
90	84	92	40	12805
100	95	105	30	12839
110	108	116	30	12806
125	120	130	25	12807
140	135	148	25	12808
160	154	166	15	12809
170	166	171	15	12850
180	175	190	15	12810
200	195	210	10	12811
225	215	230	10	12812

OD Pipe in mm	Range		packaging unit	Art.-No.
	from pipe-OD	to pipe-OD		
250	245	260	10	12813
280	275	290	10	12814
315	310	327	10	12815
355	350	365	-	12816
400	395	410	-	12817
450	440	460	-	12818
500	495	515	-	12819
560	555	580	-	12820
630	625	650	-	12821
710	705	735	-	12822
800	795	830	-	12823
900	895	930	-	12824
1000	995	1030	-	12825
1200	1195	1240	-	12826
1400	1395	1450	-	12827

Other dimensions on request

### Wall collar for lightning protection systems



Flat Steel Strip

Steel Wire

#### Product information

The **lightning protection wall collar** type flat steel strip and type steel wire serve as a water barrier within the grounding.

The 4 pipes warranty only applies to faulty material. Checking the suitability of the product for the individual application is solely the responsibility of the user.

OD in mm	Range		Art.-No.
	from OD	to OD	
8	7	10	12835
12	10	14	12836
30 x 3	30 x 2	30 x 5	12837

## Double Wall Collar XL 4 pipes



### Product information

Double Wall Collars XL 4 pipes serve as a water barrier for pipelines within the baseplate or wall, especially for penetrations where carrier pipes or wall sleeves are directly cast into the concrete.

Wall collars are used when the retrofit application of a wall sleeve or core hole is not possible and no adjustable seal makes sense. The required depth of concrete coverage over the wall collar is to be considered depending on the concrete quality. We recommend a coverage of min. 40 mm for waterproof concrete.

### Application

The dimensions of the Double Wall Collar XL 4 pipes are made for plastic and **flexible corrugated plastic pipes**.

Hydrostatic sealing of pipeline wall and baseplate penetrations especially in concrete.

### Advantages

- **Double sealing** collar
- Fast mounting with **only one steel strap**
- Secure water stop according to the W2-E standard (DIN 18533-1)
- Radon tight
- Usable for various pipe materials
- ideal for corrugated pipe due to broad structural shape and **sturdy rubber base** which does not slip between two corrugations
- Easy mounting due to soft rubber compound
- High quality EPDM rubber
- Stainless steel fastening strap

#### EPDM Rubber features

Service temperature	120 °C max.
Minimum temperature	- 40 °C
Elongation at break	min. 500%
Hardness	45 ± 5 Shore A

The 4 pipes warranty only applies to faulty material. Checking the suitability of the product for the individual application is solely the responsibility of the user.

### Application instructions

1. Clean pipe surface which has to be cast in concrete
2. Put wall collar on the carrier pipe
3. Push wall collar up to the middle of the wall / baseplate
4. Fix steel strap around the wall collar
5. Cast into concrete in a professional way

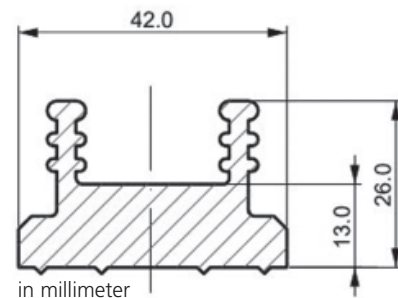

Type	OD wall collar	Art.-No.
Wall collar XL EPDM for OD 25 mm	77 mm	12770
Wall collar XL EPDM for OD 32 mm	84 mm	12771
Wall collar XL EPDM for OD 40 mm	92 mm	12772
Wall collar XL EPDM for OD 50 mm	102 mm	12773
Wall collar XL EPDM for OD 63 mm	115 mm	12774
Wall collar XL EPDM for OD 75 mm	127 mm	12775
Wall collar XL EPDM for OD 90 mm	142 mm	12776
Wall collar XL EPDM for OD 100 mm	152 mm	12777
Wall collar XL EPDM for OD 110 mm	162 mm	12778
Wall collar XL EPDM for OD 125 mm	177 mm	12779
Wall collar XL EPDM for OD 140 mm	192 mm	12781
Wall collar XL EPDM for OD 150 mm	202 mm	12782
Wall collar XL EPDM for OD 160 mm	212 mm	12783
Wall collar XL EPDM for OD 175 mm	227 mm	12784
Wall collar XL EPDM for OD 200 mm	252 mm	12785
Wall collar XL EPDM for OD 225 mm	277 mm	12786
Wall collar XL EPDM for OD 250 mm	302 mm	12787
Wall collar XL EPDM for OD 315 mm	367 mm	12788

5% expandable, Special dimensions on request



Pipeline Accessories

Labyrinth  
Wall Penetration Seals  
4 pipes





# Labyrinth Wall Penetration Seal 4 pipes

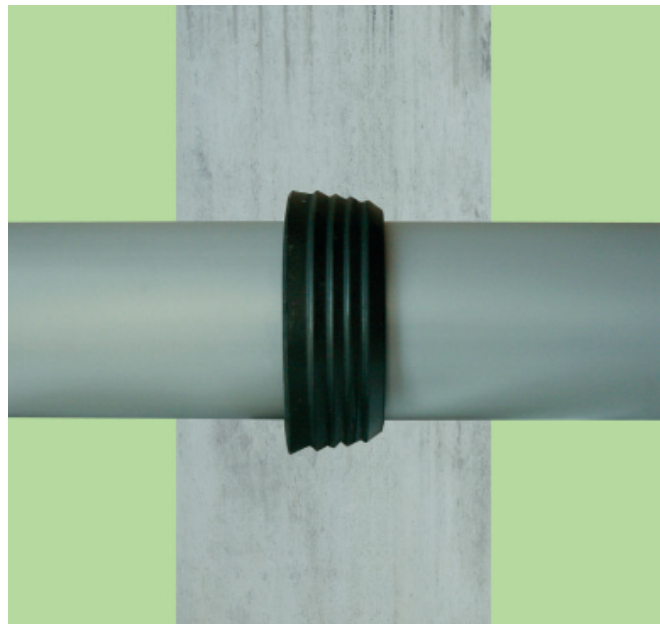
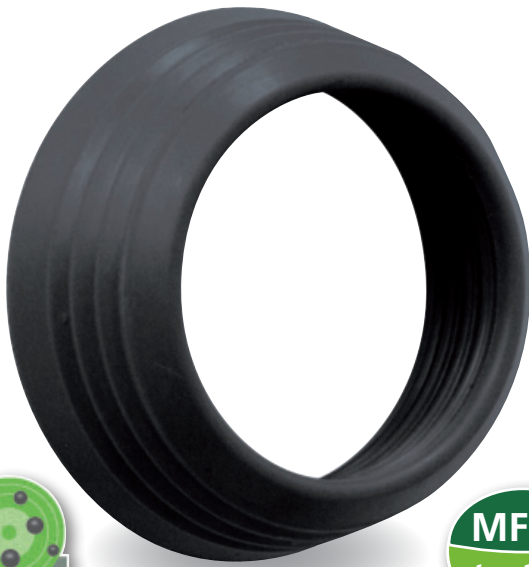

### Product information

Labyrinth seals are directly cast into the wall at building wall penetrations, especially on preinsulated pipelines for district heating as a water stop that is tight against low external water pressure. The high-quality rubber ensures an extremely secure seal. Our Pressio wall penetration seal is suitable as a water stop that is tight against high external water pressure.

### Application

Labyrinth seals are mainly applied on preinsulated pipelines (PE-jacket or flexible district heating pipelines).

- Pressure tight up to 0.5 bar water pressure

### Advantages

- Fast mounting because no tensioning steel straps are necessary
- High-quality rubber ensures an extremely secure seal (up to pipe size 200 mm moulded in one piece)

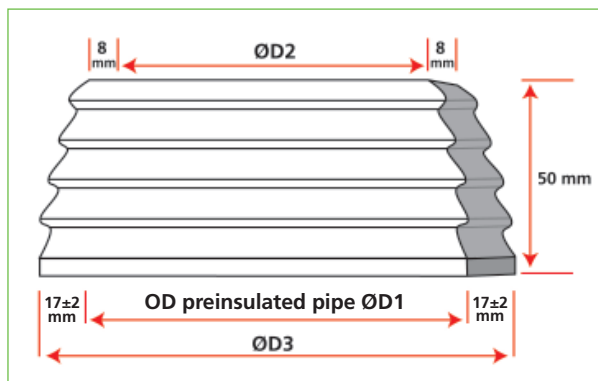

$\text{ØD3 installed} = \text{D1} + 34 \pm 4 \text{ mm}$

The 4 pipes warranty only applies to faulty material. Checking the suitability of the product for the individual application is solely the responsibility of the user.

Available sizes OD 65 mm up to OD 1400 mm.

### Application manual

1. Push Labyrinth seal over the cleaned casing pipe  
Stretchable to tolerances acc. to EN253
2. Cast Labyrinth seal directly in the middle of the wall

OD pipe in mm	Art.-No. Labyrinth Seal
65	12900
75	12901
90	12902
110	12903
125	12904
140	12905
143	12906
160	12907
180	12908
200	12909
225	12910
250	12911
280	12912
315	12913
355	12914
400	12915
450	12916
500	12917
560	12918
630	12919
670	12920
710	12921
800	12922
900	12923
1000	12924



Pipeline Accessories

## Wall and Baseplate Pipe Penetration 4 pipes



# Wall and Baseplate Pipe Penetration KG/KG2000 4 pipes

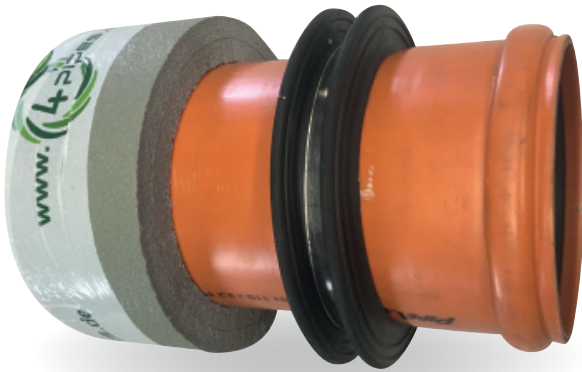

resistant to  
5 bar



## Wall and baseplate pipe penetration KG / KG2000

Wall and baseplate pipe penetrations 4 pipes are solutions to provide a tight seal against high external water pressure from outside a structure, in the case that a pipe is directly cast into watertight concrete.

The preassembled set contains the piece of pipe, a tight double wall collar and an end cap for uncomplicated application. The required concrete cover of the wall collar is to be considered depending on the concrete quality. We recommend a coverage of min. 40 mm for waterproof concrete.

### Application

- In the formwork for casting in concrete
- Wall penetrations in structures
- Manhole sewer penetrations
- In the baseplate of a building

### Advantages

- Integrated double wall collar saves application time
- Double wall collar 4 pipes is approved and certified against 5 bar high external water/gas pressure
- Length adjustable on site
- Attached foam spacer allows later connection to the spigot
- Supplied incl. blind plugs for the bell side

### Product range

- Pipe PVC KG and PP KG2000 (other on request)
- Dimensions OD 110, 125, 160, 200 mm

### Wall penetrations:

- For wall thicknesses 240 mm to 500 mm
- Other pipe qualities (e.g. HT-pipe) dimensions and length on request

### Baseplate penetrations:

- Standard length 500 mm
- Other pipe qualities (e.g. HT-pipe) dimensions and length on request

### Application

1. Cut penetrating pipe to length if necessary
2. Insert into the cast. The wall collar should be in the middle of the concrete formwork, fully covered
3. The sealing ring in the bell must be cleaned and lubricated properly before inserting the next pipes

## Baseplate pipe penetration 4 pipes

	Pipe OD mm	Art.-No.
<b>KG2000 pipe (PP green)</b>	110	27728
	125	27729
	160	27730
	200	27731
<b>KG pipe (PVC orange)</b>	110	27732
	125	27733
	160	27734
	200	27735

## Wall penetration 4 pipes

	Pipe OD mm	possible length	Art.-No.
<b>KG2000 pipe (PP green)</b>	110	200 – 560 mm	27704
	125	200 – 560 mm	27705
	160	300 – 580 mm	27706
	200	300 – 600 mm	27707
<b>KG pipe (PVC orange)</b>	110	200 – 560 mm	27708
	125	200 – 560 mm	27709
	160	300 – 580 mm	27710
	200	300 – 600 mm	27711

Supplied incl. end cap and preassembled double wall-collar, tight against high external water pressure.

### On request:



Wall pipe penetration with bell on both side

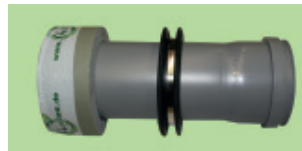

Wall pipe penetration made of HT-pp-pipes grey



Baseplate pipe penetration incl. glue-on flange





Pipeline Accessories

## Wall Sleeves and Coatings 4 pipes

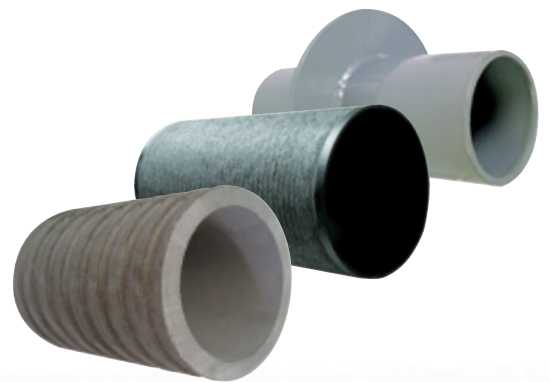

## Wall Sleeves Fibre Cement 4 pipes

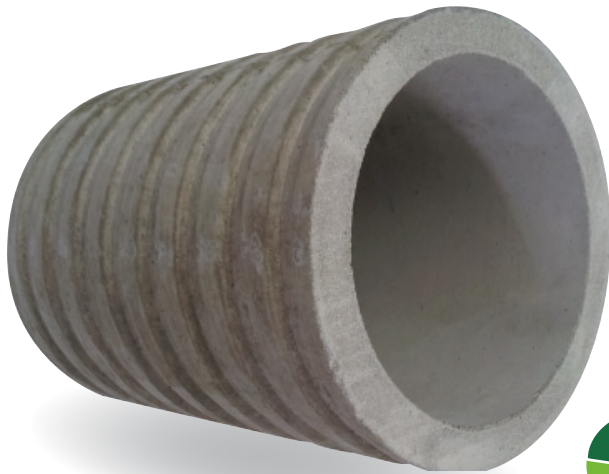

**MFPA  
tested**

### Wall sleeves, fiber cement, plastic, steel

The wall sleeves serve in combination with our Pressio and Pressio-Elements Seals to penetrate carrier pipes of any material (copper, steel, cast iron or plastic) through walls, ceilings and floors. They form a perfect wall opening for the seals, so an optimum sealing is guaranteed.

### Wall sleeve of asbestos-free fibre cement

- Colour light grey
- Grooves outside all around
- Smooth inside walls

The sleeve which consists of concrete and glass fibre is water pressure tight, non-flammable, corrosion resistant and electrically insulating. They are extremely firm, which means they can be coated and perfectly bonded to concrete so that it is possible to cast into concrete or into a wall. For the use in concrete tanks or containers the wall sleeve can be coated. Watertight fitting with mortar in a wall breakthrough is also possible.

### Sizes:

DN 80 up to DN 800, length of 200 mm up to 1500 mm\*\*\*

Inside diameter in mm*												
80	100	125	150	200	250	300	350	400	500	600	700	800
Outside diameter in mm**												
135	144	166	195	245	304	352	400	458	569	671	769	879

Please find all standard dimensions and length in our latest pricelist.

\*\*Outside diameter are subject to tolerances of  $\pm 8$  mm

\*\*\*DN 500 up to DN 800 max. manufacturing length

L=960  $\pm 20$  mm tolerance

Please consider the following advice if adjustments at the fibre cement wall sleeve have to be done on site:

1. **Always wear a mask when cutting/working on the sleeve**
2. **Cut/work on fibre cement only wet** and only with hand-operated or slow moving machines with dust trashrack

Minimum 50 mm projecting wall sleeves can be integrated into an existing bitumen sealant in a professional way.



### PE end cap

for wall sleeves 4 pipes with a ID 80 mm up to 300 mm

Ø ID Wall sleeve in mm*	Art.-No.
80	13020
100	13021
125	13022
150	13023
200	13024
250	13025
300	13026

\*Tolerances ID  $\pm 2$  mm

The 4 pipes warranty only applies to faulty material. Checking the suitability of the product for the individual application is solely the responsibility of the user.

## Split Wall Sleeve Fibre Cement 4 pipes

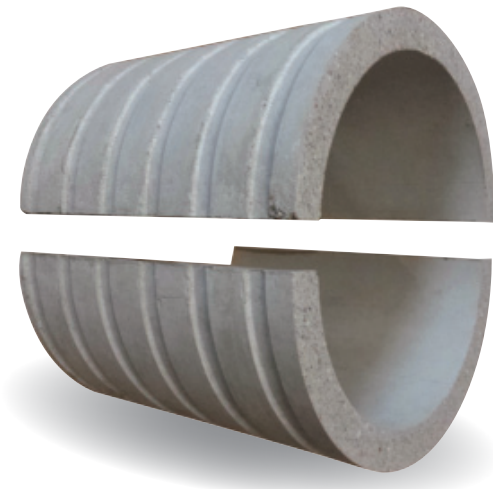

### Product Information

#### Split wall sleeve fibre cement

Split fibre cement wall sleeves 4 pipes are available in dimensions from 100 to 800 mm for retrofit purposes.

The two half shells are bonded together on site with a special Epoxy adhesive.

**The wall sleeve is supplied in two exact half shells, which provide one round sleeve without any gap or ovality.**

To bond the surfaces, these must be clean, dry and free from oil or grease.

The epoxy adhesive is mixed well in the package and applied to the cement edges. Afterwards the two half shells are joined and pressed together with fastening straps or binding wire.

Special spacers between the surfaces are not necessary.

24 hours after joining, the wall sleeve can be cast into concrete.

#### Wall sleeve of asbestos-free fibre cement

- Colour light grey
- Grooves outside all around
- Smooth inside walls

The sleeve, which consists of concrete and glass fibre, is water pressure tight, non-flammable, corrosion resistant and electrical insulating. They feature a high firmness, able to be coated and perfect bond to concrete so that it is possible to cast in concrete or into a wall. For the use in concrete tanks or containers the wall sleeve can be coated. Also the water tight fitting with mortar in a wall breakthrough is possible.

» Availability only on request «

### Application instructions for split fibre cement wall sleeves

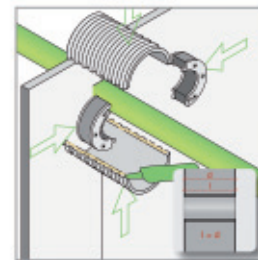

1. Mix epoxy kit and apply epoxy out of the bag on the edge of the half-shells and join the two halves. Smoothen excessive epoxy with a cloth inside and outside. Centre the half-shells with the wall penetration seal if available.

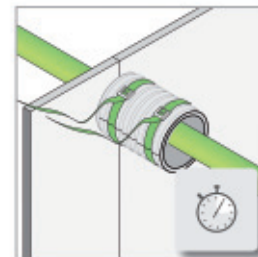

2. Fix the half-shells with a fastening strap or steel wire. Make sure the curing time is not less than three hours before filling in the concrete.

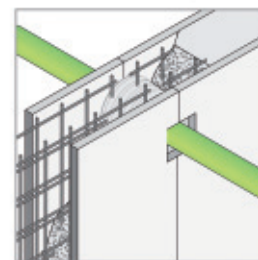

3. Integrate wall sleeve into the casting.

Please consider the following advice if adjustments at the fibre cement wall sleeve have to be done on site:

1. **Always wear a mask when cutting/working on the sleeve**
2. **Cut/work on fiber cement only when wet** and only with hand-operated or slow moving machines with dust trashrack



# PVC Wall Sleeves 4 pipes

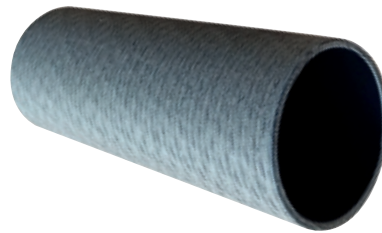

PVC wall sleeve

ID in mm*	OD in mm	Length in mm**	Art.-No.
50	54	400	13000
60	64	400	13001
70	75	400	13002
70	75	2000	13058
80	85	400	13003
80	85	2000	13019
90	95	400	13004
100	106	400	13005
100	110	400	13006
100	110	3000	13018
125	131	400	13007
125	131	3000	13066
150	158	400	13008
150	158	3000	13060
200	210	400	13009
200	210	1500	13061
250	280	400	13010
250	280	1000	13062
300	315	400	13013
300	315	1000	13064

\*\*other lengths on request

## PVC wall sleeves

- Special roughening for optimum bond to the wall
- Suitable to wall in and cast to concrete
- Delivery in standard length of 400 mm (adjustment to wall thickness cut to length possible with a saw)
- Also available with sleeve and seal as well as with increased wall thickness
- PE casting cap as accessory for PVC wall sleeves with ID 60 mm up to 300 mm
- Welded adhesive flange for connecting thick coatings according to DIN 18533 available
- Material PVC-U

**Sizes:** DN 50 up to DN 300 in 400 mm length (on request up to 2 m)

## Technical data

For sizes and dimension please have a look at our price list or ask us at 4 pipes.



**PE endcap:**  
for PVC-wall sleeve with a ID of 80 mm up to 300 mm

Ø ID Wall sleeve in mm	Art.-No.
80	13020
100	13021
125	13022
150	13023
200	13024
250	13025
300	13026

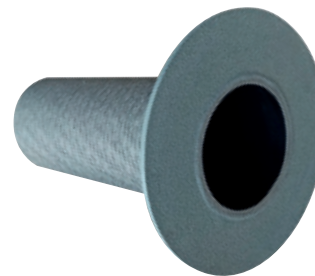

PVC wall sleeve with bonding flange

ID in mm*	OD in mm	OD bonding flange in mm	Length in mm**	Art.-No.
80	85	185	400	13873
100	110	210	400	13876
125	131	231	400	13877
150	160	260	400	13878
200	210	310	400	13879
250	280	380	400	13880
300	315	415	400	13881

\*\*other length on request

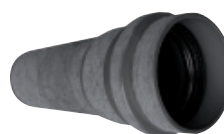

Wall sleeve with formed bell and seal

ID in mm*	OD Bell in mm	Length in mm	Art.-No.
100	110	500	13011

\*Tolerances ID ±2 mm

# PVC Wall Sleeves 4 pipes

## Application instructions

### General advice

- choose wall sleeve according to the exact diameter of the pipe and the corresponding Pressio® or Pressio®-Elements seal
- insert the seal after setting the sleeve in concrete

### On-site adjustments

- Always wear a dust mask when cutting / processing the sleeves
- Cut PVC sleeves only manually or with slowly turning tools with dust collector
- Do not inhale the dust

### Application in the shuttering

1. Fix wall sleeve in the casting with PE casting caps.
2. Application in base floors, ceilings or walls.
3. Compress concrete well around the wall sleeve.



## Installation of the PVC wall sleeve in the waterproofing of buildings according to DIN 18533:

### Preparation of the surface (PVC wall sleeve)

The surface of the PVC wall sleeve must be frost-free, free of release agents, free of mortar residues and free of loose contaminants. After the surface preparation the waterproofing layer is applied in accordance with the manufacturer's instructions.

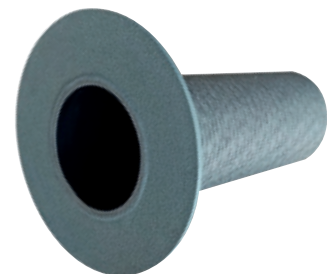
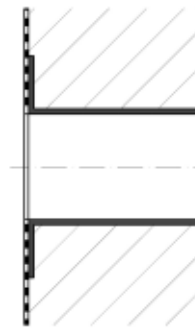
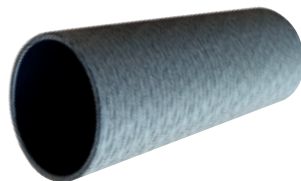
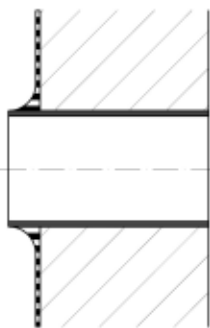

### Water impact class W1-E - low external water pressure

Installation of a wall sleeve without bonding flange:

The seal (e.g. polymer-modified bituminous thick layer coating PMBC) is attached to the wall sleeve like fillet. For this purpose, the wall sleeve must be installed with the adequate protruding length on the outside.

### Water impact class W2.1-E - high external water pressure up to max. 3 m

Installation of a wall sleeve with bonding flange:

The protective film is removed before the sealing layer is applied. The seal is attached to the wall sleeve including reinforcement layer according to DIN 18533.

## PVC Shaft Linings 4 pipes



### Product information

**PVC shaft linings with integrated seal** are designed to connect pipes to structures when water pressure is low:

- PVC sewer pipes like KG etc.
- Cable casing pipes
- All plastic pipe acc. to DIN EN 1401-1 at shaft structures

PVC shaft linings are available for pipe OD:

- 110 mm Ø
- 125 mm Ø
- 160 mm Ø

**For a perfect bond to the concrete, the PVC shaft lining 4 pipes have a special roughened outside surface.**

### Advantages

- Inexpensive wall penetration solution
- Pipe adjustment possible
- Quick application
- Can be cut to length easily if necessary to adjust to wall thickness
- **For connecting, the carrier pipe can be pushed through completely**



### Sizes

Shaft linings PVC for pipe OD in mm	Length in mm	Art.-No.
110	110	13030
110	250	13032
110	300	13035
125	110	13038
125	250	13033
125	300	13036
160	110	13031
160	250	13034
160	300	13037

Other sizes on request

### General comments

- **The sizing of the shaft linings is acc. to the OD of the carrier pipe**
- Insert carrier pipe after casting in the shaft lining
- Compress concrete well around the shaft linings

If on-site adjustments must be made, please note the following instructions:

- Wear a dust mask when the PVC has to be cut
- Cut PVC with slow-moving tools and soak off the dust during and after cutting



# Steel Wall Sleeves 4 pipes

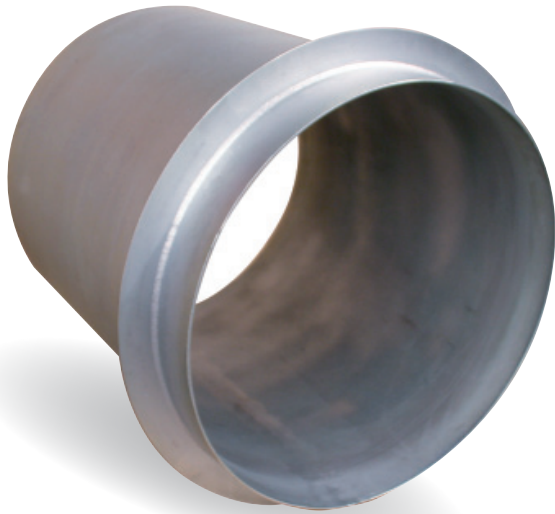

### Steel wall sleeve

Steel wall sleeves form a perfect wall opening for the installation of an annular seal. Wall sleeves made of steel are manufactured individually and order-related.

- Wall sleeve of welded or seamless steel pipes
- Corrosion protection (black/galvanized/powder coated or of stainless steel) individually to customer specifications
- Delivery is made with standardized welded-on anchor flange (ring-shaped plate serves as wall anchor and as a waterstop at the OD of the sleeve). Alternative position of anchor flange accord. to customers specification possible

### Technical data

For sizes and dimensions, please have a look at our price list or ask us at 4 pipes.



### General advice

- Choose wall sleeve according to the exact diameter of the pipe and the respective Pressio® or Pressio®-Elements.
- Insert the seal after casting the sleeve into the concrete

### Application in the shuttering

1. Fix wall sleeve in the casting with PE endcaps
2. Application in base floors, ceilings or walls
3. Compress concrete well in area of the wall sleeve

### Standard dimensions

DN	Dimension in mm (Ø x s x l)	ID Sleeve
50	60.3 x 2.9 x 300	54.5
65	76.1 x 3.6 x 300	68.9
80	88.9 x 4.0 x 300	80.9
100	114.3 x 4.0 x 300	106.3
125	139.7 x 5.0 x 300	129.7
150	168.3 x 5.0 x 300	158.3
200	219.1 x 5.0 x 300	209.1
250	273.0 x 5.0 x 300	263.0
300	323.9 x 6.0 x 300	311.9
350	355.6 x 6.0 x 300	343.6
400	406.4 x 6.0 x 300	394.4
500	508.0 x 6.0 x 300	496.0
600	610.0 x 8.0 x 300	598.0
700	711.0 x 8.0 x 300	695.0
800	813.0 x 8.0 x 300	797.0

Ask 4 pipes about your individual specifications.

## Epoxy Coating Resin 4 pipes



### Product information

Epoxy resin 4 pipes is a high quality coating for surfaces, especially stonework, concrete or steel. **Core drilled holes at wall penetrations are coated to avoid entry of water into the wall.**

Epoxy resin 4 pipes comes in a kit which is suitable for sites, including safety gloves and an application brush. The two components are supplied in the right mixing ratio to be easily mixed together on site.

**After mixing in a pot, approx. 15 minutes remain** for a secure hand-ling of the total package. The surface to be coated has to be clean, dry (with concrete residual moisture <4%) and fat-free.

If the coating is used as a high-quality corrosion protection system on steel, the surface might need preparation with a degree of purity of SA 2 1/2 (sand blasting). For a correct hardening the surrounding temperature should be above 5°C and the relative humidity below 60%.

The product is applied with a brush. Up to 3 layers can be applied on top of each other. Depending on the layer thickness and surface roughness, a container of 1.0 kg is sufficient for about 3 square metres ±. Curing time is 12 to 24 hours depending on temperature.

Epoxy resin 4 pipes is highly suitable and approved for applications with drinking water.

This material complies with the **UBA-BWGL and DVGW W270**. Before the first contact with drinking water the coating has to be flushed with hot water.

Electrical strength max. 9 KV / mm,  
Do pore test with max. 5 kV.

For your safety when applying it is necessary that:

- There is enough **fresh air**
- You wear **safety clothing** plus
- Safety goggles and gloves
- Safety data sheet on request

**Epoxy-Kit incl. brush and gloves**  
**4 pipes Art.-No. 13099 - 1.0 kg unit**

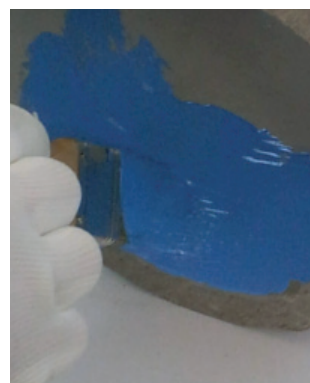

The 4 pipes warranty only applies to faulty material. Checking the suitability of the product for the individual application is solely the responsibility of the user.



# 1K Beto-coat 4 pipes



Art.-No. 13096  
0.75 ml can

### Product information

1K Beto-coat 4 pipes is a high quality coating for surfaces, especially concrete, stonework, steel and other materials. Core drilled holes at wall penetrations are coated to avoid entry of water into the wall.

1K Beto-coat 4 pipes comes in a kit which is **suitable for sites**, including safety gloves and an application brush. It consists of an alkyd-epoxy resin mixture and binds exceptionally strongly to the substrate. Good filling and covering capacity, rust-blocking, anti-corrosive, ventilating, productive.

As a one-component system, the can is **resealable after use** and the remaining container can be **used for the next application**.

### Processing

1K Beto-coat 4 pipes can be applied with a brush, roller or by spraying. The surface must be clean, free of grease and dust. Use on a slightly damp surface is possible.

Before applying, stir the contents of the can well until the resin mixture appears homogeneous. After that, the coating is applied on the surface. At least two layers of 1K Beto-coat are required to achieve the full coating quality.

### Technical data

Drying time	dust-dry after 30-45 minutes, able to paint over after 2-3 hours, nitro tight after 12 hours
Coverage	approx. 5 m <sup>2</sup> per litre
Thinner	use universal thinner to spray and clean the equipment

### Safety instructions

Use only in well-ventilated rooms. Do not inhale spray. Avoid contact with eyes. Keep out of the reach of children. Do not pour into drains. Flammable. Safety data sheet on request.

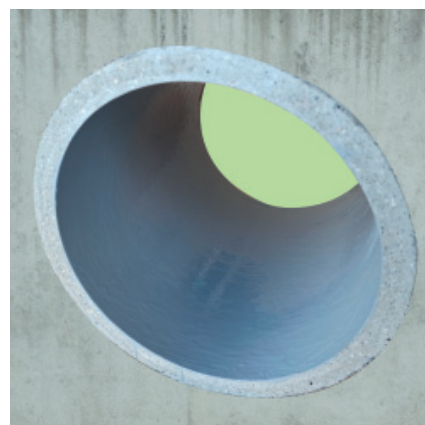





Pipeline Accessories

Rubber Steel Gaskets  
4 pipes



## Flange Gaskets - Type RSG 4 pipes



DVGW Registration  
number: NG-5113DM0218

### Product Information

**RSG 4 pipes Rubber-Steel-Flange-Gaskets** are manufactured of friction-locked vulcanised elastomer with an inner steel ring. The elastomer body provides secure sealing of the flange connection. The special shape with the elliptic ring on the inside provides an in-built seal with additional, functional sealing potential. This special shape works like an additional "O-ring". The inner steel ring provides a high level of physical stability and long-term functionality. Clear identification marking in different colours prevents any mismatching or mix-ups.

### Material qualities, approvals and technical data

#### RSG-TW for drinking water and sewage water networks: EPDM

Operating temperature: -25°C to +120°  
Hardness degree: 70+/-5 Shore A  
Approvals: **DVGW W270, Elastomer guide line of UBA/KTW, WRAS and ACS,** DVGW certificate of conformity hygiene  
Specifications: DIN-EN 681-1, Type WA/WC/70

#### RSG-G for Gas Systems: NBR

Operating temperature: -25°C to 90°C  
Hardness degree: 80+/-5 Shore A  
Approval: **DVGW-EN 682** (Installation for transport and distribution of gases or liquid hydrocarbons, hydrogen resistant)  
Specifications: DIN-EN 682, Type GBL/80;  
**DIN-EN 30690-1/EN 13555/VDI 2200 Possible field of application up to incl. PN40 (DP40) - tested, certified**

#### RSG-FKM for the chemical Industry

Operating temperature: -25°C bis 200°C  
Hardness degree: 70 ± 5 Shore A  
Out of all the elastomer qualities, FKM has the best resistance to heat, chemicals and solvents.

Other materials on request.

### Application

Rubber-steel-flange gaskets are intended for:

- drinking water pipelines and systems
- sewage water pipelines and systems
- gas pipeline systems
- all iron, stainless steel, cast iron and plastic flange connections



The elastomers offers a wide range of resistancy.

**EPDM** provides excellent resistance to several substances, including different chemicals, industrial water, aqueous salt solutions and is **DVGW approved for drinking water application.**

#### Very good ozone and UV resistance!

**NBR** provides excellent resistance to several substances, including different mineral oils, fuels, greases, other hydrocarbons and **100% H<sub>2</sub> hydrogen.** **DVGW approved for gas application.**

**FKM** is very resistant to alkalis, acids and high temperatures.

Chemical resistance table available: [www.4pipes.de](http://www.4pipes.de)

### Advantages

- printing and colour markings according to standards
- self-centring (inner-bolt-circle layout)
- easy assembling
- high tightening value at low bolt forces due to special shape (elliptic ring)
- best performance for secure tightening in plastic flanges
- high physical stability in assembling and operating process
- high operating safety
- no retorquing required
- no leakage
- cost efficient

### RSG flange gaskets - Types

<b>RSG-TW</b> <b>RSG-FKM</b> <b>RSG-G</b>	Manufactured acc. to DIN EN 1514-1 (formerly DIN 2690) type IBC for flanges acc. to DIN EN 1092-1 and -2
<b>RSG-TW-K</b> <b>RSG-G-K</b> <b>RSG-FKM-K</b>	Manufactured for <b>PE/PP/PVC/PVDF pressure pipe</b> Flanges with <b>plastic welding necks, lap-joint flanges with welding rod or flanged bush</b> similar to DIN 16962-4 (PP)/DIN 16963-4 (PE)/DIN EN 1092-1 (DIN 2501 PN 10/16) Type IBC
<b>RSG- ANSI</b>	Manufactured for ANSI/ASME B16.5 type IBC flanges

**For all available dimensions and pressure ratings, please see our price list or feel free to ask for what is required.**

The 4 pipes warranty only applies to faulty material. Checking the suitability of the product for the individual application is solely the responsibility of the user. 4 pipes does not grant any warranty for pre-installed or reused flange gaskets.

## Flange Gaskets - Type RSG-TW-V 4 pipes



### Product Information

**RSG-TW-V rubber steel flange gasket** is a two-piece construction, made from elastomeric material vulcanized over steel rings.

**With its twist and plug mechanism, the RSG-TW-V can be adjusted to the angle of the sealing surface.**

Elastomeric elements provide secure sealing against fluids on flange connections with **non-parallel flange surfaces**. The two-piece construction of conical elements not only forms the seal, but also compensates for angular misalignment by allowing **adjustment up to 8°**.

Steel rings, vulcanized into the elastomeric elements, ensure mechanical stability and long term functionality.

### Material qualities and technical data

**RSG-TW-V** for water, various other fluids, industrial applications and waste water:

	<b>EPDM</b>
Operating temperature:	-25° C up to +120° C
Hardness:	70 ±5 Shore A
Approvals:	<b>DVGW W270, Elastomer guideline of UBA/КТW, WRAS and ACS, DVGW certificate of conformity hygiene</b>
Specifications:	DIN-EN 681-1, Type WAWC/70

Other material qualities and certificates are available on request.

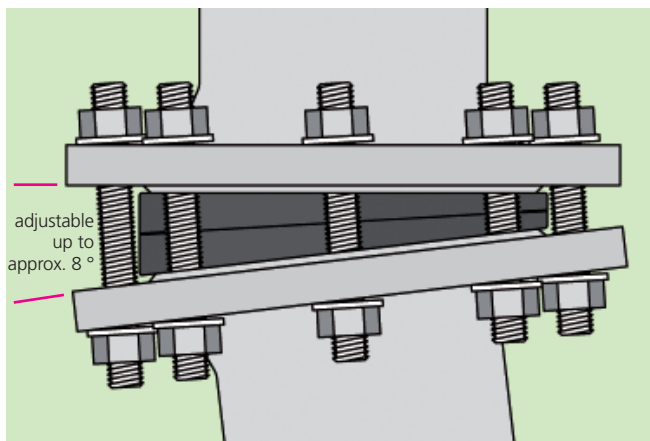

### Application

**RSG-TW-V** flange gaskets are intended for:

- flange connections with sealing surfaces not parallel to each other
- hydrants with misaligned connection tee / duckfoot bend
- for flange gaskets (adaptation to existing flanges)

**Elastomer EPDM** provides excellent resistance to several substances, including different chemicals, industrial water, aqueous salt solutions and is **DVGW approved for drinking water application**. Very good ozone and UV resistance!

Chemical resistance table available: [www.4pipes.de](http://www.4pipes.de)

### Unique advantages

- Easy and cost effective installation due to adjustment of sealing surfaces
- excellent resistance to substances in pipes
- vulcanized steel rings provide long term stability
- high tightening value at low bolt forces
- no retightening of bolts
- excellent operational reliability
- no leakage
- cost effective because follow-up costs are avoided

### Dimensions and pressure rates

RSG-TW-V flange gaskets are manufactured according to DIN-EN 1514-1 (comparable to old DIN 2690), form IBC, self-centering in flanges according to DIN-EN 1092-1, DIN-EN 1092-2.

Please find available dimensions and pressure rates in our price list or contact us.

The 4 pipes warranty only applies to faulty material. Checking the suitability of the product for the individual application is solely the responsibility of the user. 4 pipes does not grant any warranty for preinstalled or reused flange gaskets.



# Flange Gasket - Type RSG and RSG-TW-V 4 pipes



## Installation RSG

- the sealing line of flange surfaces needs to be clean, free of grooves and edges
  - insert the gasket carefully between the flanges
  - lubricate bolts
  - insert bolts into bolt holes
  - tighten bolts evenly (in three steps 30% + 40% + 30%) with a torque wrench according to the tightening torque table specification below
  - tighten bolts in a diagonally opposite sequence as shown in the picture on the right
- For any other installation or operation situation please contact our customer service.

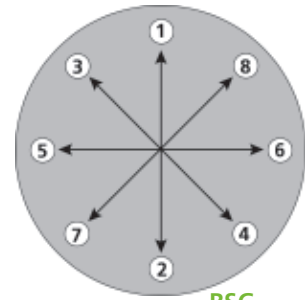

RSG

## Installation RSG-TW-V

- sealing lines of flanges must be **clean and free of grooves and edges**
  - extra long bolts with smaller diameter might be necessary
  - adjust angle of RSG-V according to misalignment of flanges by plugging and twisting sealing elements into each other
  - IBC form ensures self-centering of gasket
  - insert the gasket carefully between the flanges
  - lubricate bolts
  - insert bolts into bolt holes
  - tighten bolts evenly (in three steps 30% / 40% / 30%) **in a clockwise direction (see picture to the right)** with a **torque wrench** according to table below
- For any other installation or operation situation please contact our customer service.

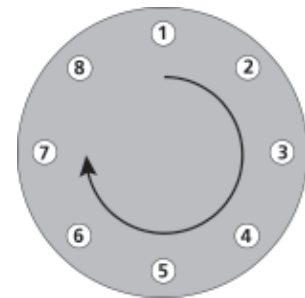

RSG-TW-V

## Important advice

Gaskets should only be installed once. Don't apply any additional sealant, lubricant or glue on the installed gasket. Never install more gaskets on top of the first one. Please adhere to the installation instructions/regulations and requirements for qualified fitters, in accordance with DIN-EN 1591.

Torques values for flange gaskets type RSG and RSG-TW-V					
Values for steel flanges in Newtonmeter (Nm)					
DN	PN 6	PN 10	PN 16	PN 25	PN 40
15	15	30	20	25	25
20	25	30	40	25	40
25	25	30	40	25	40
32	40	100	100	100	100
40	40	100	100	100	100
50	70	100	100	100	100
65	70	100	100	100	100
80	100	100	100	100	100
100	100	100	100	200	200
125	100	100	100	310	310
150	100	200	200	310	310
200	100	200	200	310	450
250	100	200	310	450	720
300	200	200	310	450	720
350	200	200	310	720	980
400	200	290	450	820	1200
450	-	290	-	-	-
500	200	290	550	820	-
600	300	420	750	1200	-
700	300	420	750	1300	-
800	350	610	960	1850	-
900	400	610	960	1850	-
1000	400	800	1300	2600	-
1200	550	1100	1200	-	-
1400	-	1400			
1600	-	1930			
1800	-	1930			
2000	-	1930			

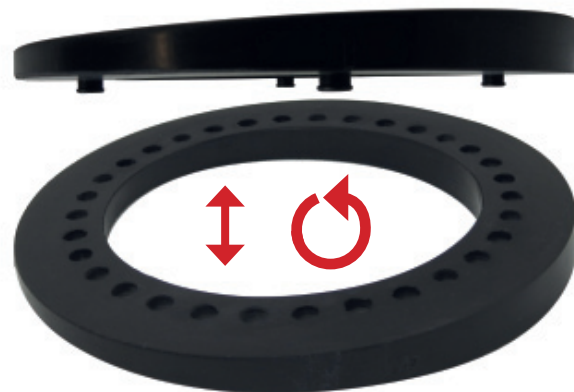

RSG-TW-V (twist and plug tmechanism)

The RSG gasket was tested and calculated by the laboratory company amtec Messtechnischer Service GmbH.

**Calculated for flanges on the basis of EN 1591-1, considering the specific gasket values acc. to DIN EN 13555 and VDI 2200.**

Values based on friction  $\mu = 0.14$  (bolts lubricated). Bolts quality 5.6 or higher. Flange quality: 1.0460 (C22.8)

For PE flanges please note:

The torque value must be adjusted to the grade of the PE flange. All informations on tightening torques can be obtained from the flange manufacturer.

Also note DVS2210-1 B3.

Checking the suitability of the product for the individual application is solely the responsibility of the user. 4 pipes does not grant any warranty for preinstalled or reused flange gaskets.

## Flange Gaskets - Type RFG 4 pipes



### Product information

**Rubber Flexible Gasket RFG 4 pipes** made of elastomer material with fixing eyelets to be fitted in pipeline flanges. Mould-vulcanised elastomer ring with eyelets for easy positioning and fixing on the bolts of pipeline flange connections.

### Material qualities, technical data

#### RFG for water and sewage water: EPDM

Operating temperature: -25°C to +120°C  
 Hardness: 70 ±5 Shore A acc. ISO 48  
 Standard: DIN-EN 681-1 Type WC/70

DN Pipe	suitable for PN	RFG ID mm	RFG OD mm	thickness mm
32	6/10/16	40	71,5	3
40	6/10/16	50	83	3
50	6/10/16	60	97	3
65	6/10/16	75	121	3
80	6/10/16	80	130	3
100	6/10/16	100	154	3
125	6/10/16	125	183	3
150	6/10/16	150	209	3
175	6/10/16	175	223	4
200	6/10/16	200	263	4
250	6/10/16	250	313	4
300	6/10/16	300	364	4
350	6/10/16	350	425	4
400	6/10/16	400	476	4
450	6/10/16	450	545	4
500	6/10/16	500	576	5
600	6/10/16	600	676	5
700	6/10/16	700	790	6
800	6/10/16	800	890	6
900	6/10/16	900	990	6



### Application

RFG rubber flange gaskets are intended for:

- water pipeline systems
- sewage water pipeline systems
- all iron, stainless steel, cast iron and plastic flange connections as well as coated flanges.

The elastomer provides excellent resistance to many substances in pipes. **EPDM** is highly resistant to a variety of different salts, acids, alkalis and aqueous solutions.

#### Very high resistance to UV and ozone!

Substance resistance table available: [www.4pipes.de](http://www.4pipes.de)

### Advantages

- low-cost gasket
- easy installation using fixing eyelets
- low-torque installation

### Dimensions and pressure ratings

RFG flange gaskets are suitable for steel flanges, stainless steel, cast iron (with or without coating) and plastic, with the option of pre-fixing to flange bolts.

Please refer to the available dimensions in our price list and the table on the left.

RFG flange gaskets are suitable for PN6, PN10 and PN16 pressure ratings.

The 4 pipes warranty only applies to faulty material. Checking the suitability of the product for the individual application is solely the responsibility of the user. 4 pipes does not grant any warranty for preinstalled or reused flange gaskets.

## Flange Gaskets Type RFG 4 pipes

### Installation instructions

- the sealing line of the flange surface needs to be clean, free of grooves and free of edges
- the flange surfaces need to be aligned
- insert 2 bolts in bolt holes for eyelets
- insert the gasket carefully between the flanges and fix the eyelets on the bolts
- lubricate bolts
- insert the remaining bolts in the holes
- tighten bolt evenly (in three steps 30%-40%-30%) with a torque wrench according to the tightening torque table spec. below
- tighten bolt in a diagonally opposite sequence as shown in the picture on the right

### Important to know

- only install gaskets once!
- don't install more gaskets on top of the first one!
- only use quality gaskets!
- don't apply any lubricant, sealant or glue to the installed gasket!
- please adhere to the installation instructions/regulations and requirements for qualified fitters, in accordance with DIN-EN 1591!

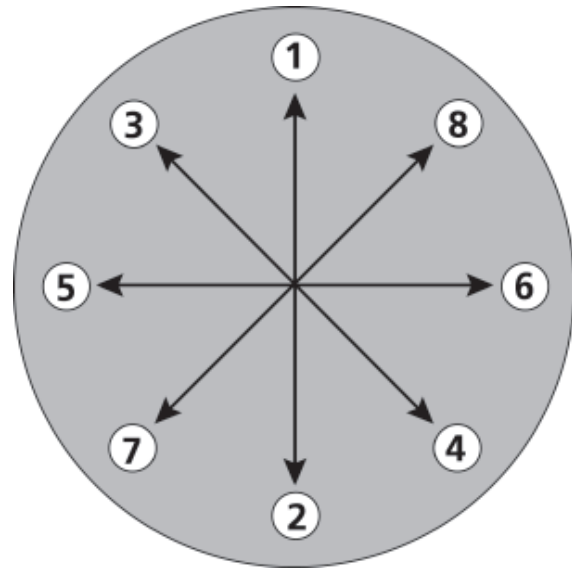

**Torques values for flange gaskets type RFG**  
Values in Newtonmeter (Nm)

DN	RFG
15	15 Nm
20	20 Nm
25	25 Nm
32	40 Nm
40	50 Nm
50	60 Nm
65	50 Nm
80	60 Nm
100	65 Nm
125	70 Nm
150	100 Nm
200	140 Nm
250	120 Nm
300	140 Nm
350	190 Nm
400	280 Nm
500	280 Nm
600	360 Nm
700	400 Nm
800	550 Nm
900	650 Nm

Values based on friction  $\mu = 0.14$  (bolt lubricated).  
Bolt quality 5.6 or higher.

For PE flanges please note:  
The torque value must be adjusted to the grade of the PE flange.  
All informations on tightening torques can be obtained from the flange manufacturer. Also note DVS2210-1B3.

Checking the suitability of the product for the individual application is solely the responsibility of the user. 4 pipes does not grant any warranty for preinstalled or reused flange gaskets.





Pipeline Accessories

Combi-Seal 4 pipes  
Flange Isolation Gaskets,  
Isolation Accessories

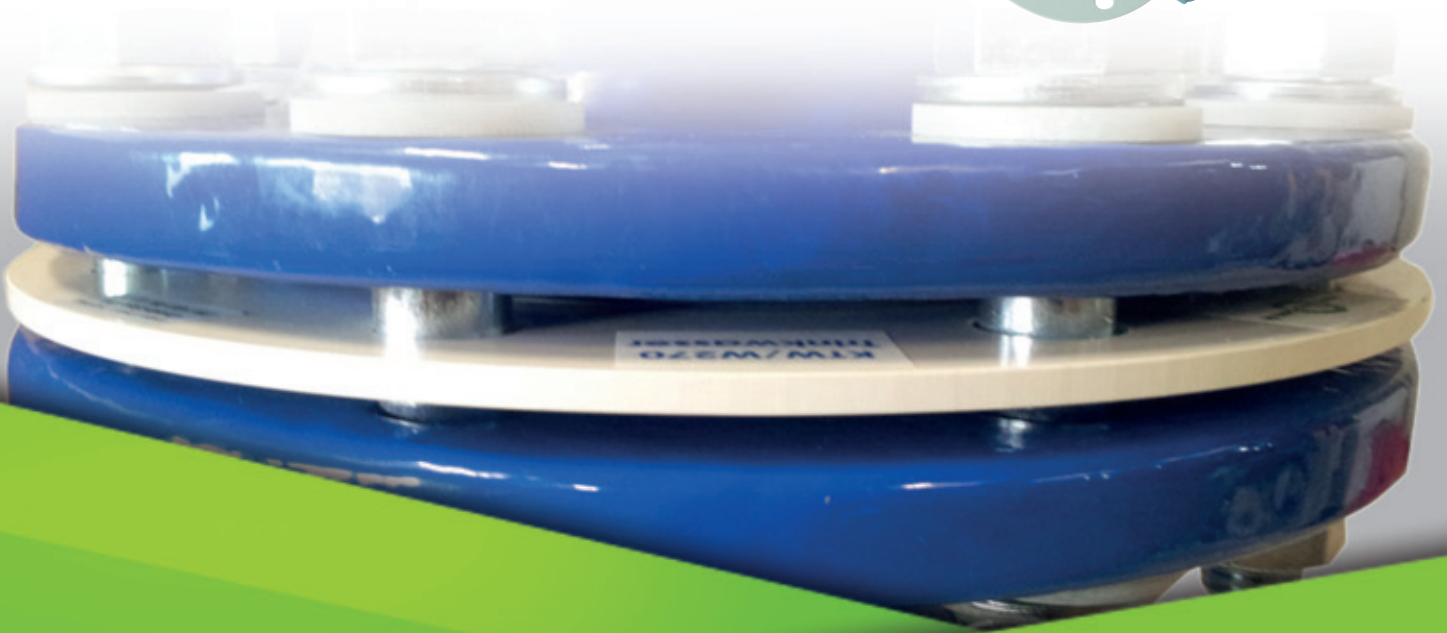

# Flange Isolating Technology 4 pipes

Isolating flange gaskets 4 pipes are especially designed for:

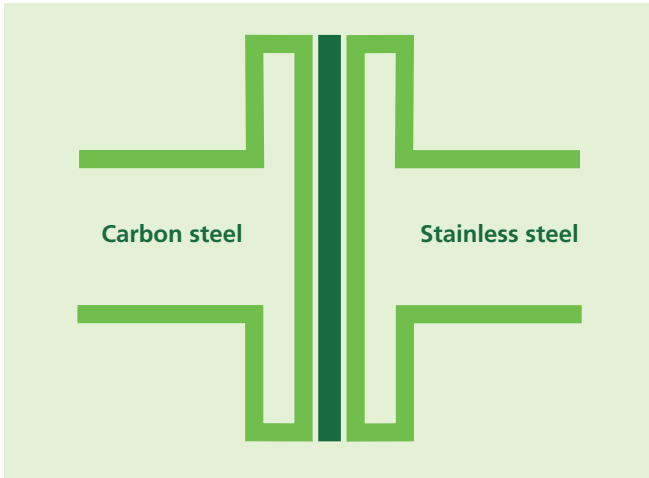

Contact corrosion between different types of steel

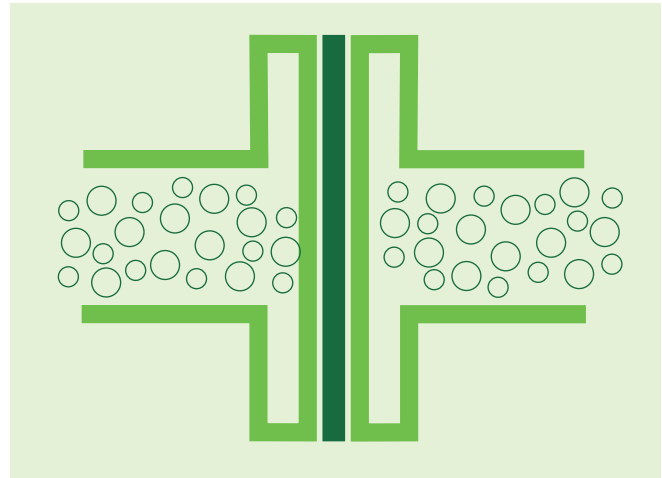

Different gasket materials for different substances

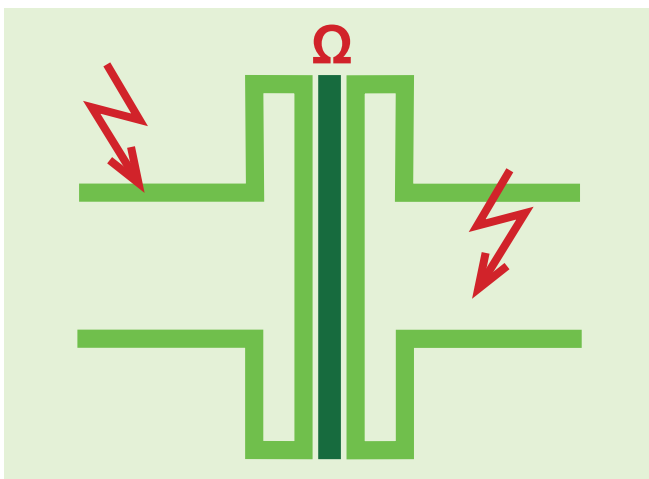

Electrical disconnection point to shut off pipeline parts, stations etc,

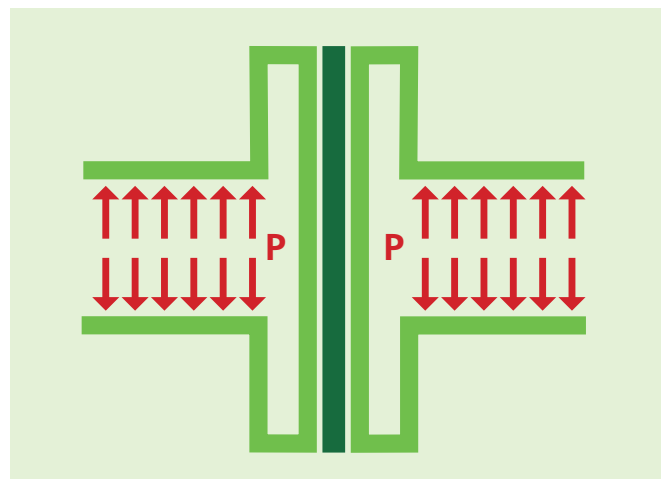

High pressure up to PN420 and bridging different flange designs

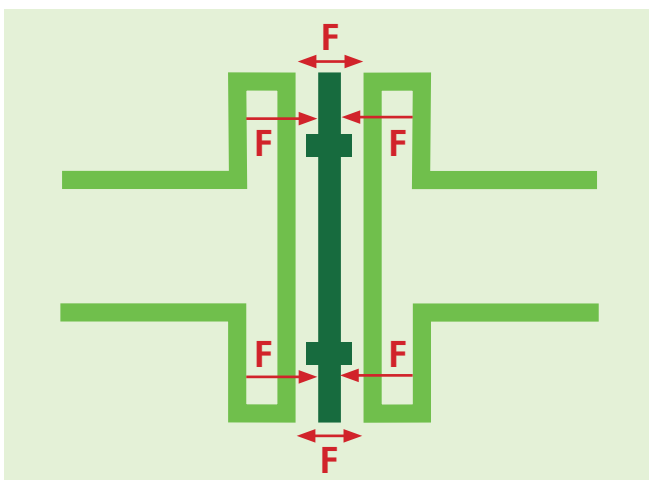

Indirect force gasket

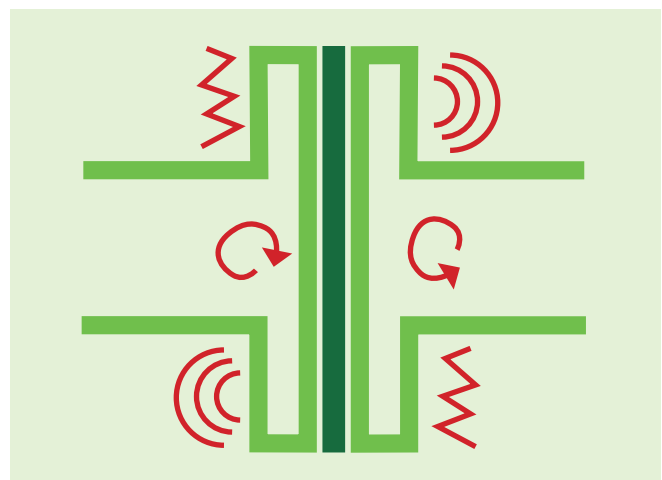

Bearing and transmission of mechanical forces like bending, torsion or vibration

# Flange Isolation Gaskets 4 pipes

## Combi-Seal-Gas G and Combi-Seal-Water TW High quality flange gasket and electrical isolation point



### Product Information

Combi-Seal flange isolation gaskets with bolt isolation kit serve as high quality sealing elements for use with, for example, gases. The Combi-Seal flange isolation gasket fulfils the requirement for an electrical separation point and prevents contact corrosions of the flange pipe segments.

The Combi-Seal flange isolation gaskets consist of a seal carrier with excellent mechanical, thermal and electrical properties, as well as grooves on both sides for the sealing elements. The Combi-Seal flange is intended to bear indirect flange bolt loads. The chambered graphite or silicone sealing material provides excellent long-term stability and reliability, and no retightening of the flange bolts is necessary.

### Usage

The Combi-Seal flange isolation gaskets are generally made for pipelines with DIN/ EN and ANSI flanges. They can be used for new installation as well as for replacements.

### Combi-Seal-G:

The retainer material is made of G10 epoxy resin with glass fabric and expanding graphite sealing material with excellent resistance to different substances, such as **gas, water, oils, chemicals and hot water**.

### Combi-Seal-TW:

The retainer material is made of high quality polyvinylchloride and permanently elastic silicone RTV1- 02 sealing material with good resistance against different media such as **water, non-concentrated acids and alkalines**.

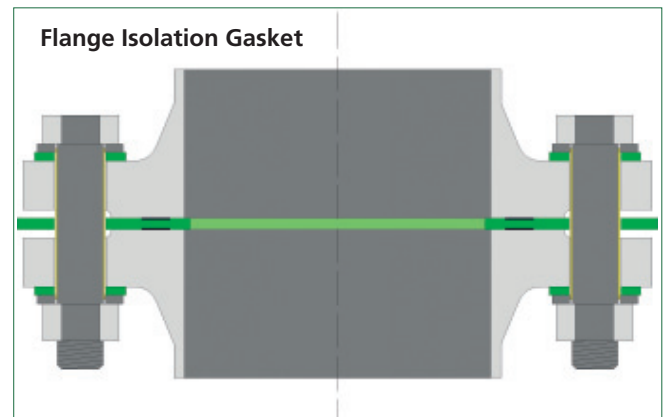

TA Luft KTW/W270  
drinking water

### Application area:

Industrial gas and drinking water networks, power stations, refineries, oil and gas plants, offshore installations, drinking water distribution, pharmaceuticals, utilities, chemical plants, heat exchanger manufacturers, shipyards, shipbuilders, offshore platforms.

### Approval and test

#### Application for drinking water:

**Combi- Seal- TW** is tested for drinking water in accordance with KTW/W270. (German regulations)

#### Application for gas systems:

**Combi-Seal-G** is tested for natural gas according to DIN-DVGW and TA-Luft.

**Resistant for 100% Hydrogen H2 pipelines.**

### Advantages

- maintenance free, no retightening of bolts
- easy to install
- low water absorption
- heavy duty flange isolation gaskets intended to bear indirect flange bolt force load on the seal
- blow-out-proof chambered seal in groove

The Combi-Seal flange isolation gaskets can be customized for any flange shape.

### Indirect flange bolt load

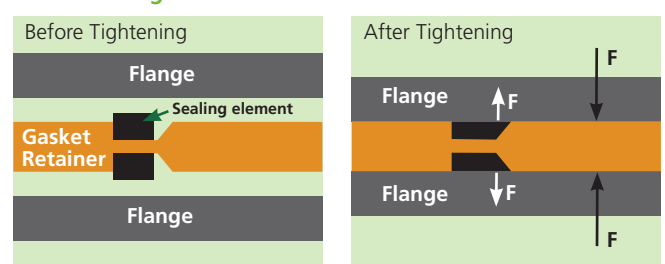



# Flange Isolation Gaskets 4 pipes

## Technical data

Please find the dimension and pressure rates in our price list or contact us.

Characteristics	Combi-Seal-G	Combi-Seal-TW	Test method
<b>Retainer</b>	Epoxy resin glass fabric	Polyvinylchloride (PVC)	
Operating temperature	-60°C up to 150 °C (302°F)	-40°C up to 80°C (176°F)	DIN/IEC 216/T1
Max. peak temperature ( < 1 hour)	180°C (356°F)	100°C (212°F)	DIN 44904
Colour	green	white	-
Thickness	4 mm ± 0.30 mm	4 - 6 mm* ± 0.10 mm	-
Spec. volume resistance	10ex16 Ω x cm	10ex15 Ω x cm	DIN/VDE 0303T30
Dielectric strength	13 kV/mm	27 kV/mm	DIN EN 60243-1
Compressive strength 20°C (68°F) / 180°C (356°F)	500/350 Mpa	130 Mpa	ISO 604
Flexural strength 80°C (176°F) / 180°C (356°F)	-/150 Mpa	80/- Mpa	ISO 1787/DIN 53452
Water absorption (10 mm thickness)	20 mg	< 0.01 %	ISO 62/1 / DIN 53495
<b>Sealing material</b>	Expanding graphite	Silicone RTV1 - 02	
Temperature resistance	500°C (932°F)	100°C (212°F)	-
Thickness	1.5 mm	2.0 mm	-
Density	1.25 g/cm <sup>3</sup>	1.2 g/cm <sup>3</sup>	DIN E28090T2 / DIN 53505
Hardness (Shore A)	-	55	DIN 53504S3D
Compression	> 20 %	-	ASTM F36A
Resilience	> 12 %	-	ASTM F36A
Ash content	< 2 %	-	DIN 51903

\* Up to DN 250 = 4mm, from DN 300 = 6 mm

### Combi-Seal-Flange Isolation

#### Type E (FF):

Sealing gasket with bolt holes according to the flange standard

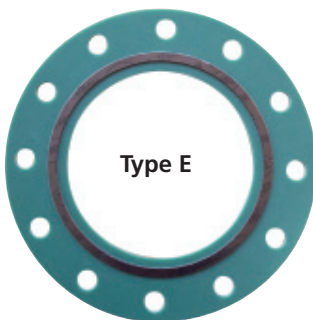

### Combi-Seal-Flange Isolation

#### Type F (IBC):

Sealing gasket lying in the inner bolt circle of flange bolt holes

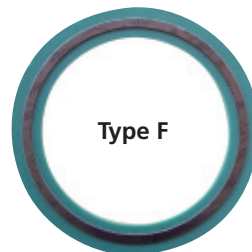

### Custom Made Combi-Seal-Flange Isolation

e.g. with extra large OD on request

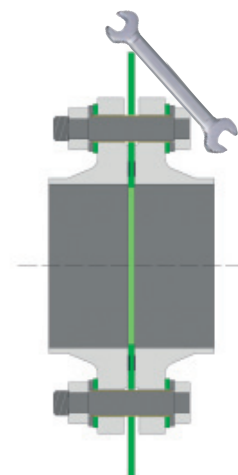

To avoid contact transmission through e.g. tools

## Flange Isolation Gaskets 4 pipes – Specials



### Combi-Seal-G200

The gasket is a composition of a G11 (Epoxy/Fibres) reinforced retainer and a graphite sealing element. The system is designed for **high temperatures** up to 200°C.

The Combi-Seal-G200 is designed for flange pressure ratings up to and including PN 100 as well as for ANSI flanges Class 600. In addition, the Combi-Seal-G200 is suitable for a wide variety of substances in the pipe, such as hot water, steam, gases, oils and chemicals.

**Resistant for 100% Hydrogen H2 pipelines.**

### Combi-Seal-G/F20

The Combi-Seal-G / F20 consists of a **20 mm** epoxy / glass reinforced (G10) **retainer** and an expanded graphite sealing element.

Weld neck flange



Female face flange



The Combi-Seal-G / F20 is generally available for flanges according to DIN / EN and ANSI standards. The Combi-Seal-G / F20 is ideal for **rehabilitation** work as well as for new installations.

The Combi-Seal-G / F20 is an ideal flange isolation for:

- a flange connection with double-sided **cavity-flanges** (eg DIN 2513)
- A flange connection with an increased gap distance
- A flange connection for double-sided **special flange with twisted sealing strip**
- The **replacement** of existing flange isolation of e.g. phenolic resin gaskets in **gas control stations**

The Combi-Seal-G / F20 is also available in **8 mm** or **16 mm** thickness.

Characteristics	Combi-Seal-G200	Combi-Seal-G/F20	Test method
<b>Retainer</b>	Epoxy/Glass	Epoxy/Glass	
Max. pipeline temperature	-30°C up to 200°C	-60°C up to 150°C	DIN/IEC 216/T1
Short term temperature	220°C	180°C	DIN 44904
Colour	light green	green	-
Thickness	4 mm ± 0.30 mm	20 mm ± 0.65 mm	-
Spec. volume resistance	10ex12 Ω x cm	10ex16 Ω x cm	DIN/VDE 0303T30
Electrical resistance	13 kV/mm	13 kv/mm	DIN EN 60243-1
Pressure resistance	500/350 Mpa	500/350 Mpa	ISO 604
Bending resistance	-/150 Mpa	-/150 Mpa	ISO 178
Water absorption	8 mg	20 mg	ISO 62/1/ DIN 53495
<b>Sealing element</b>	Expanded graphite		
Temperature resistance	500°C		-
Thickness	1.5 mm		-
Density	1.25 g/cm3		DIN E28090T2 / DIN 53505
Compression	> 12 %		ASTM F36A
Spring-back	> 20 %		ASTM F36A
Ash content	< 2 %		DIN 51303

The 4 pipes warranty only applies to faulty material. Checking the suitability of the product for the individual application is solely the responsibility of the user. 4 pipes does not grant any warranty for pre-installed or reused flange gaskets.

# Flange Isolation Gaskets 4 pipes

## Installation guide

Follow the installation instructions carefully to ensure correct functioning of the flange isolation.

1. The sealing surface of the flange has to be clean, free of grooves and edges (Flange surface according to DIN/ASME standard)
2. Insert the gasket carefully between the flange sealing surfaces
3. Lubricate bolts
4. Insert bolts incl. isolation washers and sleeve through the bolt hole and handtighten them:  
The steel washer will be placed on the bolt head and nut;  
the isolation washer will be placed directly on the flange.  
The bore holes of the flanges and isolation gasket have to be aligned with each other.  
Calculation of isolation sleeve length:  
 $2 \times \text{flange thickness incl. raised face} + \text{thickness of flange isolation gasket} + 2 \times \text{thickness of isolation washer} + 1 \times \text{thickness of steel washer} = \text{sleeve length}$
5. - Tighten bolt evenly (in three steps 30%-40%-30%)  
with a torque wrench according to the tightening torque table spec. below  
- Tighten bolt in a diagonally opposite sequence as shown in the picture on the right

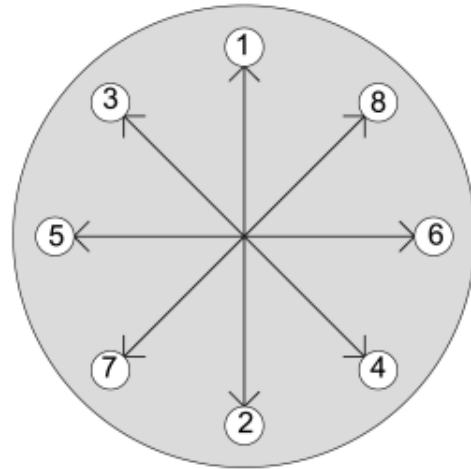

### Note:

- The flange bolts have to be greased/ lubricated generally for the installation
- For gas systems, it is advisable to use a PTFE based grease (common greases contain hydrocarbons which could cause incorrect gas measurement readings with a gasometer)
- **Warning:** For DIN flanges with bolt grades  $\geq 8.8$ , we advise to use 80% of the tightening torque. 100% tightening torque could deform the flange blades.

Tightening torque for flange bolts

Bolt size Metric	Bolt grade						Bolt size inch	Bolt grade A 193 B7
	5.6 Ck 35	8.8	10.9	12.9	A2 - 70	42 CrMo 4 A 320 L7M 40 CrMoV 47		
in Newtonmeter (Nm)								in Nm
M10	21	50	70	85	34	30	-	
M12	37	85	120	145	59	52	1/2 - 13 UNC	80
M16	90	210	300	350	145	128	5/8 - 11 UNC	160
M20	180	410	570	690	280	264	3/4 - 10 UNC	320
M22	240	550	780	940	380	360	7/8 - 9 UNC	480
M24	310	700	1,000	1,200	480	456	1 - 8 UNC	750
M27	450	1,050	1,480	1,775	-	672	1-1/8 - 7 UNC	1,050
M30	610	1,400	2,000	2,400	-	912	1-1/4 - 7 UNC	1,450
M33	830	1,900	2,700	3,250	-	1,240	1-3/8 - 6 UNC	1,900
M36	1,060	2,500	3,450	4,200	-	1,600	1-1/2 - 6 UNC	2,500
M39	1,380	3,200	4,500	5,400	-	2,080	1-3/4 - 8 UNC	4,600
M42	1,700	4,000	5,600	6,700	-	2,560	2 - 8 UNC	8,400
M45	2,120	5,000	7,000	8,400	-	3,200	2-1/4 - 8 UNC	9,800
M48	2,570	6,000	8,450	10,150	-	3,840	-	-
M52	3,310	7,750	10,800	13,000	-	4,960	-	-
M56	4,120	9,600	13,500	16,200	-	6,200	-	-
M60	5,130	12,000	16,800	20,200	-	7,680	-	-

Checking the suitability of the product for the individual application is solely the responsibility of the user.  
4 pipes does not grant any warranty for preinstalled or reused flange gaskets.



# Flange Bolt Isolation Accessories 4 pipes

## High-quality isolation materials for an electrical isolation point

### Product information

Special isolation materials for flange bolts and nuts fulfil the requirement for an electrical separation point and prevent contact corrosions of the flange joint. The bolt isolation set contains the required quantities of isolating washers, isolating sleeves and steel washers for the particular flange joint size / standard. One bolt requires: two isolating washers, two steel washers and one sleeve. The bolt isolation set protects both sides of the flange joint from possible electrical short circuits through the nut and bolt. The bolt isolation set can be delivered for all common flange standards, sizes and pressure rates.

### Usage

- New installation areas
- In connection with flange isolation gaskets
- Also suitable for replacement of existing flange joints during maintenance activities at the connection point

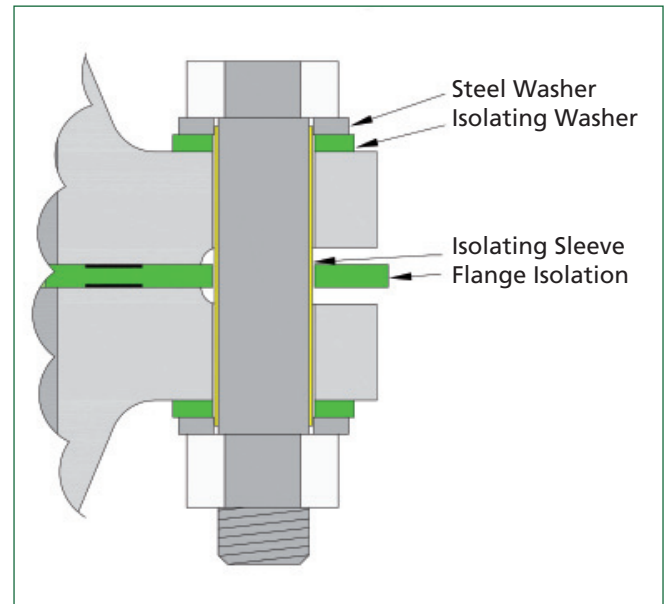

### Isolation bolt

Bolts are pre-coated with isolating epoxy resin / glass fibre material. One isolating bolt set contains two isolating washers, two steel washers and one nut. The isolation bolts steel quality and grade are made according to customer specification. (Standard bolt grade is 8.8 galvanized)

### Isolating washer

- G10 (standard)
- G11 (special)

### Isolating sleeve

- Mylar (standard)
- Nomex (special)

### Steel washer

- Steel ST37, galvanized DIN 126 (standard)
- Stainless steel V4A (special)

### Standard Isolating Kit =

Isolating Washer: G10  
Isolating Sleeve: Mylar  
Steel Washer: steel galvanized

### Special (selection of combination) Isolating Kit =

Isolating Washer: G10 or G11  
Isolating Sleeve: Mylar or Nomex  
Steel Washer: steel galvanized or stainless steel

### Technical data

Please find the dimension and pressure rates in our price list or ask us.



Characteristics:	G10	G11	Mylar	Nomex	Isolating Bolt
Material	Epoxy resin glass fibre	Epoxy resin glass fibre	Spiral wound polyester	Armid spiral wound paper	Epoxy resin glass fibre
Operating temperature	-60°C bis +130°C	-60°C bis +180°C	-60°C bis +150°C	-196 °C bis +200 °C	200°C
Water absorbtion	<0.1 %	<0.1 %	<0.8 %	< 0.1%	<20 mg
Dielectrical strength	20.000 V/mm	60.000 V/mm	270.000 V/mm	22.500 V/mm	min. 5 KV/mm

# Flange Bolt Isolation Accessories 4 pipes

## Installation guide

Follow the installation instructions carefully to ensure correct functioning of the flange isolation.

1. The sealing surface of the flange has to be clean, free of grooves and edges (Flange surface according to DIN/ASME standard)
2. Insert the gasket carefully between the flange sealing surfaces
3. Lubricate bolts
4. Insert bolts incl. isolation washers and sleeve through the bolt hole and handtighten them:  
The steel washer will be placed on the bolt head and nut; the isolation washer will be placed directly on the flange. The bore holes of the flanges and isolation gasket have to be aligned with each other.  
Calculation of isolation sleeve length:  
2 x flange thickness incl. raised face + thickness of flange isolation gasket + 2 x thickness of isolation washer + 1x thickness of steel washer = sleeve length
5. - Tighten bolt evenly (in three steps 30%-40%-30%) with a torque wrench according to the tightening torque table spec. below  
- Tighten bolt in a diagonally opposite sequence as shown in the picture on the right

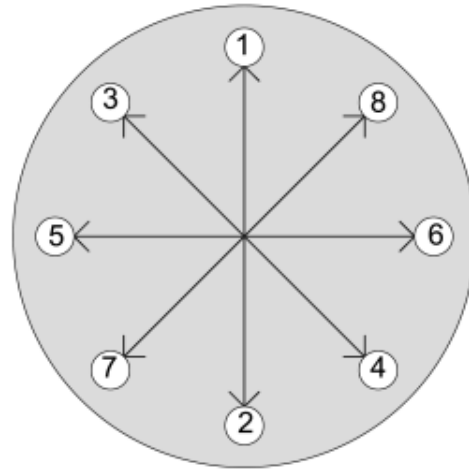

### Note:

- The flange bolts have to be greased/ lubricated generally for the installation
- For gas systems, it is advisable to use a PTFE based grease (common greases contain hydrocarbons which could cause incorrect gas measurement readings with a gasometer)
- **Warning:** For DIN flanges with bolt grades  $\geq 8.8$ , we advise to use 80% of the tightening torque. 100% tightening torque could deform the flange blades.

Tightening torque for flange bolts

Bolt size Metric	Bolt grade						Bolt size inch	Bolt grade A 193 B7
	5.6 Ck 35	8.8	10.9	12.9	A2 - 70	42 CrMo 4 A 320 L7M 40 CrMoV 47		
in Newtonmeter (Nm)								in Nm
M10	21	50	70	85	34	30	-	
M12	37	85	120	145	59	52	1/2 - 13 UNC	80
M16	90	210	300	350	145	128	5/8 - 11 UNC	160
M20	180	410	570	690	280	264	3/4 - 10 UNC	320
M22	240	550	780	940	380	360	7/8 - 9 UNC	480
M24	310	700	1,000	1,200	480	456	1 - 8 UNC	750
M27	450	1,050	1,480	1,775	-	672	1-1/8 - 7 UNC	1,050
M30	610	1,400	2,000	2,400	-	912	1-1/4 - 7 UNC	1,450
M33	830	1,900	2,700	3,250	-	1,240	1-3/8 - 6 UNC	1,900
M36	1,060	2,500	3,450	4,200	-	1,600	1-1/2 - 6 UNC	2,500
M39	1,380	3,200	4,500	5,400	-	2,080	1-3/4 - 8 UNC	4,600
M42	1,700	4,000	5,600	6,700	-	2,560	2 - 8 UNC	8,400
M45	2,120	5,000	7,000	8,400	-	3,200	2-1/4 - 8 UNC	9,800
M48	2,570	6,000	8,450	10,150	-	3,840	-	-
M52	3,310	7,750	10,800	13,000	-	4,960	-	-
M56	4,120	9,600	13,500	16,200	-	6,200	-	-
M60	5,130	12,000	16,800	20,200	-	7,680	-	-

Checking the suitability of the product for the individual application is solely the responsibility of the user. 4 pipes does not grant any warranty for preinstalled or reused flange gaskets.



Pipeline Accessories

## Cable Duct Fittings 4 pipes



# Cable Duct Fittings 4 pipes



### Product information

- 4 Pipes cable duct-compression fittings are characterised by:
- 16 bar Water tight, air tight, Resistant to corrosion and most chemicals.
  - With their orange nuts and the transparent body, they are specially designed for telecommunication applications.

Diameter [mm]	Unit Weight [kg]	Box small	Box big
40	0,232	25	60
50	0,326	15	32
63	0,457	12	24

### Dimensions

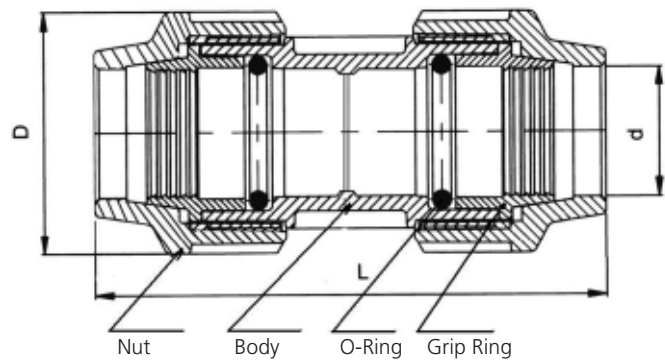

DN	L (closed) (mm)	L (open) (mm)	d (mm)	D (mm)
40	148,4	177,0	42,0	73,9
50	169,2	209,6	51,6	84,0
63	183,3	221,4	64,2	100,4

### Materials

- Body: Polypropylene – transparent (black or blue on request)  
 Nuts: Polypropylene – Orange (black or green on request)  
 Grip Ring: Acetal – White  
 Seal: Nitrile rubber O-RING – Black

Cable duct dimensions should be in compliance with standards for PE Pipes e.g. EN12201 etc.:

Compression fittings are made of elements manufactured with injection moulding methods. The highest quality of the products is ensured by a modern processing line and possibility of an in-process control of the material and product parameters.

DN (mm)	Outside Diameter	Max. Ovality	min. Wall Thickness	
	mm	mm	SDR13,6 [mm]	SDR11 [mm]
40	40,0 - 40,4	1,4	3,0	3,7
50	50,0 - 50,4	1,4	3,7	4,6
63	63,0 - 63,4	1,5	4,7	5,8

### Performance

Pressure rating  $\leq$  16 bar, for 2 hours, at  $20 \pm 2^\circ \text{C}$

Temperature ranges:

- storage and transport from  $-40^\circ \text{C}$  to  $+85^\circ \text{C}$
- assembly from  $-5^\circ \text{C}$  to  $+50^\circ \text{C}$
- operation from  $-10^\circ \text{C}$  to  $+85^\circ \text{C}$





## Assembly instruction of compression fittings 4 pipes

In order to ensure the quality of the cable duct connection, assembly of compression fittings shall be carried out as follows:

### for Ø 20 mm - Ø 50 mm

Cut the pipe at 90° to its centerline using a pipe cutter, chamfer the pipes end, moisten end of pipe by water or soap.

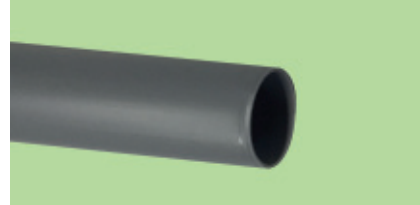

Slacken the ring nut and insert the pipe until the O-ring and internal pipe slide stop.

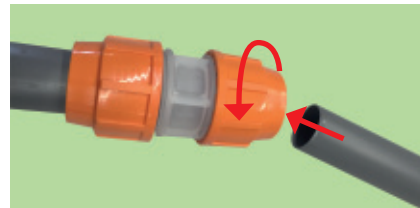

Hand Tighten the ring nut.



### für Ø 63 mm - Ø 110 mm

After preparing pipe ends, unscrew the fitting, then put all internal components: the ring nut, rip ring and the O-ring on the pipe end.

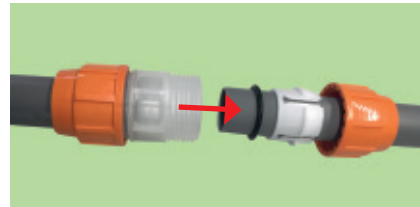

Push the pipe into the fitting until it reaches the stop. Insert the O-ring and the grip ring in to the pipe.

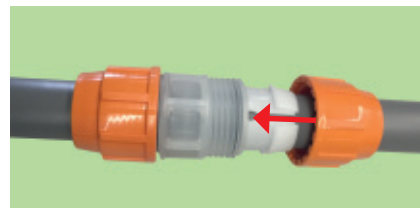

Tighten with a strap/chain wrench in order to complete the assembly.



**Note! The pipes and connectors shall be kept clean during assembly.**

The 4 pipes warranty is limited to the replacement of faulty material. The user is fully responsible for the individual application he is using the product for.



Pipeline Accessories

## Cleaning Pigs 4 pipes





Foam pigs can be used to clean pipelines reliably and cost-effectively.

### Product information

Foam pigs are mainly used to clean all types of pipelines. The pig cleaning method removes deposits, rust, encrustation and residue from the pipeline. Foam pigs eliminate unwanted build-ups causing reduction of the pipe internal diameter. Foam pigs can also be used for other purposes, such as drying (e.g. after hydrostatic tests), draining, separating and filling of pipes with various substances.

To optimize the cleaning effect, foam pigs are available in several designs, depending on the application. Foam pigs can easily pass through pipe bends, T-pieces, valves and narrow sections.

### Moving the foam pig through the pipe

- Use compressed air
- Use water pressure
- Use the flow of the substance in pipe
- Pull with a rope

### For pipelines made of

- Steel
- Plastic
- Cast iron
- Vitrified clay
- Pipes with internal lining

### Advantages

- Fast and easy cleaning
- Reliable cleaning for long pipe distances
- Cost efficient
- No drop in performance of pipeline

### 4 pipes foam pigs are available in three densities:

- Super Soft:** 24 – 32 kg/m<sup>3</sup> (1 ½ - 2 lbs. cu. Ft)  
polyurethane foam, colour: Yellow
- Medium Soft:** 80 – 112 kg/m<sup>3</sup> (5 - 7 lbs. cu. Ft)  
polyurethane foam, colour: Blue
- Hard:** 128 – 160 kg/m<sup>3</sup> (8 - 10 lbs. cu. Ft)  
polyurethane foam, colour: Red

### Super Soft, Yellow

#### Pig outer diameter (D) compression: 50 %

Cleaning of low-level and undetermined deposits, final drying after hydrostatic testing. Pig for min. pipe bend radius type 3 (1.5 d)



Type **PM – S**  
with thin PU-coated base plate



Type **PM – SX**  
crosswise PU-coated

### Medium Soft, Blue

#### Pig outer diameter (D) compression: 10 - 25 %

Cleaning for mid-level and soft deposits, drying, for long pipelines, for complex pipelines with a lot of bends, valves, fittings, etc. Removal of slight corrosion/ rust, dewatering, filling and separation of liquids. Pig for min. pipe bend radius type 3 (1.5 d)



Type **PM – M**  
with PU-coated base plate,  
Pig outer diameter  
compression: 25%



Type **PM – MX**  
crosswise PU-coated,  
Pig outer diameter  
compression: 20%



Type **PM – MV**  
fully PU-coated, Pig outer diameter  
compression: 10%  
other steel-brush qualities (e.g. for stainless steel) on request

# Cleaning Pigs 4 pipes



Type **PM – MXB**  
 spiral formed galvanized steel wire brushes and PU-coated, pig outer diameter compression: 10%  
 other steel-brush qualities (e.g. for stainless steel) on request



Type **PM – HXC**  
 spiral formed abrasive coated paper and PU coated, pig outer diameter compression: 10%



Type **PM – MXC**  
 spiral formed abrasive coated paper and PU-coated, pig outer diameter compression: 15%



Type **PM – HVS**  
 fully coated with galvanized steel wire brushes, pig outer diameter compression: 5%

## Hard, Red Pig outer diameter (D) compression: 5 - 25 %

Cleaning of heavy deposits, drying of very long pipelines, removal of severe corrosion / rust, filling and separation of liquids. Pig for min. pipe bend radius type 3 (1.5 d)



Type **PM – H**  
 with PU-coated base plate, pig outer diameter compression: 20%



Type **PM – HX**  
 crosswise PU-coated, pig outer diameter compression: 15%



Type **PM – HV**  
 fully PU-coated, pig outer diameter compression: 10%



Type **PM – HXB**  
 spiral formed galvanized steel wire brushes and PU-coated, pig outer diameter compression: 5%  
 other steel-brush qualities (e.g. for stainless steel) on request

Foam pig dimensions: Mid and Hard				Foam pig dimensions: Super Soft	
inch	DN	D mm*	L mm*	D mm*	L mm*
2.0	50	56	120	85	100
2.5	65	69	120	85	100
3.0	80	82	145	100	135
4.0	100	108	200	125	180
5.0	125	133	245	155	225
6.0	150	163	320	180	265
7.0	175	189	370	235	355
8.0	200	213	420	235	355
10.0	250	263	520	290	445
12.0	300	315	610	345	535
14.0	350	350	700	395	605
16.0	400	398	710	440	660
18.0	450	448	720	490	745
20.0	500	500	790	540	830
22.0	550	552	850	590	915
24.0	600	604	935	640	1005
26.0	650	660	1010	690	1090
28.0	700	700	1100	740	1175
30.0	750	755	1170	795	1265
32.0	800	780	1240	845	1350
34.0	850	840	1360	920	1435
36.0	900	905	1400	970	1520
40.0	1000	1008	1550	1020	1610

\*The dimensions of cleaning pigs may differ acc. to different pipe qualities and sizes. Other dimension on request.

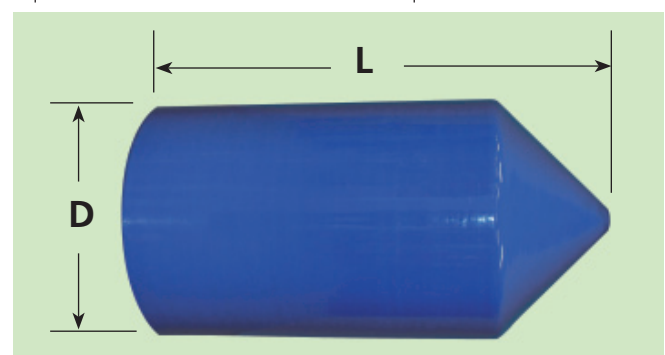



## Cleaning Pigs 4 pipes



### Individual pig types

Foam pigs can be manufactured on request as follows:

- Pigs with **loop** on one or on both ends of the pig. (For a rope connection).
- **Conical at both ends, so foam pig can move in both directions**
- **With special diameters**
- **Brushes made of nylon or stainless steel**
- Pig with cavity, for installing a transmitter inside the pig
- **Foam pigs with attached collar, on request**

### Checklist to select the right cleaning pig

Pipe inner diameter (DN or ID)	
Pipe quality, for e.g. PE, steel etc.	
Pipe length	
Dimension of bends, valves, fittings, etc.	
How will the pig move through pipe (e.g. water or air pressure)?	
How will the pig enter and exit the pipe?	
Type and extent of deposits (e.g. rust, sand, mud, grease, limescale)	
How much pressure or force is used to move pig through pipe?	



Pipeline Accessories

Tools 4 pipes



## Outside Chamfering Tool 4 pipes



### Product description

The outside chamfering tool 4 pipes is an innovative and high-quality tool for safe chamfering of PE pipes in metric dimensions **from 20 to 110 mm outside diameter**.

With a perfect chamfer, PE pipes can be pushed into fittings safely without damaging their inside seals with any sharp edge.

### Features:

- Limit-stop ensures exact chamfer for every size
- Prevents any inexact "sharpening" of the pipe end
- Only two tools for the dimensions 20 to 110 mm:  
20-25-32-40-50-63 mm  
and 75-90-110 mm
- Just one complete turn necessary
- Blade made of high-quality steel
- Body made of high-tech plastic
- Light and easy to handle
- Cost effective
- Highly impact resistant

### Outside chamfering tools 4 pipes:

**Art. No. 20301** – 20-25-32-40-50-63 mm

**Art. No. 20306** – 75-90-110 mm

### Replacement blades set per 10 pcs.:

**Art. No. 20302**

Special colours and individual labeling on request.



Application video

## Inside Chamfering Tool 4 pipes



### Product description

The inside chamfering tool 4 pipes is an innovative and high-quality tool for the simple chamfering of plastic pipes (PE and PEX) for ODs from 20 mm to 63 mm.

By using this tool for exact inner chamfering, it is possible for support sleeves and fittings (e.g. compression fittings) to be inserted precisely into the pipe. Sealing elements are not damaged at the pipe edge.

### Special areas of application:

- District heating compression fitting technology on PEX pipes
- Gas: installation of inner support sleeves with mechanical fitting technology

### Features:

- Central conical structure ensures exact chamfering
- Protective housing (minimizes risk of injury)
- Light and easy to handle
- Cost effective
- Heavy duty thanks to the housing made of PP high-performance plastic
- Just one complete turn necessary
- Only one tool for the pipe dimensions: D 20-25-32-40-50-63
- Easy replacement of the blades possible

### Inside chamfering tool 4 pipes D 20-63:

Art. No. 20315

### Replacement blades set á 10 pcs.:

Art. No. 20302



Special colours and individual inscriptions on request.



Application video





### Product information

The Cleaning Strap 4 pipes is especially designed to clean encrusted dirt from the outside of buried ductile iron or steel pipes. The cleaning strap 4 pipes is perfect for easy and reliable manual cleaning of old pipes, especially when they have been unearthed before cutting or the application of repair clamps, tapping clamps or multi-joints.

- Easy and reliable cleaning of metallic pipes surfaces, especially on the hard-to-reach underside of the pipe
- Self cleaning, robust, **circular cleaning teeth** of hardened steel for an optimised **cleaning effect in both directions**
- **Anti-static, fibre-reinforced**, washable strap, 40 mm wide
- Fast and easy cleaning of the strap surface after usage
- Ergonomic „rolling“ handles made of coated steel, **with a built-in shortening device**
- Strap can be hooked onto the shortening device, making it easier to use for smaller pipe dimensions



Two sizes:

- **Length 1 metre** – for pipe DN 65 up to DN 300  
Art.-No. 20310
- **Length 2 metre** – for pipe DN 300 up to DN 600  
Art.-No. 20311



Installation video

# Uni-Key Adaptor 4 pipes



**Standard  
Uni-Key Adaptor**

**Mini  
Uni-Key Adaptor**

## Product information

The Uni-Key Adaptor 4 pipes is an innovative tool to open or close all kinds of valves, such as slides, hydrants, flaps, ball valves, etc.

- **In case of emergency, it is no longer a problem if the required stem square cap is missing, broken or rusty, or if the dimensions are unusual.**
- Regardless of what kind of adaptor, stem square cap or stem hexagonal cap the technician uses to operate the valve, the Uni-Key Adaptor fits every time (even on contours) and can be used with a standard hydrant wrench 27 x 32 mm.
- Hardened special steel pins attach themselves to all contours and grip them securely.
- The housing of the Uni-Key-Adaptor 4 pipes consists of thick-walled, coated steel, which ensures that it functions well, even with high torsional forces.
- It is no longer necessary to have a lot of different valve wrenches / adaptors in the service vehicle.
- Two sizes are available:
  - the standard size with 80 mm outer diameter for all standard fittings, gate valves and hydrants
  - the smaller size of 60 mm for shaft covers for house connections – also fits for the standard 27x32 mm head



## Technical data

	Standard Uni-Key-Adaptor	Mini Uni-Key-Adaptor
Material	Steel	Steel
Corrosion protection	Powder coating	Powder coating
Outer diameter	80 mm	60 mm
Height	360 mm	340 mm
Dimensions of square head (Measurements of hydrant wrench)	27 X 32 mm	27 X 32 mm
Article number 4 pipes	20320	20321
Height of round body	195 mm	195 mm
Internal dimensions square	50 x 50 mm	31 x 31 mm
Number of square steel pins	64 pieces	25 pieces

**Interior with hardened special steel pins.  
Regular lubrication is recommended.**

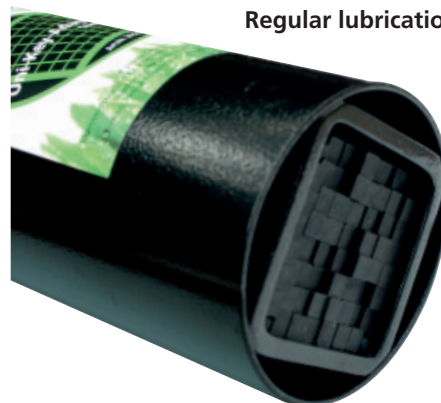

**Function**



Pipeline Accessories

## Magnetic Cover Lifters and Accessories 4 pipes





# Magnetic Manhole Cover Hammer 4 pipes

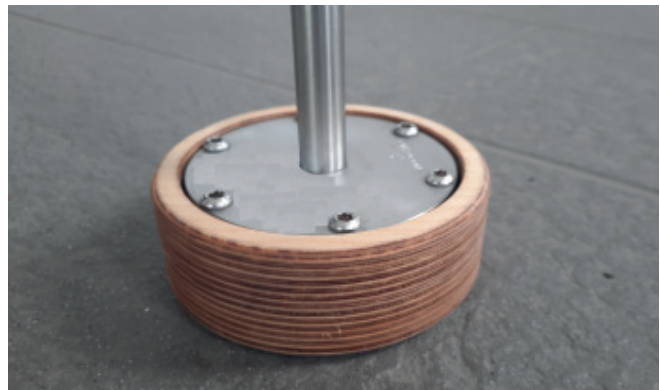

## Product description

The magnetic manhole cover hammer 4 pipes is a hammer which makes the loosening and lifting of manhole covers significantly easier. At one end of the stainless steel shaft, a hammerhead with a special shaped nozzle is attached.

The tip of the hammer side is perfect for opening, loosening or levering up manhole covers for valves, underground hydrants etc.

The other end of the shaft is equipped with a **130 kg** or **250 kg power magnet**. The magnet makes the lifting and turning of the manhole covers much easier than traditional methods.

This product is ideal for improved ergonomics when lifting. The operator can keep standing upright during the opening process, reducing the chance of any damage to the spine. The tool is suitable for metallic manhole covers, for example those made from cast iron or carbon steel.

## PAY ATTENTION TO SAFETY INSTRUCTIONS

### Technical data

Magnet type	Permanent magnet	
Magnet diameter	60 mm	100 mm
Shaft length	670 mm	
<b>Magnetic holding force</b>	<b>130 Kg</b>	<b>250 Kg</b>
Shaft material	S304 Stainless Steel	
Article number 4 pipes	20300	20312



Application video



## Magnetic Cover Lifter MD 400 4 pipes

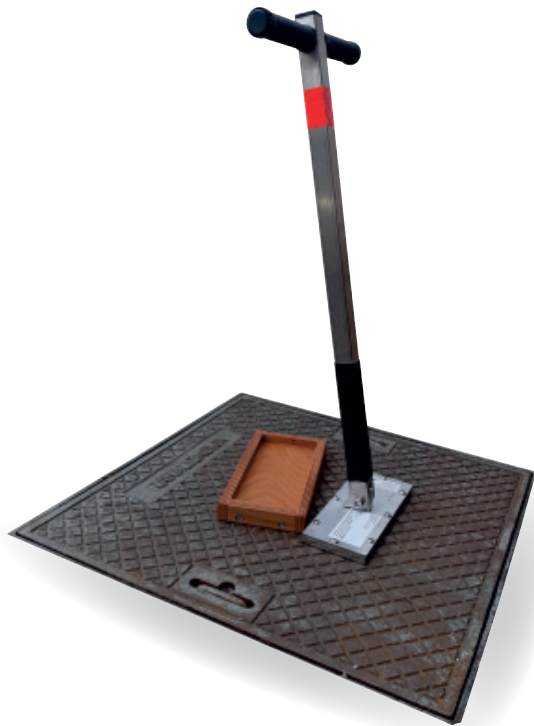

The **magnetic cover lifter MD 400** is a universal magnetic lifter for opening all kinds of manhole covers and grids made of cast iron and steel. With a weight of less than 5 kg, it is equipped with a magnet, which has a lifting capacity of 400 kg - an indispensable and effective tool that is easy to handle.

The large magnet with an area of 240 cm<sup>2</sup> has an exceptional magnetic holding force, also on profiled and dirty surfaces. That means that in most cases, its use is not limited by its magnetic force, but by the power of the user, taking into consideration the work and safety regulations.

With the magnetic cover lifter MD 400, steel and cast-iron manhole covers can be lifted, tilted or pulled.

The "self-standing" function saves you having to bend down to pick up the tool.

The flexibly flanged handle allows the cover lifter to be tilted sideways to pull off the manhole cover.

All metal parts are made of stainless steel, ensuring durability and easy maintenance.

The magnetic cover lifter MD 400 comes with a wooden protective cap to avoid accidental magnetic contact when it is not in use.



### Technical data

Magnet type	Permanent magnet
Magnet size	240 cm <sup>2</sup>
Tool height	750 mm
<b>Magnetic holding force</b>	<b>400 kg</b>
Material	Stainless steel
Weight	4.7 kg
Article number 4 pipes	20313

# Adapter Lever for Magnetic Cover Lifter MD 400



Application video

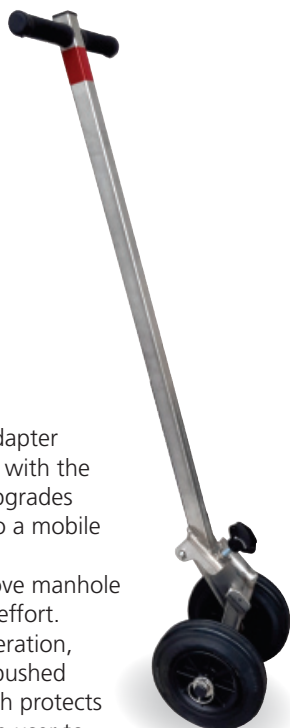

The adaptor lever is a lever adapter with wheels designed for use with the Magnetic Lifter MD 400. It upgrades the MD 400 magnetic lifter to a mobile lifting cart.

It makes it easy to lift and move manhole covers with minimal physical effort. Thanks to the lever-based operation, only the handle needs to be pushed down to raise the cover, which protects the user's back and allows the user to move the cover safely and with minimal effort.

The flexible design of the fastening system enables quick and easy assembly or disassembly of the adapter as well as flexible adjustment of the length of the magnetic tool's lever to the size of the cover.

Large solid rubber wheels make it easier to move the cover, even on uneven surfaces.

### Advantages:

- Quick and easy assembly on the magnetic cover lifter
- All metal parts made of stainless steel
- Large solid rubber wheels
- Rubber grips
- Reflective safety foil
- Without loose parts



### Technical data

Diameter tyres	200 mm
Tool dimensions	120 x 30 x 20 cm
Tool weight	6.3 kg
Tool weight with Magnetic Manhole Cover Lifter MD 400	approx. 11 kg
Material	Stainless steel
Article number 4 pipes	20314





Pipeline Accessories

Storage and  
Transport Systems  
4 pipes

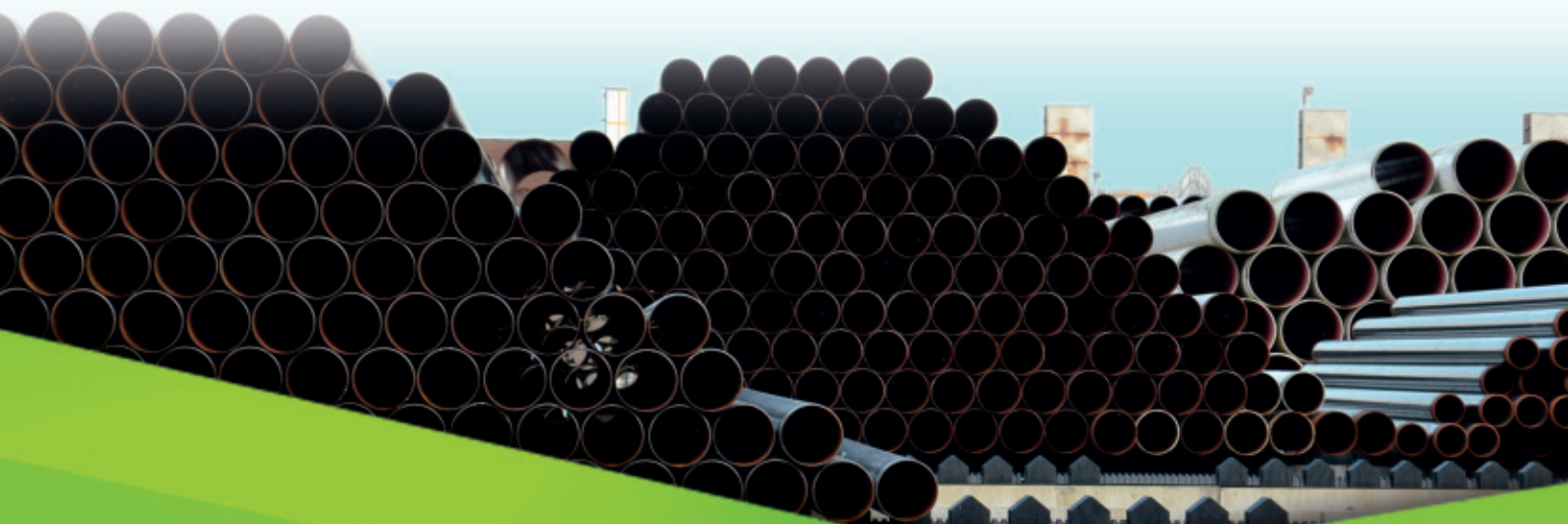

## Pipe Stop 4 pipes

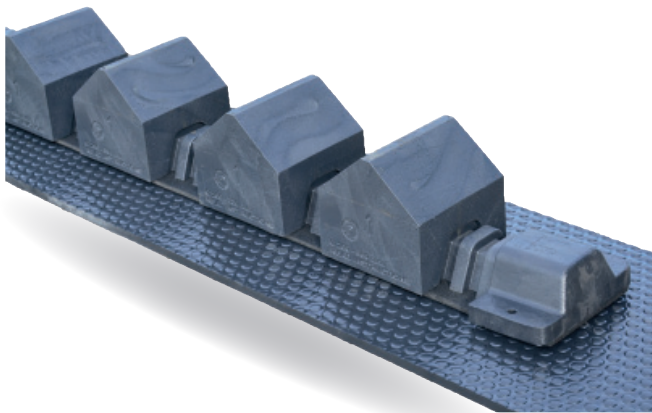

### General information

The Pipe Stop system is a storage system for stacking pipes safely. It consists of rail segments with a length of 4 metres that are steel reinforced. These rails can be endlessly connected, to form rail of any desired length. The connection is made using specially-designed connectors. To support a complete pipe stack, at least 2 parallel rails are needed.

LDPE (low density polyethylene) Pipe Stop blocks are placed on top of the rails. Per rail two Pipe Stop blocks are needed for the correct support of one pipe. The pipes will only be supported by the Pipe Stop blocks and are not in contact with the rail. To ensure that the pipes are correctly supported, it is of great importance that the Pipe Stop blocks are positioned correctly. For every pipe diameter, there is a proper block configuration, given in this instruction manual. Therefore the position of the Pipe Stop blocks on the rails should always be regarded with great care. In case the prescribed exact position of the Pipe Stop blocks is unclear, always contact 4 pipes for assistance.

The Pipe Stop system is capable of supporting pipes from Ø 200 mm to 2575 mm (7.87" – 101"). To cover this complete range of pipe diameters, there are four different types of Pipe Stop blocks available. Pipe Stop Block Type A, Type B, Type C and Type D. Pipe Stop Block Type A is designed to support pipes from Ø 200 mm up to Ø 406 mm, Pipe Stop Block Type B is designed to support pipes from Ø 380 mm up to Ø 670 mm, Pipe Stop Block Type C for pipes from Ø 660 mm up to Ø 1590 mm and Pipe Stop Block Type D for pipes from Ø 1030 mm up to Ø 2575 mm. Pipe Stop Block Type C and Type D have support areas on the side, whereas Pipe Stop Block Type A and Type B are designed to support pipes on both sides of the Pipe Stop block.

### Pipe Stop offers the following advantages:

- Application range: 8" - 102"
- Safe for coated pipes
- Ensures an ideal support for the pipe
- High durability and reliability
- Suitable for all weather conditions
- Easily adjustable
- Durable, resistant to oil and moisture
- Less material stress, improved roundness of the pipe
- All forces are calculated with an added safety margin to eliminate uncertainties

### Additional information:

- Application temperature: -45°C to +60°C (-49°F / 140°F)
- For a temperature up to 40°C (104°F) a maximum load on 2 supporting lines: 50,000 kg (110,180lbs)  
(Each pipe is supported on min. 4 positions)
- For a temperature up 60°C (140°F) a maximum load on 2 supporting lines: 40,000kg (88,185lbs)  
(Each pipe is supported on min. 4 positions)
- Pipe Stop Measuremate available for efficient installation

### Material specifications

Rails	Steel reinforced PE-Compound 4.031 m (13.2ft) / 46.5kg (102.5 lbs)
Connectors parts	Steel
PS50 Block type A	PE-Compound, 92°shore A; 5.43kg (12 lbs) For pipe diameters: 200 mm - 406 mm (7.87" - 16")
PS50 Block type B	PE-Compound, 92°shore A; 12.56 kg (27.7 lbs) For pipe diameters: 380 mm - 670 mm (15" - 26.4")
PS50 Block type C	PE-Compound, 92°shore A; 8.19 kg (18.06 lbs) For pipe diameters: 660 mm - 1590 mm (25.96" – 62.6")
PS50 Block type D	PE-Compound, 92°shore A; 16.33 kg (36lbs) For pipe diameters: 1030mm - 2575 mm (40.54" – 101")
Product range	200.0 mm - 2575 mm (7.87" – 102")

### Application

The connectable bottom rails are placed on a flattened surface. The blocks can easily be positioned over the rails.

**Further information on installation, storage and configuration can be found at:**  
[www.4pipes.de/pipestorage](http://www.4pipes.de/pipestorage)



## Pipe Stop 4 pipes

<p><b>Pipe Stop Rail</b> The length of the Rail: 4013 mm Weight of the Rail: approx. 46.5 kg <b>Art. No. 59050</b></p>		<p><b>Pipe Stop End Cap</b> Weight of the End Cap: approx. 1.1 kg <b>Art. No. 59059</b></p>	
<p><b>Pipe Stop Block A</b> Diameter range: Ø 200 - 406 mm Weight of the Block: approx. 5.5 kg <b>Art. No. 59055</b></p>		<p><b>Pipe Stop Connector</b> Weight of the Connector: approx. 0.6 kg <b>Art. No. 59065</b></p>	
<p><b>Pipe Stop Block B</b> Diameter range: Ø 380 - 670 mm Weight of the Block: approx. 12.5 kg <b>Art. No. 59056</b></p>		<p><b>Pipe Stop Installation Tool</b> Weight of the Installation Tool: approx. 0.4 kg <b>Art. No. 59066</b></p>	
<p><b>Pipe Stop Block C</b> Diameter range: Ø 660 - 1590 mm Weight of the Block: ± 8.2 kg <b>Art. No. 59057</b></p>		<p><b>Pipe Stop Anti-Skid</b> Weight of the Anti-Skid: approx. 1.4 kg/metre <b>Art. No. 59068</b></p>	
<p><b>Pipe Stop Block D</b> Diameter range: Ø 1030 - 2575 mm Weight of the Block: ± 16.2 kg <b>Art. No. 59058</b></p>			

## Pipe Carrier Premium 4 pipes



### General information

The Pipe Carrier Premium is a suitable solution **for storage or transport** of pipes with a range from Ø 114.3 up to Ø 508 mm (4.5" – 20"). **It facilitates safe and efficient pipe handling and transport.**

The Pipe Carrier Premium improves pipe storage and pipe transport operations. The logistic processes of tubes and pipes are simplified with 5 carrier types that cover the above-mentioned diameter range. Each carrier has a length of 1.225 m. Two carriers beside each other use the full truck width (2.45 m) resulting in an optimal truck load configuration. Also, maximum safety during transport is ensured since the Carriers are designed to be tilt-proof. With the Pipe Carrier Premium, pipes are supported sideways. This results in less stress for pipe and coating due to a better distribution of forces. An added advantage is that each model of the Pipe Carrier Premium is suitable for a certain diameter range. Less carriers are needed to cover different sizes.

Pipe Carrier Premium is made from **UV-stabilized recycled LDPE with a high load-bearing capacity**. The LDPE surface is suitable for any coating layer and no parts are sticking out, making them **safe for coated pipes**. The system is **weather proof, reusable** and **highly durable for short and long-term storage**.

Always contact 4 pipes in case of doubts or uncertainties during installation, operation and maintenance of the Pipe Carrier Premium parts.

### Pipe Carrier Premium offers the following advantages:

- Application range: 4" - 20"
- Each carrier is suitable for a range of pipe diameters
- For storage and transport
- Two carriers cover truck width (2.45 m)
- Safe for pipe coating
- Reusable and safe for long-term use
- Suitable for all weather conditions
- Product range 114.3 – 508.0 (4.5" - 20")
- Length of the carrier: 1225 mm (48.2")
- Width of the carrier: 115 mm (4.53") Type 2: 130 mm (5.12")
- Maximum load capacity as indicated in the instruction

### Equipment

Pipe Carrier Premium consists of a range of Base-Carriers and a range of Mid-Carriers (Types 2-5). The Base-Carrier is placed at the bottom. After placing the first layer of pipes on the Base-Carrier, the Mid-Carrier is positioned on top of the first layer of pipes. After that another layer of pipes can be placed on the Mid Carrier and another Mid-Carrier can be placed on top of pipes to continue with the pipe loading process. The number of Carriers depends on the total weight of the pipes. If the Pipe Carrier Premium is used for transport, Anti-Skid mats have to be placed underneath the Base-Carrier and in the pipe spaces as shown on next side. Always use pipe spaces to stack pipes. The sides of the Pipe Carrier Premium must not be in contact with the pipe.



### Material specifications

PE-compound	colour black
Hardness	92° shore A
Frictional resistance factor (F.r.)	0.3
F.r. with Anti-Skid rubber	0.6
UV-stabilized	yes
Application temperature max.	45°C / 60°C (-45°F / 140°F)
Lifetime of approx.	15 years - no guarantee

## Pipe Carrier Premium 4 pipes

Types of Pipe Carrier Premium	Pipe diameter range (mm)	Pipe diameter range (inch)	Max. Load per Recess (kg)	Max. Load Base Carrier (kg)	Max. Load Mid Carrier (kg)
Pipe Carrier 6	Ø 114,3 - 194,2	Ø 4.50 - 7.65	1,436.0	8616	8616
Pipe Carrier 5	Ø 177,8 - 235,0	Ø 7.00 - 9.25	2,233.7	11169	11169
Pipe Carrier 4	Ø 219,1 - 296,3	Ø 8.63 - 11.67	2,750.0	11000	11000
Pipe Carrier 3	Ø 273,1 - 398,3	Ø 10.75 - 15.68	3,429.7	10289	10289
Pipe Carrier 2	Ø 355,6 - 508,0	Ø 14.00 - 20.00	5,050.1	10100	10100



### Anti-Skid

Weight of the Anti-Skid (200 mm x 8 mm) is approximately 1.4 kg/metre.

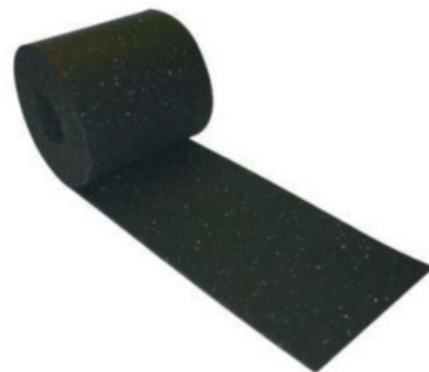

### Base and Mid Carrier

The Base-Carrier is recognisable from the flat surface at the bottom.

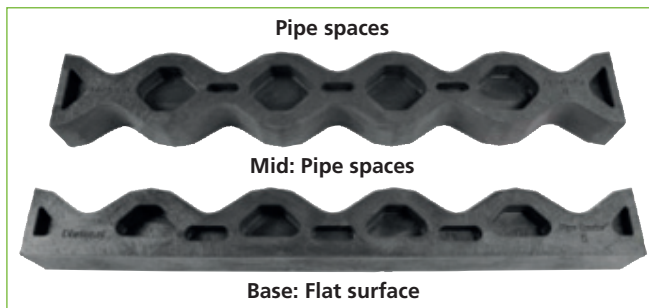

Type	Weight (kg)	Art.-No.
Pipe Carrier Premium 6 Base	11.2	59080
Pipe Carrier Premium 6 Mid	12	59081
Pipe Carrier Premium 5 Base	11.8	59082
Pipe Carrier Premium 5 Mid	11.5	59083
Pipe Carrier Premium 4 Base	11.2	59084
Pipe Carrier Premium 4 Mid	12	59085
Pipe Carrier Premium 3 Base	12.3	59086
Pipe Carrier Premium 3 Mid	13.9	59087
Pipe Carrier Premium 2 Base	15.6	59088
Pipe Carrier Premium 2 Mid	18	59089

### Application

The Base-Carrier is placed at the bottom. After placing the pipes on the Base-Carrier, the Mid-Carrier is positioned on top. The number of Carriers depends on the total weight of the pipes.

**Further information on installation, storage and configuration can be found at:**  
[www.4pipes.de/pipestorage](http://www.4pipes.de/pipestorage)



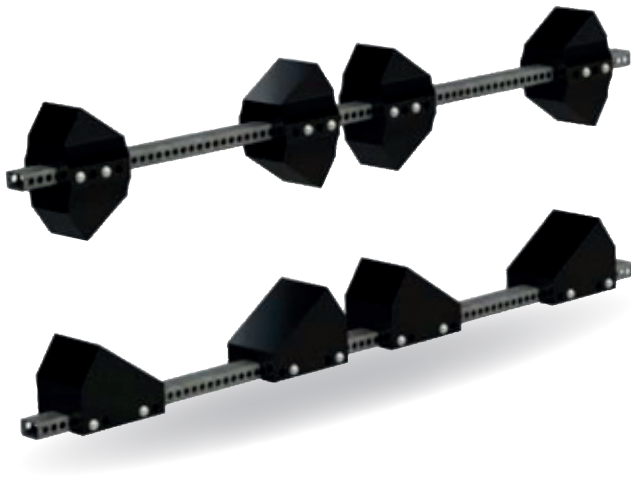

### General information

System88 is a **safe and flexible system to efficiently transport pipes by train or truck or store them**. It is a system that can easily be adjusted for different pipe diameters. The blocks are made out of a PE-compound and are safe for coated pipes. System88 is an engineered system based on extensive research and designed in accordance with EN1025 and VDI 2700 regulations. All static and dynamic calculations for pipe transport on truck and train have been evaluated and approved by TÜV Nord Germany. As the developers and manufacturers of the System88 program, Dhatec and 4 pipes give full technical support and advice.

### System88 offers the following advantages:

- Application range: 8" - 144" (219.1mm - 3657.6mm)
- 100% safe and reliable, also for coated pipes
- Highly durable and reusable
- Durable, safe for long-term use in all weather conditions
- Certified and approved by TÜV Nord Germany
- Easy application
- Reusable and therefore cost-effective
- Requires little storage space

### Additional information

- Maximum load on Block **A** = 3935kg (8675 lbs)
- Block **B C D** – 7875kg (17361 lbs)
- Block **K** = 3150kg (6944 lbs)
- Block **L** = 4725kg (10416 lbs)
- (Each pipe to be supported by a minimum of 4 blocks)
- Detailed instructions and settings are available
- Heat resistant blocks on request
- Anti-skid rubber available for higher frictional resistance
- Systems available to fix System88 on trailer or wagon
- For larger diameters, raising blocks are to be used
- Static and dynamic-calculations certified by TÜV NORD. Copy of certificate available on request

### Equipment

A minimum of 2 profiles per vehicle are required to support the pipes. Blocks will be secured on the profiles. Each bottom pipe is supported by a minimum of 4 blocks. The blocks are secured to the profile by locking pins with securing clips.

Material specifications	
Steel profile	Zinc plated steel S275J2, length: 2.70 m or 2.45 m (8.9ft or 8.0ft)
	Square tube: 80 mm x 50 mm x 5 mm (3.15" x 1.97" x 0.20") approx. 20 kg (44lbs)
	UV-stabilized
Locking pin	Zinc plated steel Grade 8.8 Ø 20 mm (0.79")
Blocks	PE-compound, colour: Black
	Frictional resistance factor (F.r): 0,3
	Frictional resistance factor (F.r): with Anti-skid rubber: 0.6
	Mounting holes in each block
Raising Block	UV-stabilized
	Zinc plated steel S355 540 mm x 201 mm x 191 mm (21.26" x 7.91" x 7.52")
Pipe size range	219.1 mm - 3657.6 mm (8" – 144")





# System88 4 pipes

Available sizes Basic Blocks		
Block	Diameter range	Weight
Type A	Ø 219.1 mm – 558.8 mm (8.63" - 22")	1.8 kg (3.97 lbs)
Type B	Ø 406.4 mm – 965.2 mm (16" - 38")	3.7 kg (8.16 lbs)
Type C	Ø 558.8 mm – 1422.4 mm (22" – 56")	7.5 kg (16.5 lbs)
Type D	Ø 1422.4 mm – 2.032 mm (56" - 80")	12.0 kg (26.5 lbs)
*Raising Block	Ø2032mm – 3657.6mm (80" – 144")	30 kg (66 lbs)

\*Addition for Block D: Raising Block  
Raising Block is available for Block D, it adds 140 mm height to this block, preventing the pipe from hitting the steel profile.

Available sizes Middle Blocks		
Block	Diameter range	Weight
Type K	Ø 219.1 mm – 558.8 mm (8.63" - 22")	2.8 kg (6.17 lbs)
Type L	Ø 406.4 mm – 1219.2 mm (16" - 48")	7.4 kg (16.3 lbs)



## Application

The base-section is placed on trailer or truck bed. After loading the bottom pipes, the mid-section is placed on top for the next layer of pipes. Pyramid stacking on the base-section is also possible.

**Further information on installation, storage and configuration can be found at:**  
[www.4pipes.de/pipestorage](http://www.4pipes.de/pipestorage)

<p><b>System88 steel profile</b> The square profile is available in the standard width of a - truck's trailer: 2450 mm <b>Art. No. 59000</b> - train's trailer: 2700 mm <b>Art. No. 59001</b> The weight of the profile is approx. 20 kg (truck) / 22kg (train)</p>	
<p><b>System88 Block A</b> This block will be placed on the bottom-profile. Diameter range: Ø 219.1 - 558.8 mm. Weight of the Block: approx. 1.8 kg. <b>Art. No. 59005</b></p>	
<p><b>System88 Block B for bottom-profile for Ø 406-945 mm- Art. No. 59007</b></p>	
<p><b>System88 Block C for bottom-profile for Ø 558-1422 mm- Art. No. 59009</b></p>	
<p><b>System88 Block D for bottom-profile for Ø 1422-2032 mm - Art. No. 59010</b></p>	
<p><b>System88 Block K</b> This block will be placed on a mid-profile. Diameter range: Ø 219.1 - 558.8 mm. Weight of the Block: approx. 2.8 kg. <b>Art. No. 59006</b></p>	
<p><b>System88 Block L</b> This block will be placed on a mid-profile. Diameter range: Ø 406.4 - 1219.2 mm Weight of the Block: approx. 7.4 kg. <b>Art. No. 59008</b></p>	
<p><b>Locking pin for blocks</b> This pin is used to secure the block on the rail. When the block and the rail align, a pin is placed through the aligned holes. Weight of the locking pin: approx. 0.6 kg <b>Art. No. 59015</b></p>	
<p><b>Securing clip for Locking pin</b> This is a safety attribute which will decrease the chances of the pin failing to secure the block on the rail. Weight of the clip: approx. 0.1 kg. <b>Art. No. 59016</b></p>	
<p><b>Anti-skid</b> <b>(NOT used when working on trains)</b> Anti-skid increases the friction between System88 and the load (0.3 → 0.6). Although it is not mandatory, 4pipes strongly recommends using it. Weight of the anti-skid: approx. 1.4 kg/m. <b>2.50 metre - Art. No. 59017</b> <b>2.75 metre - Art. No. 59018</b></p>	

## Conversion of Pressure Units

	bar	mbar	PA N/m <sup>2</sup>	kPa kN/m <sup>2</sup>	MPa MN/m <sup>2</sup>	atm	psi	mWS
bar	1	1'000	10 <sup>5</sup>	100	0.1	0.987	14.514	10.2
mbar	0.001	1	100	0.1	10 <sup>-4</sup>	0.987 · 10 <sup>-3</sup>	1.4514 · 10 <sup>-2</sup>	0.0102
PA N/m <sup>2</sup>	10 <sup>-5</sup>	0.01	1	0.001	10 <sup>-6</sup>	0.987 · 10 <sup>-5</sup>	1.4514 · 10 <sup>-4</sup>	1.02 · 10 <sup>-4</sup>
kPa kN/m <sup>2</sup>	0.01	10	1'000	1	0.001	9.87 · 10 <sup>-3</sup>	0.1451	0.102
MPa MN/m <sup>2</sup>	10	104	106	1'000	1	9.87	145.14	102
atm	1.013	1'013	1.013 · 10 <sup>5</sup>	101.3	0.1013	1	14.7	10.332
psi	0.0689	68.9	6.89 · 10 <sup>3</sup>	6.89	6.89 · 10 <sup>-3</sup>	6803 · 10 <sup>-2</sup>	1	0.703
mWS	0.0981	98.07	9.807	9.81	9.81 · 10 <sup>-3</sup>	0.0968	1.423	1

4 pipes accepts no liability for the accuracy of these figures.



# Terms of Sales

---

## § 1 Application

- (1) Our terms of sale apply only to companies.
- (2) Only our terms of sale apply, conflicting terms of the customer are not accepted.
- (3) Our terms of sale also apply to future deliveries to the customer.

## § 2 Price and payment

- (1) Only the price list valid on the day of delivery is applicable. Our prices are EXW (ex works), unless otherwise agreed. All costs for packing and transport are borne by the customer. We are allowed to pass on any increase for value-added tax, freight, duty, raw material, supplies and labor costs.
- (2) Our invoices are payable net within 30 days, for payment within 14 days we grant 2% cash discount. We charge interest of 8% above the relevant base interest rate for delayed payment, the right of assertion of further claims or damages remains unaffected. Checks are only considered as payment after the check has been cashed.
- (3) Counterclaims are only accepted if they are undisputed or legally established.

## § 3 Offer and acceptance

- (1) Our offers are subject to change, unless explicitly otherwise agreed.
- (2) Orders received are binding.
- (3) In case of online-orders the customer makes a binding offer by using the order button, with our order confirmation the contract becomes valid.

## § 4 Delivery

- (1) The given delivery time requires, that the customer fulfils all contractual duties in time, especially all technical details have to be clearly defined and all drawings require a qualified approval.
- (2) Place of delivery is our business location. The risk passes to the customer upon receipt by the carrier. In case the acceptance of the delivery is delayed, the risk passes to the customer when we are ready to deliver; in that case the customer bears the cost for storing and maintaining the goods.
- (3) Unless otherwise agreed, the times for delivery or performance are always approximated and refer to handing over the goods to the carrier.
- (4) Our obligation for delivery depends on receiving our own deliveries on time. Partial deliveries are allowed if the customer can use it. Our obligation is fulfilled, if and when the delivery is within generally admitted tolerances.

## § 5 Inability to pay our invoice

If and when the customer is late in payment by more than four weeks, we are allowed to rescind the contract or ask for securities in the amount of the outstanding receivables.

## § 6 Warranty

- (1) The customer shall assert claims due to defective goods, supplied by us, in writing without delay. If the defect of the goods was already predictable in the drawing, the customer can only assert claims if he informs us without delay in writing about the faulty drawing.
- (2) Our supply is correct, if it is within the relevant industry and quality standards and measurement limits.
- (3) It is the sole responsibility of the customer to check carefully the fitness of the goods for the intended use.
- (4) In case of defective goods, we are entitled to eliminate the defect or supply replacement. If the rework or the replacement delivery fails, the customer has the right of conversion or withdrawal of the contract, as far as the law provides for.
- (5) The description of our goods does not cause any guarantee, this applies likewise for all information on our website.
- (6) The statute of limitation for claims of defects is 12 months, except § 438 Abs. 2 Nr. 2 und § 634 a Abs. 1 BGB provide for longer periods.
- (7) No warranty is applicable, if the customer or a third party alters the goods without our approval.

## § 7 Reservation of title

- (1) We keep ownership of the goods until the complete payment has been received.
- (2) If and when the customer is late in payment, we are allowed to rescind the contract. We demand immediate information in case of intervention by third parties, any costs of third-party proceedings are borne by the customer.
- (3) The customer is allowed to sell the goods with or without further treatment; all claims which accrue from resale are assigned to us.
- (4) Any processing of the delivered goods is made on our behalf. In case our goods are processed with third-party material, we acquire shared ownership in the new product in relation of the used materials.

## § 8 Liability

- (1) Our liability for breach of contract in case of our own gross fault is limited to the compensation for the typically foreseeable damage.
- (2) We are liable for any culpable breach of main contractual obligations and culpable injury to life, body and health.
- (3) Any further liability is excluded; compulsory liability by law remains unaffected.
- (4) Services which are provided for free are not part of our contractual duties and therefore exempt from any liability.

## § 9 Law and jurisdiction

Our contracts are subject to German law, the commercial UN-law is not applicable. Place of jurisdiction is our place of business, we reserve the right to take action against the purchaser at his place of business.

Version 01/2019





4 pipes GmbH • Sigmundstraße 182 • 90431 Nürnberg/Germany  
Phone +49 (0)911 81006-0 • Fax +49 (0)911 81006-111  
info@4pipes.de • www.4pipes.de

